

ALDAS-Mini

Check for the latest edition and other language versions.



**Read carefully before use.
Keep for future reference.**

Safety Information ▶ p.11

Measurement Process ▶ p.16

Part Names and Functions ▶ p.18

Maintenance and Service ▶ p.115

Troubleshooting ▶ p.117

EN

Contents

Introduction.....	5	3.1	Launching the EA5700 ALDAS (PC Application)	41	1
Inspecting Package Contents.....	6	3.2	Creating a Measurement Project	42	2
Options (Sold Separately)	7	3.3	Connecting to the System Instruments	44	3
Symbols and Abbreviations	9	3.4	Setting the Measurement Method	46	4
Safety Information	11		Setting the measurement target (DUT)	46	5
Precautions for Use	13		Setting the measurement method	47	6
Measurement Process.....	16		Setting the EIS Mode measurement method	48	7
1 Overview	17		Setting the Logging Mode (Fixed Frequency) measurement method	50	8
1.1 Product Overview and Features.....	17		Setting the Logging Mode (Only DC Measurements) measurement method.....	52	9
1.2 Part Names and Functions.....	18		Configuring the Sense Module	54	10
Sense Module	18		Review measurement settings.....	55	11
Source Module	20	3.5	Main Application Window Overview .	56	
1.3 System Architecture	22	3.6	Measurement Project Files and Folders	57	
2 Preparing for Measurement	23	4 Making Measurements	59		
2.1 Inspecting the Products Before Use.	23	4.1	Starting Measurement.....	59	
2.2 Preparing the PC Application	24	4.2	Checking Conditions During Measurement	61	
Setting the PC's IP Address	24	4.3	Stopping Measurement	62	
Installing the PC application	26	4.4	Measuring continuously (When There Are Multiple Measurement Conditions)	63	
2.3 Connecting the Sense Cable (Voltage Input).....	30	5 Checking Impedance Measurement Results	65		
2.4 Connecting the Current Sensor (Current Input).....	31	5.1	Viewing Data Files.....	65	
2.5 Connecting the Source Cable	33	5.2	Changing the Graph's Configuration Settings.....	69	
2.6 Connecting LAN Cables	34	5.3	Manipulating Data Filters	70	
2.7 Connecting the Power Cords	35	6 I-V Graph Function	73		
2.8 Connecting to the Measurement Target	36	6.1	Displaying I-V Data	73	
2.9 Supplying Power to the System	39	6.2	Changing the I-V Graph Settings	74	
Turn on the system.....	39	6.3	Editing I-V Data	76	
Turn off the system.....	39				
2.10 Performing Zero Adjustment and Degaussing (DMAG)	40				
3 Configuring the PC Application	41				
USB dongle key	41				

Editing Cell Information	76
Editing the I-V information	77
6.4 Exporting the I-V Data to a File	79

7 PC application functions 81

7.1 Graph Common Operation	81
Setting for Displaying or Hiding the Measurement Data Graph	81
Viewing Graphs	82
Displaying the Data Details on Graphs.....	83
Setting the Graph Color and Marker Shape	84
7.2 Manipulating Measurement Conditions Files.....	85
Adding, deleting, sorting, and previewing the measurement conditions ..	85
Change the existing measurement conditions	86
Adding the existing measurement conditions	87
Changing the name of measurement conditions	88
7.3 Manipulating Data Files.....	89
Loading a data file	89
Changing a data file's name	91
Removing a data file from the list	92
Exporting data files	94
7.4 Checking the System Connection Status and Reconnection	96
7.5 Manipulating Project Files	97

8 Ending Measurement 99

8.1 Exiting the PC application	99
8.2 Turn off the system instruments	99
8.3 Disconnect the cables and current sensor from the measurement target	99

9 Specifications 101

9.1 EA5701 ALDAS-mini	101
General specifications.....	101
Functional specifications	102

9.2 EA5301 Sense Module	105
General specifications.....	105
Input, output, measurement specifications.....	106
Functional specifications	108
Interface specifications.....	109
9.3 EA5501 Source Module	110
General specifications.....	110
Input, output, measurement specifications.....	110
System Specifications	111
9.4 L1100 Sense Cable	113
General specifications.....	113
9.5 L1150 Source Cable	113
General specifications.....	113

10 Maintenance and Service 115

10.1 Repairs, Inspections, and Cleaning	115
Calibration	115
Replaceable parts and service life.....	116
Cleaning	116
10.2 Troubleshooting.....	117
10.3 Error Messages	118
10.4 Disposal of the Products	120

11 Appendix 121

Impedance measurement during DC operation	121
Methods for Stabilizing Measurement	124

Index 125

Warranty Certificate

Introduction

Thank you for choosing the Hioki Active Line Device Analysis System (ALDAS).

To ensure your ability to get the most out of this system over the long term, please read this manual carefully and keep it available for future reference.

Information on download site

For details on the product application, the update file for the instrument, and the instruction manual, please check Hioki's website:

<https://cloud.gennect.net/dl>



Website for use within China.

<https://gennect.cn/dl>



Request for product user registration

Please register this product so that you can receive important information regarding the product.

<https://www.hioki.com/global/support/myhioki/registration/>



The following documentation is available for reference according to your application:

Names of the instruction manuals	Contents	Form of supply
Instruction Manual (this manual)	Product overview, operating instructions, function descriptions, and specifications for this system.	Hard copy
Operating Precautions	This document contains information for the safe use of this system. Please read Operating Precautions carefully, before using this system.	Hard copy

Target audience

This manual has been written for use by individuals who use the product or provide information about how to use the product.

In explaining how to use the product, it assumes electrical knowledge (equivalent of the knowledge possessed by a graduate of an electrical program at a technical high school).



Trademarks

- Microsoft Edge and Windows are trademarks of the Microsoft group of companies.
- Adobe and Adobe Acrobat Reader are either trademarks or registered trademarks of Adobe in the United States and other countries.
- Intel is a trademark of Intel Corporation or its subsidiaries in the United States and/or other countries.

Inspecting Package Contents

Upon receiving the products, inspect them for any damage or anomalies. If you discover any damage or find that the product does not perform as indicated in the specifications, please contact your authorized Hioki distributor or reseller.

Confirm the package contents.

Product name	Accessories
EA5301 Sense Module 	<ul style="list-style-type: none"> • Power cord • Operating Precautions (0990A905) • Download Guide
EA5501 Source Module 	<ul style="list-style-type: none"> • Power cord (for main power supply) • Power cord for connecting devices (0.9 m) ×2 (For Sense-to-Source module and Products for current measurement) • LAN cable (for connecting PC and Source Module, 3 m) • LAN cable (for connecting Sense Module and Source Module, 1 m) • Instruction Manual • Operating Precautions (0990A905)
EA5701 ALDAS-Mini (PC application)  The latest version of the firmware is available for download from Hioki's website.	<ul style="list-style-type: none"> • Z4006 USB Drive (PC application installer, Instruction Manual*¹) • USB dongle key (license key) <p>*1. Please visit Hioki's website to check for versions in other languages.</p>

EA5301 Sense Module model number

The branch part of the model number indicates the number of input channels.

Model number (order code)	Number of channels
EA5301-01	1 channel
EA5301-02	2 channels
EA5301-03	3 channels
EA5301-04	4 channels
EA5301-05	5 channels
EA5301-06	6 channels
EA5301-07	7 channels
EA5301-08	8 channels

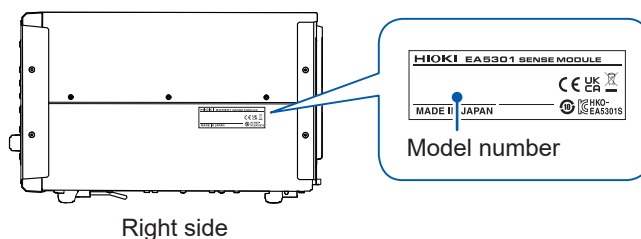

Options (Sold Separately)

The optional equipment listed below is available for the system. To purchase any optional equipment, please contact your authorized Hioki distributor or reseller. Please note that optional equipment offerings are subject to change without advance notice. For the latest information, check Hioki's website.

Cable for signal superposition



L1150	Source Cable (Maximum input current: 40 A AC/DC, continuous, Cable length: Approx. 2.0 m, tip: Alligator clips)	
-------	---	---

Cable for voltage measurement

L1100	Sense Cable (Maximum input voltage: 60 V DC, Cable length: Approx. 2.2 m, Banana plug to banana plug, Alligator clips included)	
-------	---	---

Products for current measurement

For details, refer to the instruction manual that came with the current sensor.

Product name	Model number	Rated current rms	Frequency characteristics (Recommended impedance measurement frequency range)	Reference accuracy (Amplitude) \pm (% of reading + % of full scale)	Core diameter
AC/DC Current Probe (High accuracy clamp) 	CT6841A	20 A	DC to 2 MHz	$\pm 0.2\%$ $\pm 0.01\%$	$\varnothing 20$ mm
	CT6843A	200 A	DC to 700 kHz (Up to 10 kHz)		
	CT6844A	500 A	DC to 500 kHz (Up to 10 kHz)		
	CT6845A	500 A	DC to 200 kHz (Up to 10 kHz)		
	CT6846A	1000 A	DC to 100 kHz (Up to 10 kHz)		$\varnothing 50$ mm
AC/DC Current Sensor (High accuracy pass-through) 	CT6872	50 A	DC to 10 MHz	$\pm 0.03\%$ $\pm 0.007\%$	$\varnothing 24$ mm
	CT6873	200 A			
	CT6875A	500 A	DC to 2 MHz	$\pm 0.04\%$ $\pm 0.008\%$	$\varnothing 36$ mm
	CT6876A	1000 A	DC to 1.5 MHz		
	CT6877A	2000 A	DC to 1 MHz		$\varnothing 80$ mm

Options (Sold Separately)







Product name	Model number	Rated current rms	Frequency characteristics (Recommended impedance measurement frequency range)	Reference accuracy (Amplitude) ± (% of reading + % of full scale)	Core diameter
AC/DC Current Sensor (Ultra-high accuracy pass-through) 	CT6904A	500 A	DC to 4 MHz	±0.2% ±0.007%	ø32 mm

Product name	Model number	Remarks
Sensor Unit 	CT9557	The CT9557 adds current waveforms measured by multiple sensors and outputs a single signal. Use it when measuring multi-cable circuits. The CT9904 connection cable (optional) is required to connect to the EA5301 Sense Module.







Symbols and Abbreviations

Safety



This manual classifies the seriousness of risks and hazard levels as described below.

 DANGER	Indicates an imminently hazardous situation that, if not avoided, will result in death or serious injury.
 WARNING	Indicates a potentially hazardous situation that, if not avoided, could result in death or serious injury.
 CAUTION	Indicates a potentially hazardous situation that, if not avoided, could result in minor or moderate injury or potential risks of damage to the supported product (or to other property).
IMPORTANT	Indicates information or content particularly important from the standpoint of operating or maintaining the product.
	Indicates a high-voltage hazard. Failure to verify safety or improper handling of the product will result in an electric shock, a burn, or injury, potentially leading to death.
	Indicates a prohibited action.
	Indicates the action which must be performed.

Symbols on the product

	Indicates the presence of a potential hazard. For more information about locations where this symbol appears on products' components, see "Precautions for Use" (p. 13) and warning messages listed at the beginning of operating instructions. In addition, see the accompanying document entitled "Operating Precautions" and "Current Sensor".
	Indicates the on position of the power switch.
	Indicates the off position of the power switch.
	Indicates the push-button switch that can turn on and off the product.
	Indicates the grounding terminal.
	Indicates that the product can be used to measure alternating current (AC) voltage/current or can be powered by utility AC power.

Symbols for various standards

	Indicates that the product is subject to the Directive on Waste Electrical and Electronic Equipment (WEEE) in EU member nations. Dispose of the product in accordance with local regulations.
	Indicates that the product complies with standards imposed by EU directives.
	Indicates that the product complies with Korean regulations. Declarer: HIOKI KOREA CO., LTD. http://www.rra.go.kr/selform/HKO-EA5301S http://www.rra.go.kr/selform/HKO-EA5501

Others

*	Indicates that additional information is described below.
(p.)	Indicates the page number to reference.
START (Bold)	The letters and key names on the screen are highlighted in bold.
[]	The names of user interface elements on the screen are enclosed in brackets ([]).
Windows	Unless otherwise noted, the term Windows is generically used to refer to Windows 10 and Windows 11.

Accuracy labeling

The accuracy of the measuring instrument is expressed by defining limit values for errors as a percentage of the reading and a percentage of the range.

Reading (display value)	Indicates the value displayed on the measuring instrument. Limit values for reading errors are expressed as a percentage of the reading (% of reading or % rdg).
Range	Indicates the measurement range of the measuring instrument. Limit values for range errors are expressed as a percentage of the range (% of range or % rng).

Safety Information

The products included in this system has been designed in accordance with the international standard IEC 61010 and has undergone rigorous safety testing prior to shipment. However, using the system in a way not specified in this manual may compromise its safety features.

Carefully read the following safety notes before use.

DANGER



- **Familiarize yourself with the contents of this manual before use.**

Failure to follow this guidance will result in misuse, leading to serious bodily injury or damage to the products.

WARNING



- **If you have not previously used electrical measuring instruments, ensure adequate supervision by a technician with experience in electrical measurement.**

Failure to follow this guidance could result in electric shock.

It could also cause serious incidents, such as heat generation, fire, or arc flash due to a short-circuit.

Measurement categories

IEC 61010 defines measurement categories to ensure the safe use of measuring instruments. Test and measurement circuits are classified into three categories based on the type of mains they are intended to be connected to. A measuring instrument that does not have a measurement category cannot be used to measure a main power supply circuit.

⚠ DANGER

- Do not use a measuring instrument to measure a main power supply circuit whose category exceeds the instrument's rated measurement category.



- Do not use a measuring instrument that does not have a rated measurement category to measure a main power supply circuit.

Doing so may result in serious bodily injury or damage to the instrument or other equipment.

No measurement category (O)	Applicable to the measurement of other circuits that are not directly connected to the main power supply. EXAMPLE: Measurement on the secondary-side equipment from the socket outlet of fixed installation through a transformer, etc.
Measurement category II (CAT II)	Applicable to test and measuring circuits connected directly to utilization points (socket outlets and similar points) of a low-voltage mains installation. EXAMPLE: Measurements on household appliances, portable tools, and similar equipment, and on the consumer side only of socket outlets in the fixed installation.
Measurement category III (CAT III)	Applicable to test and measuring circuits connected to the distribution part of a building's low-voltage mains installation. EXAMPLE: Measurements on distribution boards (including secondary meters), photovoltaic panels, circuit breakers, wiring, including cables, bus-bars, junction boxes, switches, and socket outlets in a fixed installation, as well as equipment for industrial use and some other equipment such as stationary motors with permanent connection to the fixed installation.
Measurement category IV (CAT IV)	Applicable to test and measuring circuits connected at the source of the a building's low-voltage mains installation. EXAMPLE: Measurements on devices installed before the main fuse or circuit breaker in the building installation.

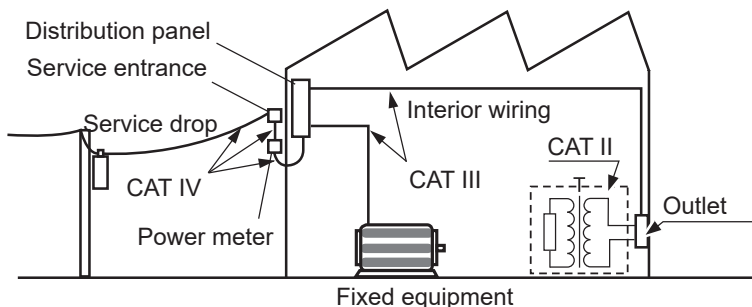

Precautions for Use

Be sure to follow the precautions listed below in order to use the system safely and in a manner that allows it to function effectively.

Use of the system should conform not only to its specifications, but also to the specifications of all accessories, options, and other equipment in use.

Installing the system

WARNING

Do not install the system in the following locations:

- Locations with direct sunlight exposure or high temperatures
- Locations where corrosive or explosive gases are generated
- Locations with powerful electromagnetic radiation exposure or electrostatic charges
- Close to inductive heating devices (high-frequency inductive heating devices, IH cooktops, etc.)
- Places where there is a lot of mechanical vibration
- Locations exposed to water, oil, chemicals, or solvents
- Places with high humidity or condensation
- Locations with an excessive amount of dust
- Locations with an unstable or inclined position



Doing so could damage the system or cause it to malfunction, resulting in bodily injury.

- **Place the Source Module, leaving enough space around it to facilitate unplugging the power cord.**



If there is not enough space left around, the power cannot be shut off immediately in an emergency.

Failure to follow this guidance could result in bodily injury, fire, or damage to the device.

CAUTION



- **When placing the Sense Module on top of the Source Module, take measures to prevent them from tipping over or falling, such as securing them with Velcro belts.**

If not secured properly, the Sense Module could tip over or fall, causing damage.

Precautions for Use

- Leave the specified distance of space from the modules to prevent their temperature from rising.
Sense Module: At least 30 mm (all surfaces except bottom) and at least 15 mm (height of support legs) above surface on which installed
Source Module: At least 100 mm (front), at least 600 mm (rear)
- Place with its bottom side facing downward.
- Do not block vent openings.

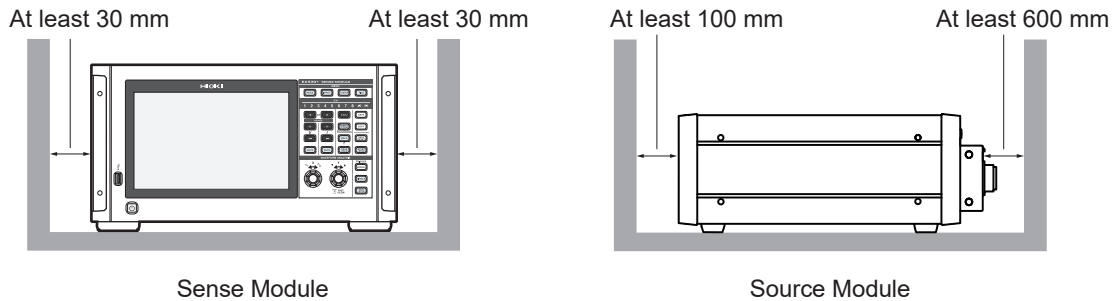

The modules are classified as a Class A device under the EN 61326 standard. Use of them in a residential setting such as a neighborhood could interfere with reception of radio and television broadcasts. If this occurs, take appropriate steps to counteract the issue.

Cautions for measurement

DANGER



- **Do not use the system to measure circuits that exceed the ratings or specifications of the system.**
Doing so could cause damage to the system or overheating, resulting in serious bodily injury.

WARNING



- **Do not measure a voltage of 60 V DC or more.**
- **Do not measure AC voltages.**
Failure to follow this guidance could damage the system, resulting in bodily injury.
- **Do not touch the wires being measured.**
The wires being measured could become hot, possibly resulting in burns.
- **When connecting measurement cables, exercise care not to mistake voltage input terminals for current input terminals.**
Mistaking these cables could damage the system or cause the circuit under measurement to short-circuit, resulting in bodily injury.

Cautions for transporting the products

CAUTION



- Do not subject the products to vibration or mechanical shock while transporting or handling them.

- Do not drop the products.

Failure to follow this guidance could damage the products.



- Work with at least one other person to shift the Source Module using the handles on the left and right sides.

Source Module weight: Approx. 27.0 kg

- Follow your company's safety guidelines, such as using anti-slip gloves and safety boots.

Failure to follow this guidance could cause bodily injury.

Shipping precautions

- When shipping the system, use the original boxes and packaging materials in which they were delivered. However, do not use the original boxes and packaging materials if they are damaged. If the original boxes and packaging materials cannot be used, contact your Hioki distributor. You will be sent suitable boxes and packaging materials.
- When packing the system, disconnect test leads and a USB flash drive.
- When transporting the system, exercise care to avoid dropping them or otherwise subjecting them to rough handling.

Warranty

- Please note that in the event the system is embedded in another system or sold to another owner, Hioki is not liable for any direct or indirect damage sustained by the end-user.
- The L1100 Sense Cable and L1150 Source Cable are not covered by the warranty.

Measurement Process

The basic measurement procedure is as follows:

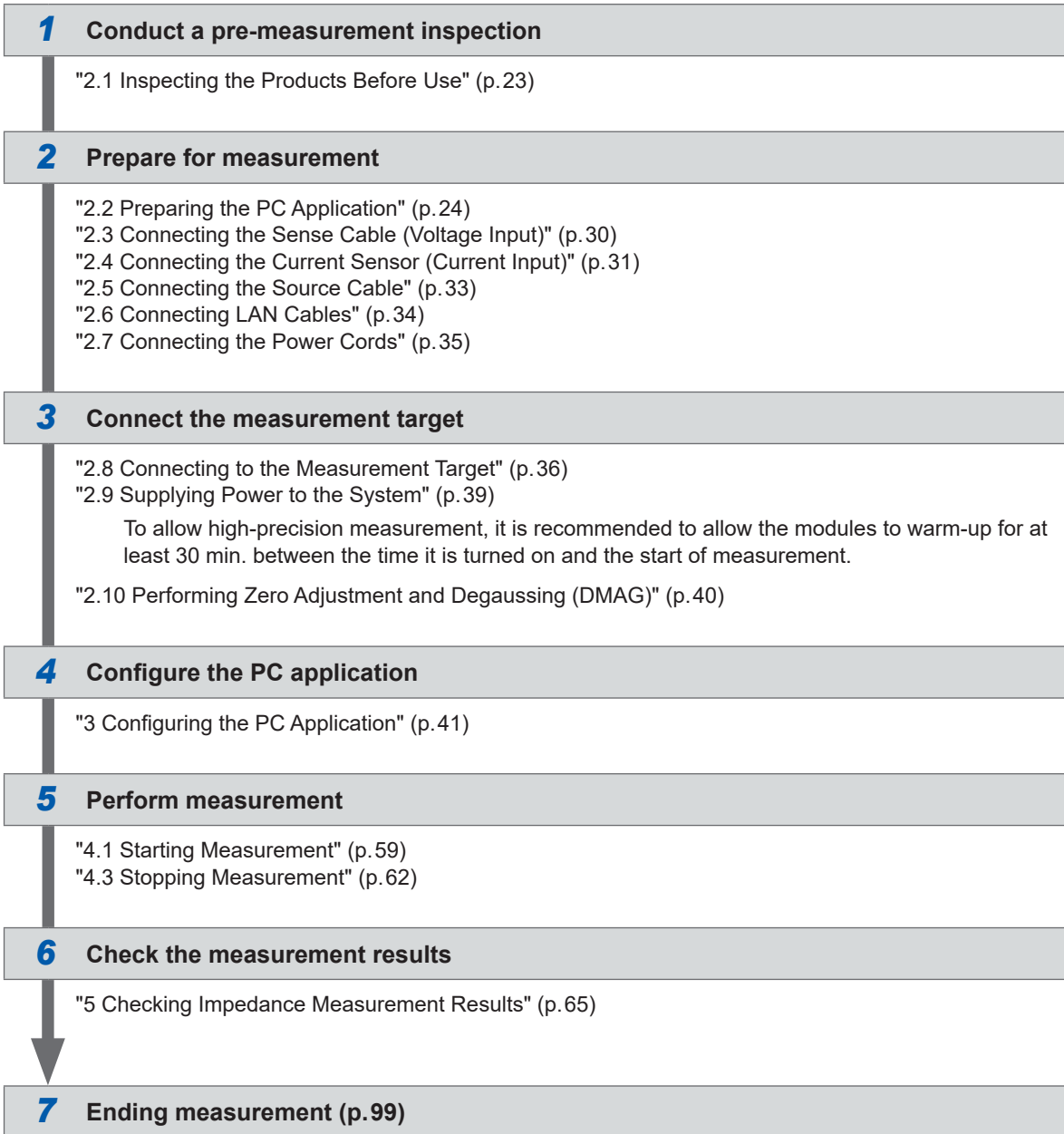

1.1 Product Overview and Features

This product is an Active Line Device Analysis System (ALDAS) that can conduct electrochemical impedance spectroscopy (EIS) measurements and plot I-V graph characteristics simultaneously for electrolysis cell (EC) or fuel cell (FC) during its operation.

- **Impedance measurement with excellent reproducibility**

The system is capable of delivering accurate and consistent impedance measurements, even in environments with a lot of electrical noise, such as those from electrolysis devices in operation.

- **Simultaneous multichannel measurement**

The Sense Module can measure up to eight channels simultaneously.

- **Cole-Cole plots (Nyquist plots)**

The system can perform impedance measurement and generating Cole-Cole plots (Nyquist plots) based on user-defined frequency lists ranging from 0.01 Hz to 100 kHz.

- **Extended duration impedance measurement**

The system can measure impedance at a user-defined frequency and fixed interval, logging readings up to 180 days.

- **Parameter comparisons on the graph**

The measured data can be compared on a graph instantly to verify the measurement parameters of the experiment.

- **I-V graph**

The system plots the I-V graphs based on the DC current and DC voltage values acquired simultaneously with impedance measurements.

1.2 Part Names and Functions

Sense Module

Front side

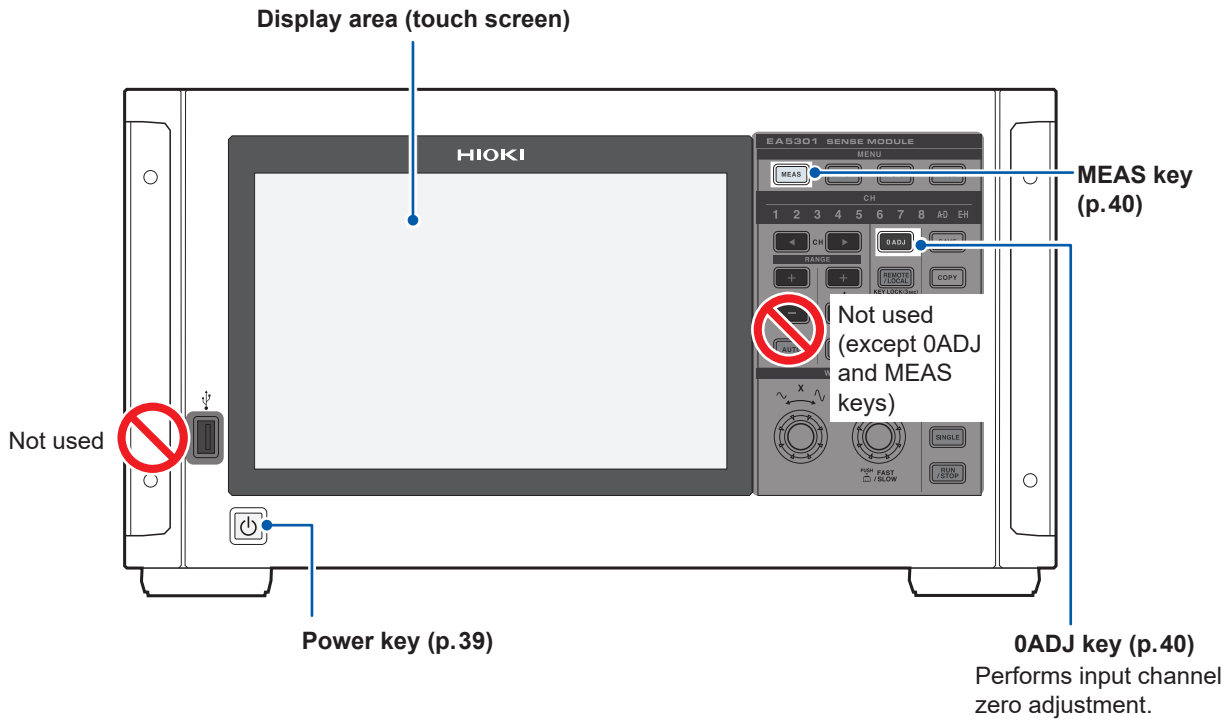

Handling the touch screen

CAUTION

- Do not press too hard on the touch screen.
 - Do not use hard or sharp objects to operate the touch screen.
- Failure to follow this guidance could damage the module.

Rear side

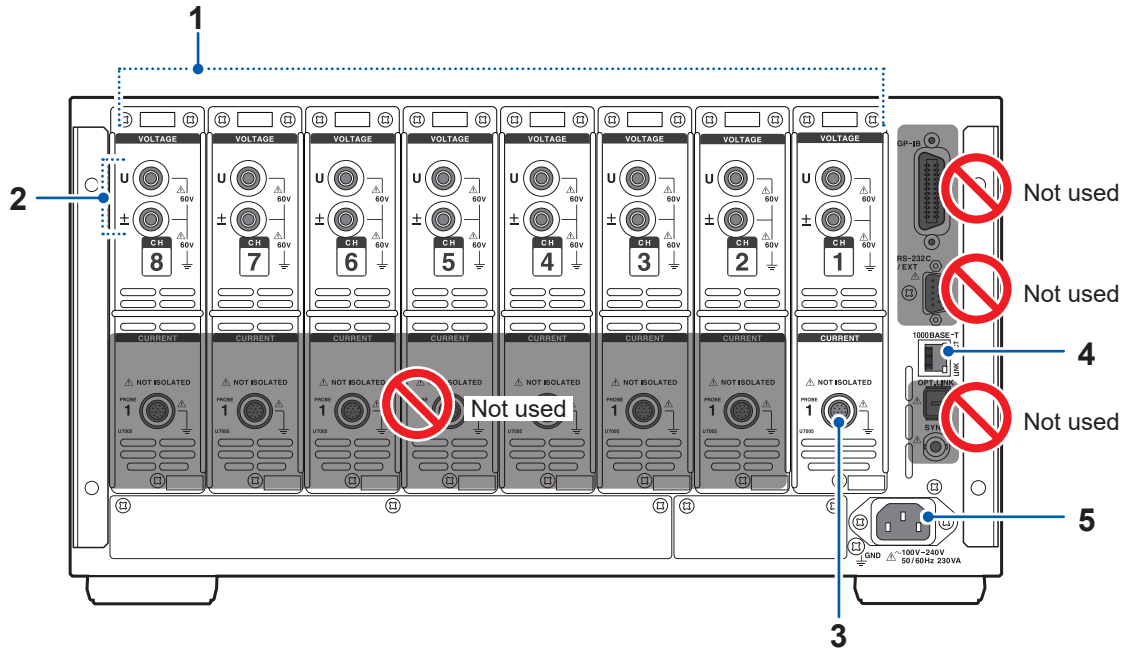

1	Input channels	The Sense Module accepts up to eight voltage input channels. (Specify the number of input channels when ordering.)	p. 6
2	Voltage input terminals	Connect the L1100 Sense Cable.	p. 31
3	Probe 1 terminals (For current sensors)	Connect Hioki's current sensors. The Sense Module automatically recognizes current sensors. It also supplies power to the current sensors.	p. 33
4	RJ-45 connector (Gigabit Ethernet)	Connect the Sense Module and Source Module with a LAN cable.	p. 34
5	Power supply inlet	Connect the supplied power cord for connecting devices and plug it to the Source Module's power outlet.	p. 35

Right side

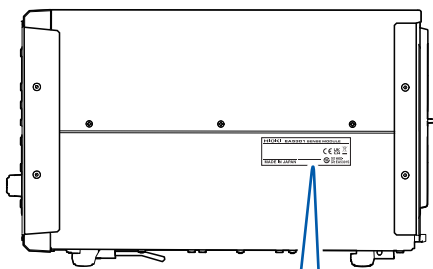

Left side

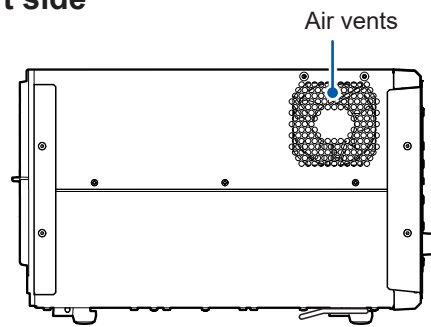

Label

Model number Serial number*

MAC address

*: Serial number
Please check Hioki's website for the latest information.
Do not remove this sticker as the number is important.

Source Module

Front side

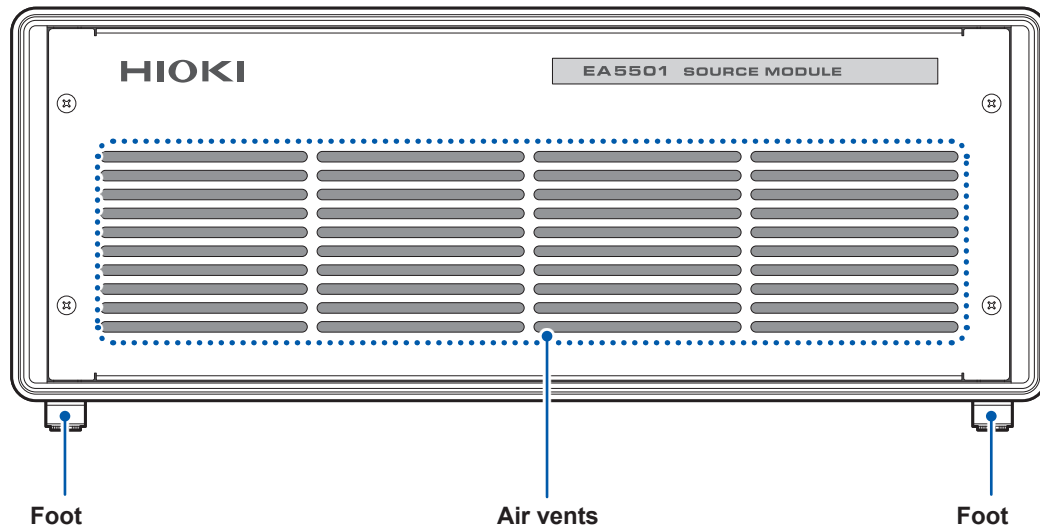

Rear side

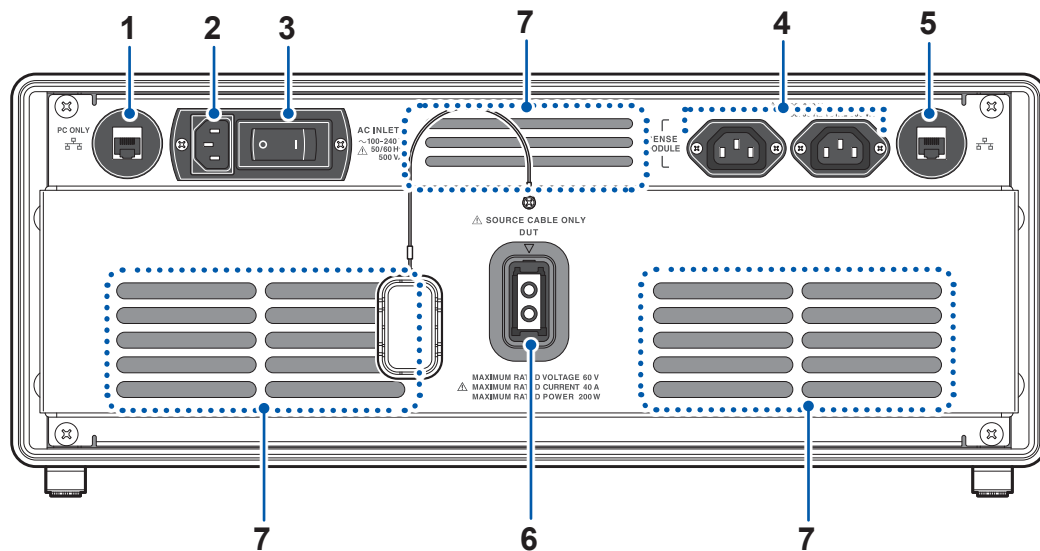

1	RJ-45 connector	Connect the Source Module and the computer with a LAN cable.	p.34
2	Power supply inlet	Connect the included power cord to the power supply.	p.35
3	Main breaker	Turns the entire system's main power supply on and off.	p.39
4	Power outlets	Plug in the Sense Module power cord to one of the power outlets. If necessary, you can connect the optional CT9557 to the second power outlet.	p.35
5	RJ-45 connector	Connect the Sense Module and Source Module with a LAN cable.	p.34
6	Signal superposition terminal	Connect the L1150 Source Cable.	p.33
7	Air vents	These ventilation holes prevent the internal parts from overheating. Do not block the air vents or insert any foreign.	—

Right side

Left side

Handles (recessed side handle on both sides)

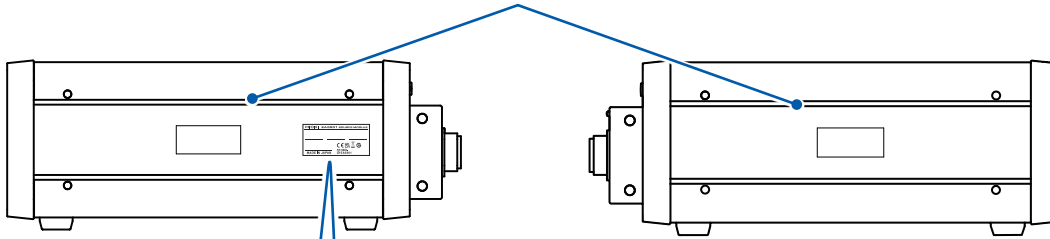

Label

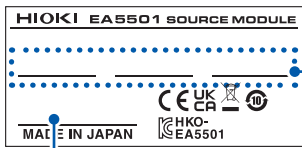

*: Serial number

Please check Hioki's website for the latest information.
Do not remove this sticker as the number is important.

Serial number*

MAC address

1.3 System Architecture

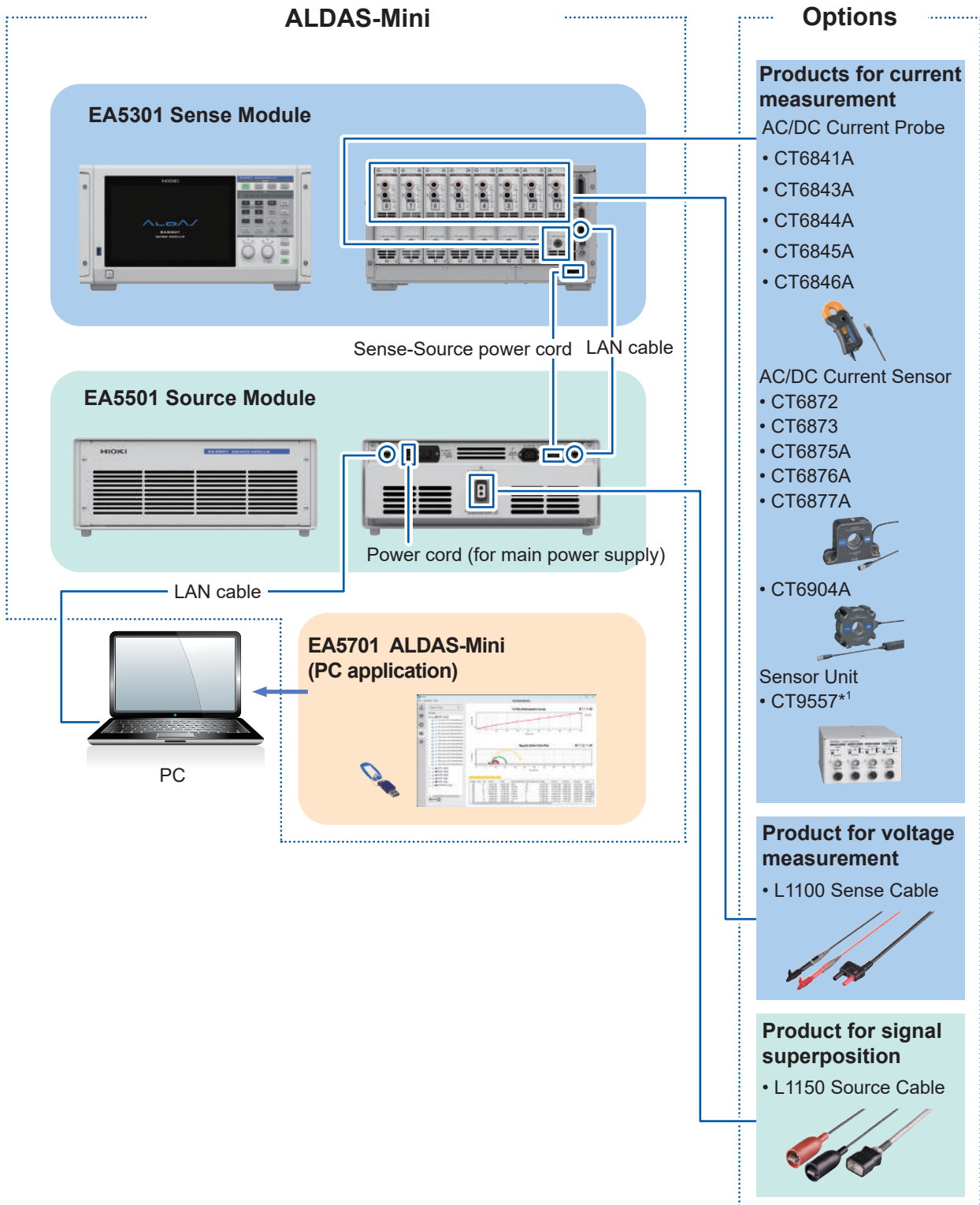

*1. The CT9904 connection cable (optional) is required to connect to the EA5301 Sense Module.

2

Preparing for Measurement

2.1 Inspecting the Products Before Use

Before starting measurement, inspect the system including the modules, accessories, and optional equipment.

DANGER



■ **Inspect the system and verify proper operation before use.**

Use of the system while it is malfunctioning could result in serious bodily injury. If you find any damage, contact your authorized Hioki distributor or reseller.

2

Inspecting accessories and optional equipment

Make sure that . . .	Action
Insulation of the power cords, Sense Cable, and Source Cable are not damaged. No metal is exposed.	Do not use damaged products with the system to avoid electric shock or short circuits. The system cannot perform measurements in this state. Contact your authorized Hioki distributor or reseller.
The current sensor's clamps are not cracked or damaged.	

Inspecting the system

Make sure that . . .	Action
The products are not damaged.	If damage is found, request repair.
The Sense Module displays [EA5301 SENSE MODULE] when turned on.	If [EA5301 SENSE MODULE] is not displayed, there could be damage to the power cord or a product malfunction. Please contact your authorized Hioki distributor or reseller.

2.2 Preparing the PC Application

For more information about system requirements, please see “(2) PC application operating environment” (p.101)

Setting the PC's IP Address

- 1 Press the Windows key and the R key at the same time.
The [Run] dialog box will be displayed.

- 2 Enter [ncpa.cpl] in the [Open] box and click [OK].

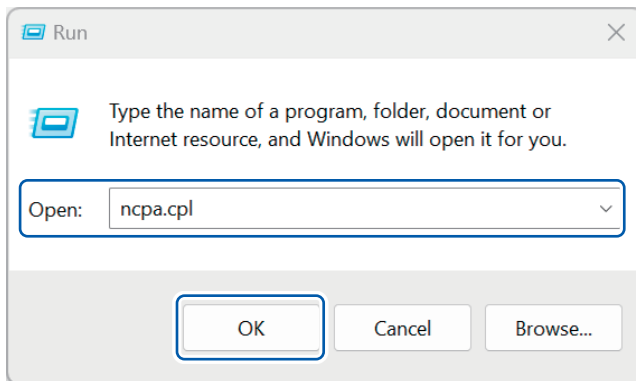

- 3 From the [Network Connections] window, double-click the selected Ethernet port for connecting the PC application with the system.

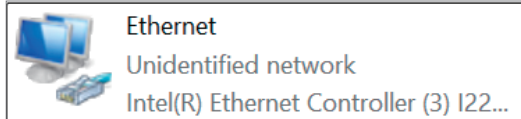

The [Ethernet Properties] dialog box will appear.

- 4 Select [Internet Protocol Version 4(TCP/IPv4)] and click [Properties].

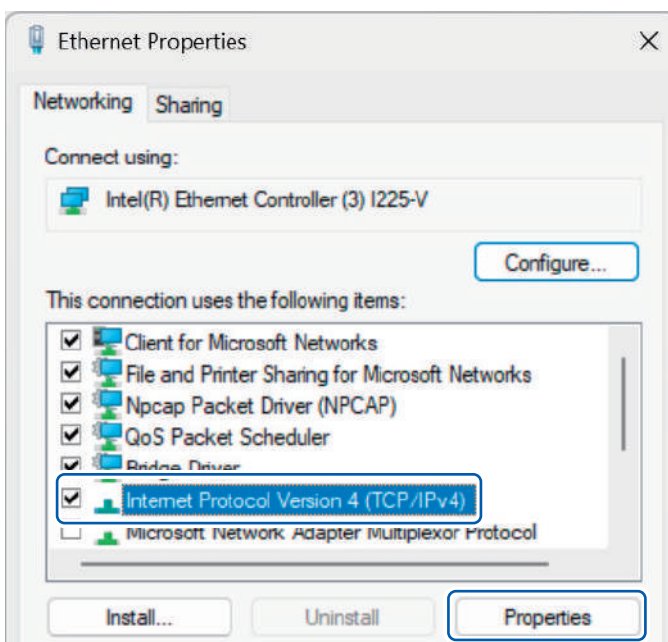

5 Set the [IP address] to 192.168.200.200.

The recommended setting range is from 192.168.200.5 to 192.168.200.255.

The following IP addresses cannot be used as they are reserved for the system's operation:

192.168.200.1 to 192.168.200.4

6 Set the [Subnet mask] setting to 255.255.0.0.**7** Leave the [Default gateway] setting blank.**8** Click [OK].

Internet Protocol Version 4 (TCP/IPv4) Properties

General

You can get IP settings assigned automatically if your network supports this capability. Otherwise, you need to ask your network administrator for the appropriate IP settings.

Obtain an IP address automatically

Use the following IP address:

5 IP address: 192 . 168 . 200 . 200

6 Subnet mask: 255 . 255 . 0 . 0

7 Default gateway: . . .

Obtain DNS server address automatically

Use the following DNS server addresses:

Preferred DNS server: . . .

Alternative DNS server: . . .

Validate settings upon exit

Advanced...

8 OK Cancel

Installing the PC application

Procedures

- 1** Log in to the PC using an administrator account.
- 2** Exit all running applications on PC.
- 3** Insert the USB drive with EA5700 application software into the PC's USB port.
- 4** Double-click the installer `[setup_EA5700 ALDAS_V(version number).exe]`.

When the installation mode selection screen appears:

Select **[Install for all users]**.

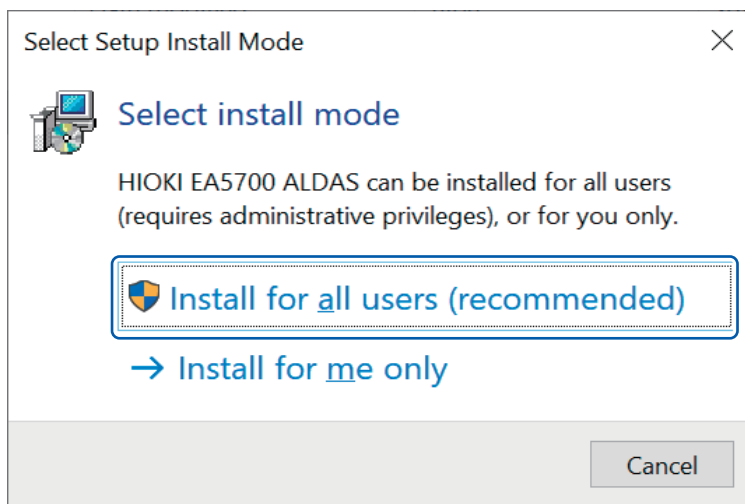

- 5** Select a language and click **[OK]**.

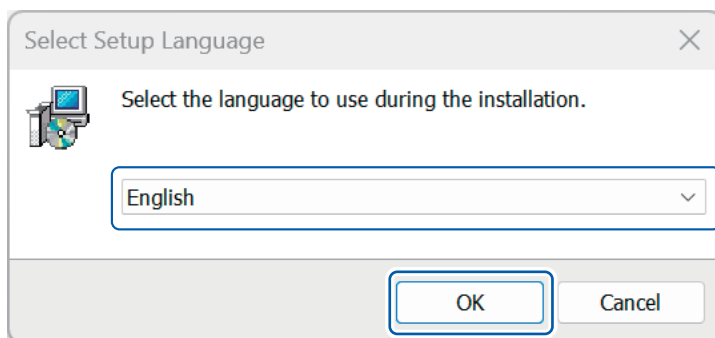

The **[Welcome to the HIOKI EA5700 ALDAS]** dialog box will be displayed.

6 Click [Next].

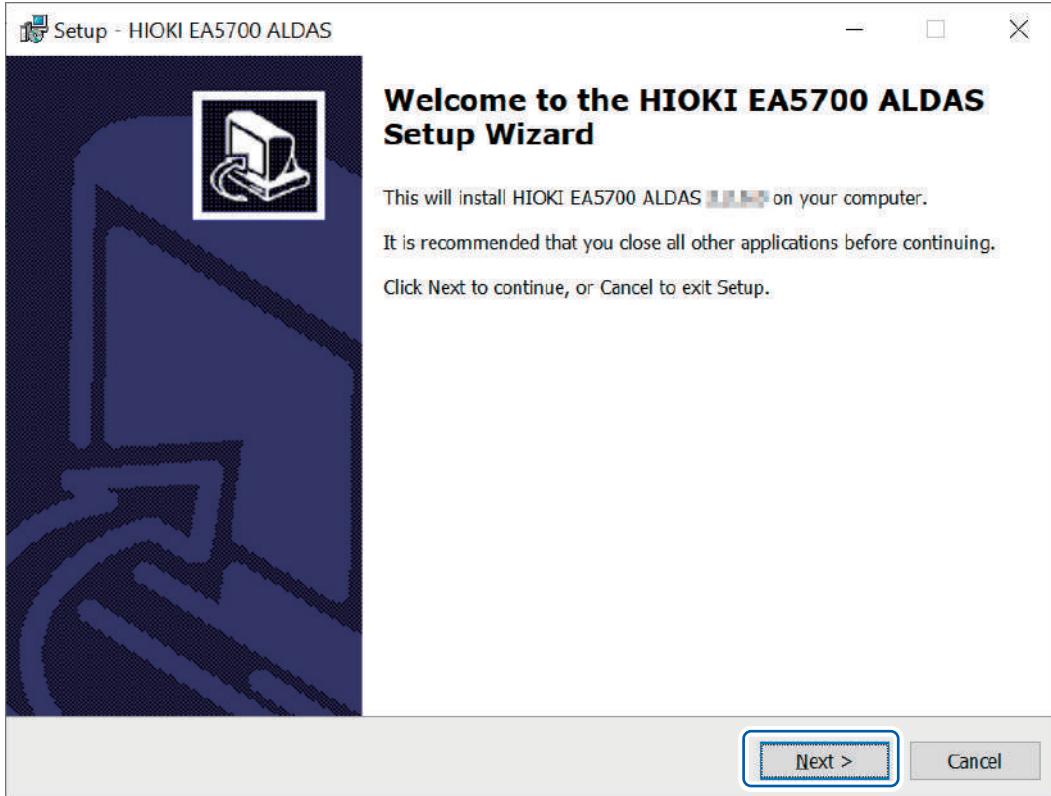

The [License Agreement] dialog box will be displayed.

7 Read the [User's License Agreement] and select the [I accept the agreement] option button. Click [Next].

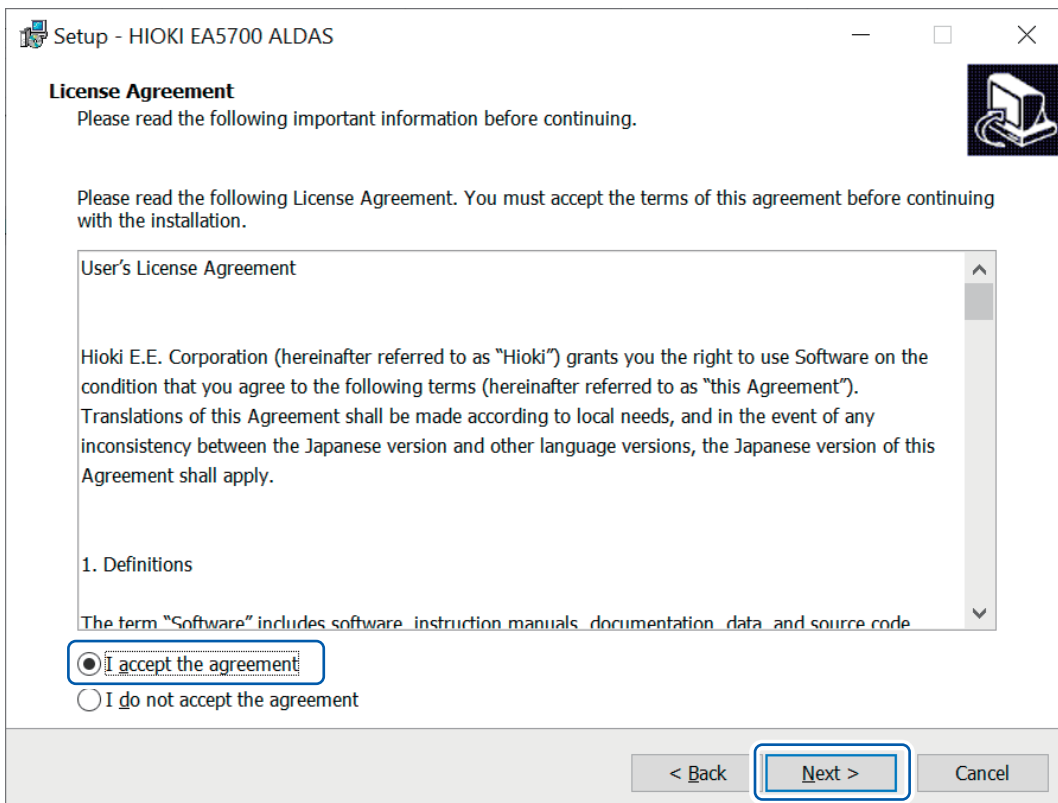

8 Confirm that the **[Create a desktop shortcut]** checkbox is selected and click **[Next]**.

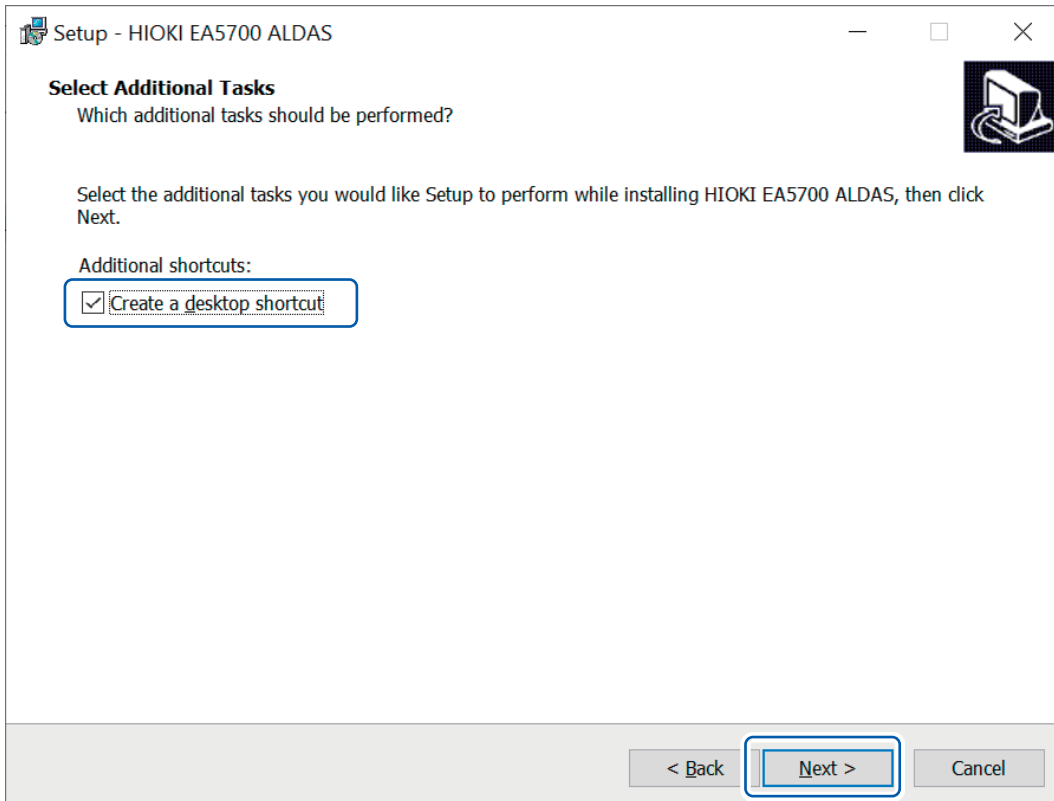

9 Review the information on the dialog box and click **[Install]**.

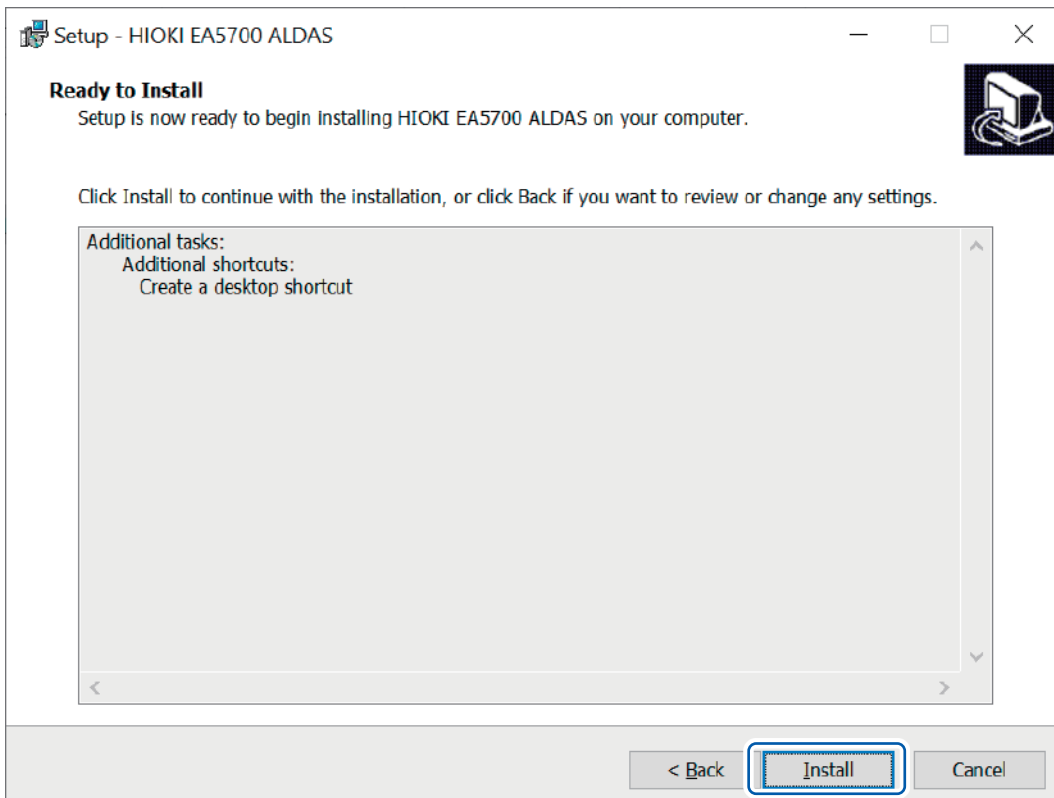

10 Once the installation has completed, click **[Finish]**.

If the **[Launch HIOKI EA5700 ALDAS]** checkbox is selected, the PC application will start.

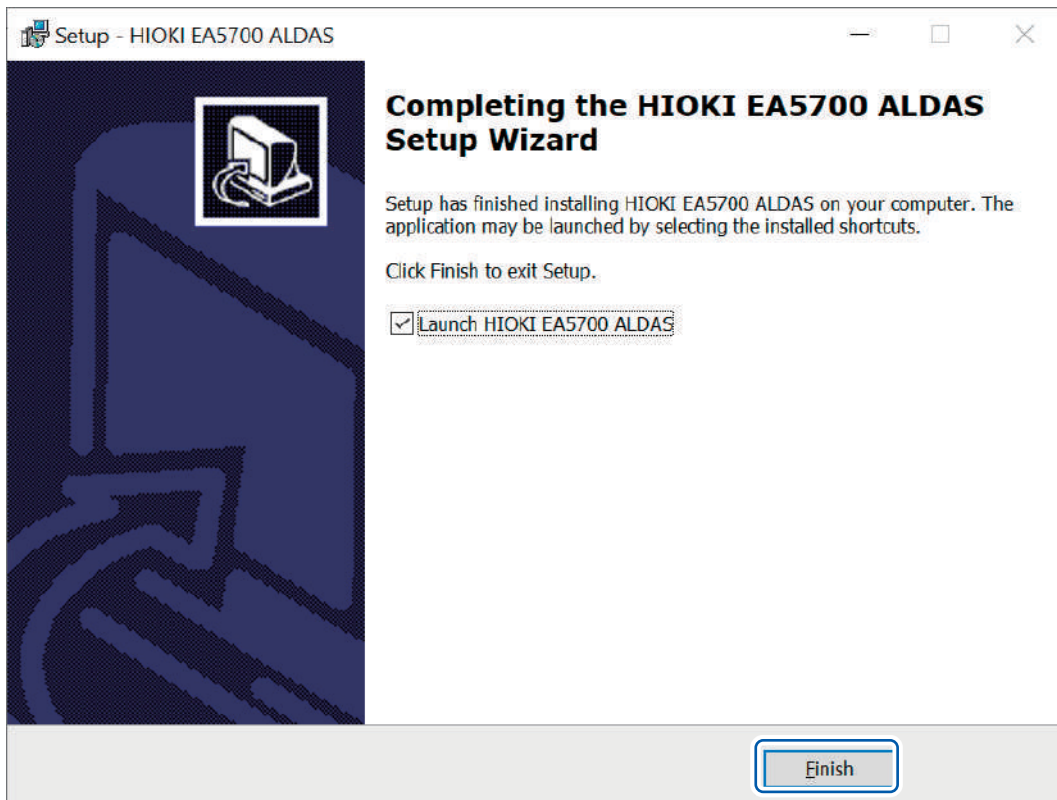

2.3 Connecting the Sense Cable (Voltage Input)

Connect the L1100 Sense Cable to the voltage input terminal on the back of the Sense Module. Connect the necessary number of Sense Cables depending on the number of channels available on your Sense Module and the number of electrolysis cells to be measured.

⚠ WARNING



- **Turn off the DC power source to the measurement target before connecting the cables.**

Failure to do so could potentially damage the modules, resulting in bodily injury.

IMPORTANT

For accurate measurement, ensure the Sense Cable is firmly and fully inserted.

Rear panel of the Sense Module

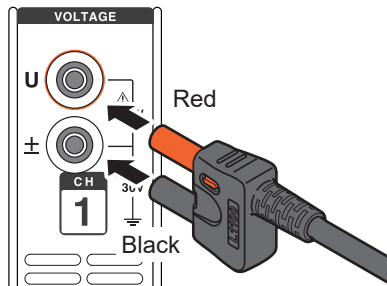

- 1 Turn off the Sense Module.**

- 2 Insert the Sense Cable into the voltage input terminals.**

Insert the red plug into the terminal labeled “U” and the black plug into the terminal labeled “±.”

2.4 Connecting the Current Sensor (Current Input)

Connect the current sensor to the Probe 1 terminal on the Sense Module.

⚠ DANGER

- ⊘
 - **Do not use the current sensors to measure a circuit carrying a voltage greater than the maximum rated line-to-ground voltage.*1**
 - **Do not use the current sensors for measuring bare conductors.**
Doing so could result in serious bodily injury or a short circuit.
*1. For details about the maximum rated line-to-ground voltage of the current sensor, refer to the instruction manual that came with the current sensor.
- !
 - **Connect the current sensor to the Probe 1 terminal only.**
Using a current sensor other than the option listed in this manual may result in serious personal injury.

⚠ CAUTION

- ⊘
 - **Do not connect or disconnect connectors while the modules have been turned on.**
Doing so could damage the sensor.

IMPORTANT

- Do not drop a current sensor onto a floor or other surface.
- Do not subject the current sensor to mechanical shocks.
Doing so could adversely affect the current sensor's measurement accuracy and the opening/closing mechanism.

For detailed specifications and instructions for the current sensors being used, refer to the instruction manual that came with the current sensors.

How to plug the connector

IMPORTANT

Always connect the current sensor to CH1 (Probe 1 terminal) only, even when measuring voltage on multiple channels.

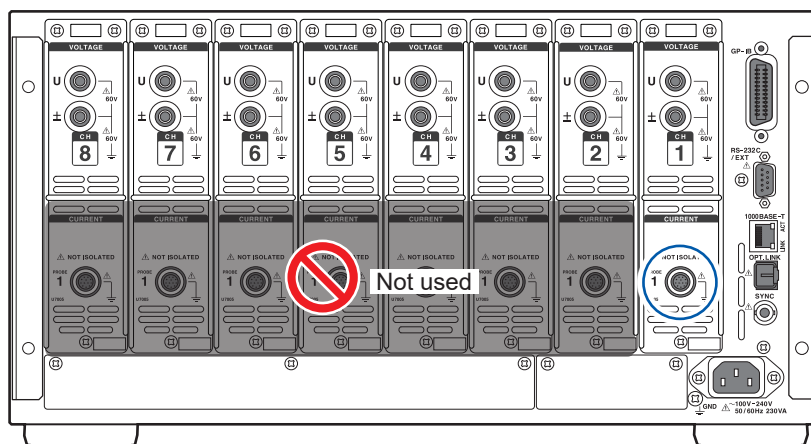

Connecting the Current Sensor (Current Input)

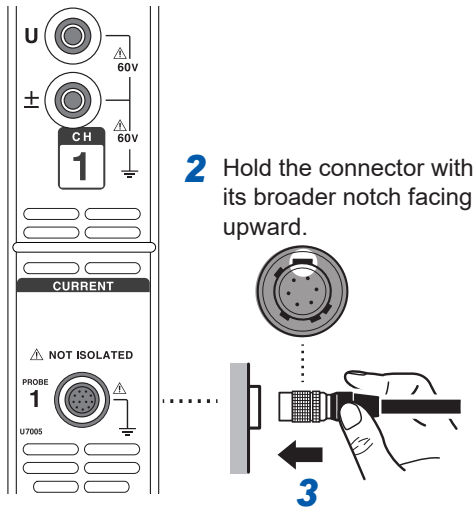

- 1** Turn off the Sense Module.
- 2** Align the positions of the connector guides of the Sense Module and the current sensor.
- 3** Hold the plastic part of the connector and insert it straight until it is locked.

The Sense Module automatically recognizes the type of current sensor when it is plugged in.

How to unplug the connector

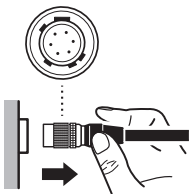

- 1** Hold the metallic part of the connector and slide it toward the cable side to unlock the connector.
- 2** Pull out the connector.

2.5 Connecting the Source Cable

Connect the L1150 Source Cable to the signal superposition terminal on the back of the Source Module.

⚠ WARNING



- Turn off the DC power source to the measurement target before connecting the cords.

Failure to do so could potentially damage the modules, resulting in bodily injury.

IMPORTANT

For accurate measurement, ensure the Source Cable is firmly and fully inserted.

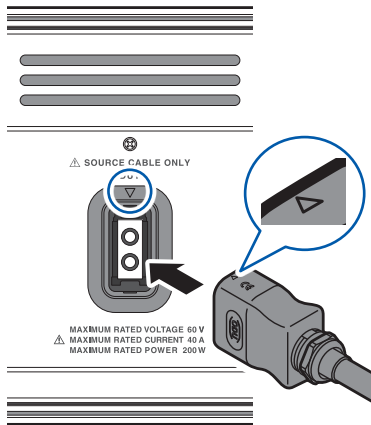

- 1 Turn off ("O") the main breaker for the Source Module.

- 2 Insert the Source Cable into the signal superposition terminal.

Align the ∇ mark on the terminal with the Δ mark on the Source Cable.

2.6 Connecting LAN Cables

Connect LAN cables to the RJ-45 (Gigabit Ethernet) connectors of the modules.

⚠ CAUTION



- **Do not unplug LAN cables while measurement is in progress.**
Doing so could damage the modules and the computer.

- **If routing LAN cables over more than 30 m, attach LAN surge protectors or other suitable protective devices.**



Failure to do so could cause damage to the system due to increased susceptibility to the effects of induced lightning.

- **Turn off the products and computer before connecting or disconnecting cables.**
Failure to do so could damage the modules and the computer being connected or cause them to malfunction.

- 1** Turn off (“O”) the main breaker for the Source Module.
- 2** Connect the Sense Module and Source Module with the LAN cable.
- 3** Connect the Source Module and PC with the LAN cable.

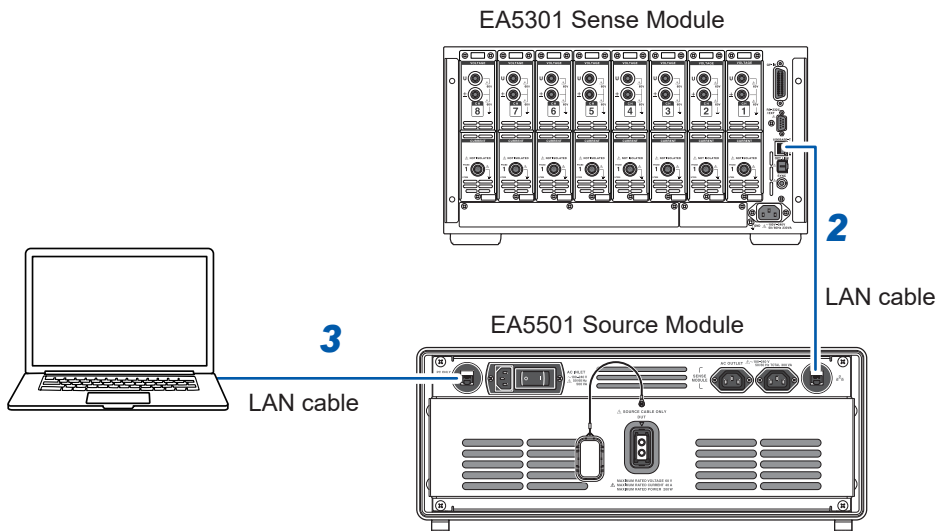

2.7 Connecting the Power Cords

⚠ DANGER



- **Use only the specified power cord to provide power to the modules.**

Using a power cord other than those specified could cause a fire, resulting in serious bodily injury.

⚠ CAUTION



- **Before connecting the power cords, verify that the your supply voltage falls within the supply voltage range noted on the AC inlets of the modules.**

Supplying a voltage that falls outside the specified range to the modules could damage them, causing bodily injury.

- **Ground the ground terminals of the modules and the equipment to be connected at a same location.**

Failure to do so could damage the modules and the devices being connected or cause them to malfunction.

- 1 Turn off both Sense Module and Source Module.
- 2 Connect the specified Source-Sense power cord to the Sense Module power inlet.
- 3 Connect the other end of Sense-Source power cord to the Source Module labeled “SENSE MODULE AC OUTLET”
- 4 Verify that the main power supply voltage falls within the rated range (100 to 240 V AC) and connect the included power cord (for the main power supply) to the Source Module’s power inlet.
- 5 Connect the power cord’s plug to main power supply outlet.

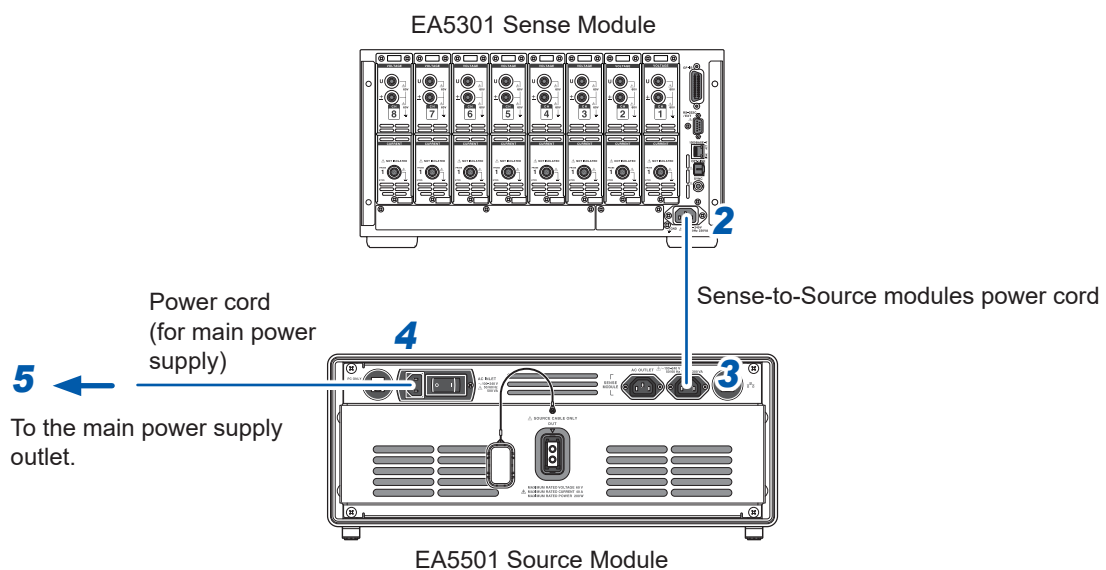

2.8 Connecting to the Measurement Target

Connect the Sense Cables, current sensor, and Source Cable to the measurement target.

DANGER

- **Do not short the positive and negative measurement lines with the metal part of the Sense Cable clip.**



Doing so can cause arc flash, resulting in serious bodily injury or damage to the system or other equipment.

- **Never touch the metal areas on test leads or at the tips of voltage cords during measurement.**

Doing so could result in serious bodily injury or a short circuit.

WARNING



- **After turning off the measurement target's power and the modules, connect the Sense Cables, current sensor, and Source Cable.**

Doing so could damage the products, resulting in bodily injury.

CAUTION



- **Connect the red clip of the Source Cable to the positive terminal [high-potential] and the black clip to the negative terminal [low-potential].**

Connecting the cables with incorrect polarity can cause damage to the Source Module.

- 1 Turn off the DC power supply to the measurement target and verify that it is completely de-energized.**
- 2 Confirm that the measurement system (Sense and Source modules) is turned off.**
- 3 Use the relay cables (Ⓞ) to connect the positive and negative sides of the measurement target to the Source Cable.**

The relay cable is not provided with this product. Please prepare a suitable relay cable in compliance with the measurement target (electrolysis cell) DC current specification.

Two relay cables are required (for positive and negative sides).

Example of a relay cable:  Length: About 20 cm

4 Securely clip the Source Cable to the contact point (A) of the relay cable.

Connect the red clip to the positive terminal (high potential) and the black clip to the negative terminal (low potential).

5 Clip the Sense Cable securely to position (B) where the voltage of the measurement target can be detected.

Please clip the Sense Cable to the points where the voltage of the measurement target can be measured.

6 Clamp the current sensor around the relay cable (C) connected to the measurement target.

Choose one of the relay cables for current measurement, either the positive or negative side, and follow the current sensor direction below.

DC Power supply or Source Module

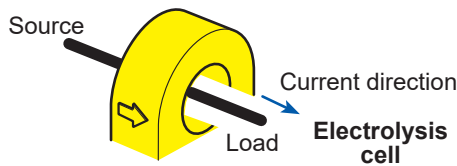

Fuel cell

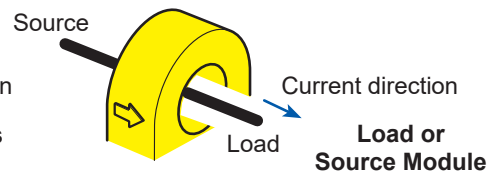

OK

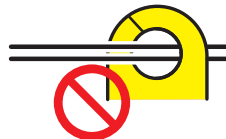

NO

Do not clamp the sensor around two or more conductors.

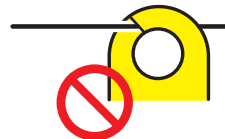

NO

Do not pinch the conductor.

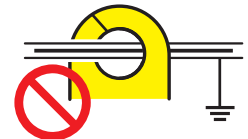

NO

Do not clamp the sensor to a shielded wire.

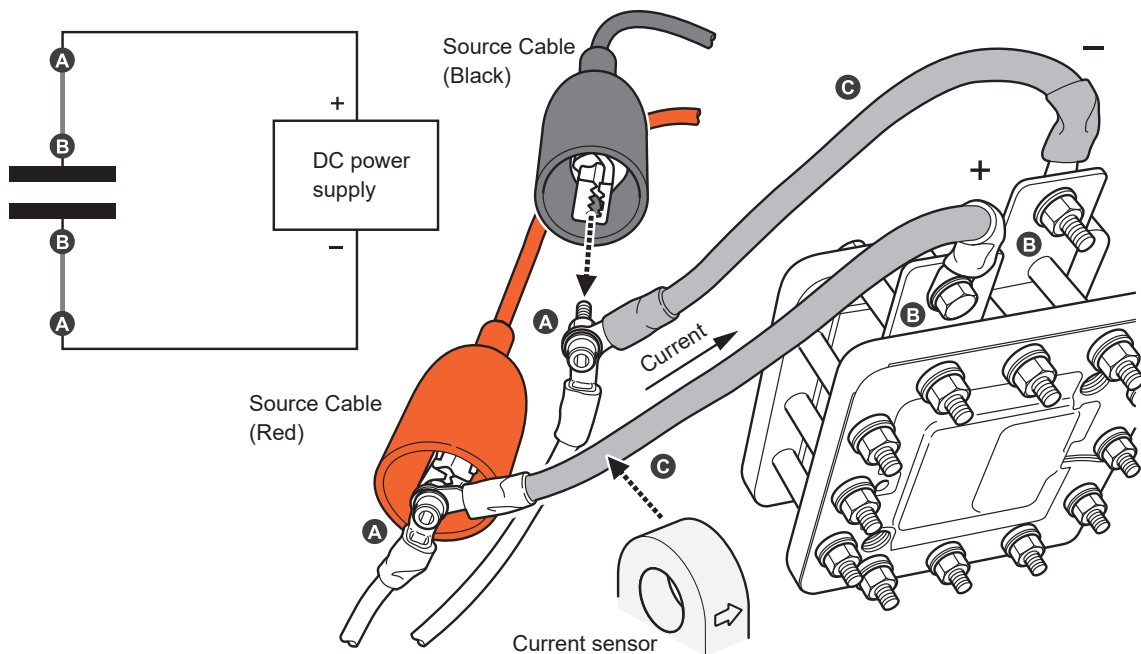

Connection Diagram

(1) For a single cell

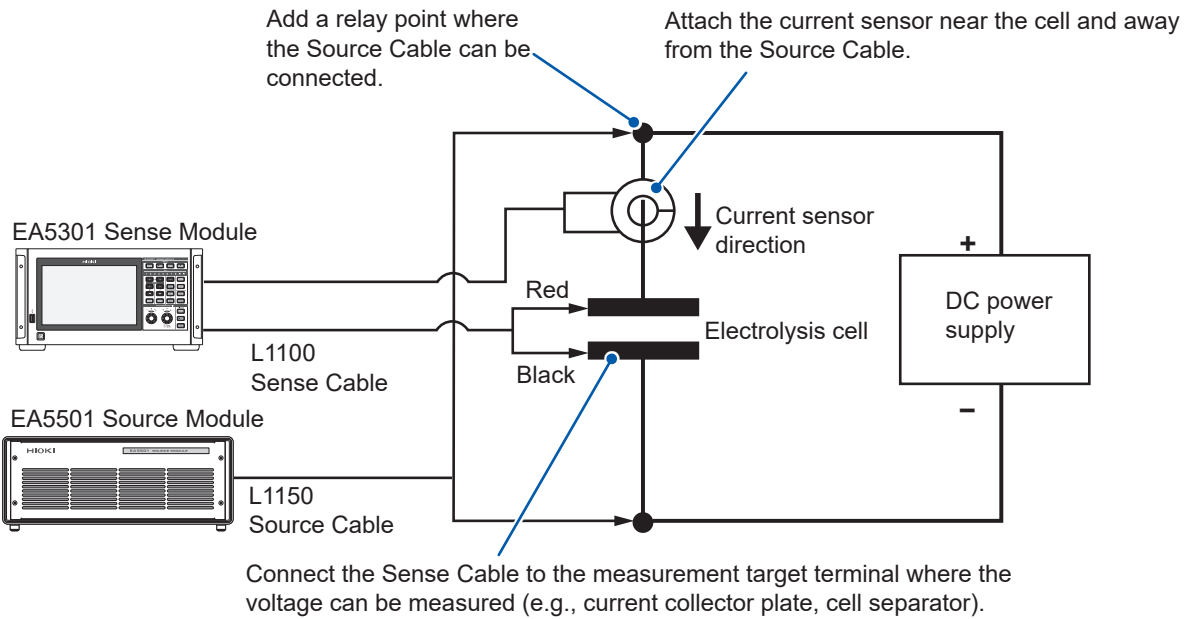

- For fuel cell configuration with a load: Reverse the current sensor direction relative to the diagram above.

(2) For multiple cells (stack)

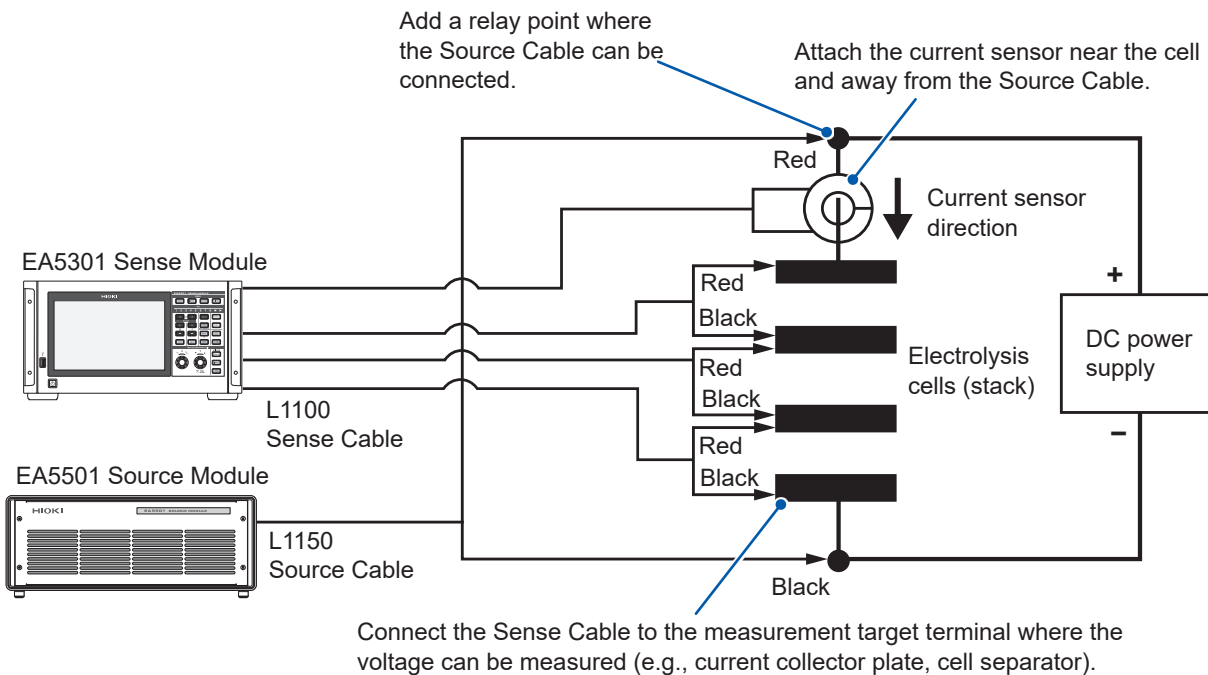

- For fuel cell stack configuration with a load: Reverse the current sensor direction relative to the diagram above.

2.9 Supplying Power to the System

Turn on the system

- 1 Switch on (“I”) the Source Module main breaker.**
The Source Module will start up.
- 2 Press the POWER button on the Sense Module.**
The Sense Module is turned on.
- 3 Let the system warm-up for at least 30 minutes before starting the measurement.**

Turn off the system

CAUTION



- **Ensure the measurement target’s DC power supply is turned off and the system detects no voltage or current before shutting down the system.**
Failure to do so may result in system damage.

- 1 Turn off the measurement target’s DC power supply.**
- 2 Verify that there is no voltage or current detected from the measurement target by the Sense Module.**
- 3 Press the Power button on the Sense Module to switch it off.**
The Sense Module will turn off.
- 4 Switch off (“O”) the Source Module main breaker.**
The Source Module will turn off.

2.10 Performing Zero Adjustment and Degaussing (DMAG)

Zero adjustment is performed for all input channel ranges simultaneously. The current sensor will also be degaussed (DMAG) at the same time.

- 1 Verify that the measurement target is powered off and has no input detected for both voltage and current measurement.
- 2 Press the **MEAS** key (p.18).
- 3 Press the **0ADJ** key (p.18).
- 4 If a confirmation dialog is shown on the Sense Module's display, tap **[Yes]**.

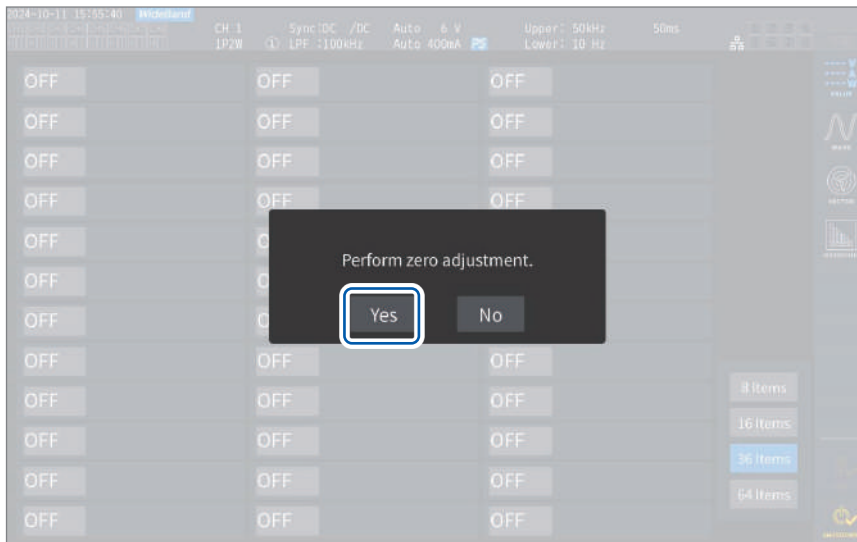

The message **[Performing zero adjustment...]** will be displayed, and zero adjustment will complete in about 30 seconds.

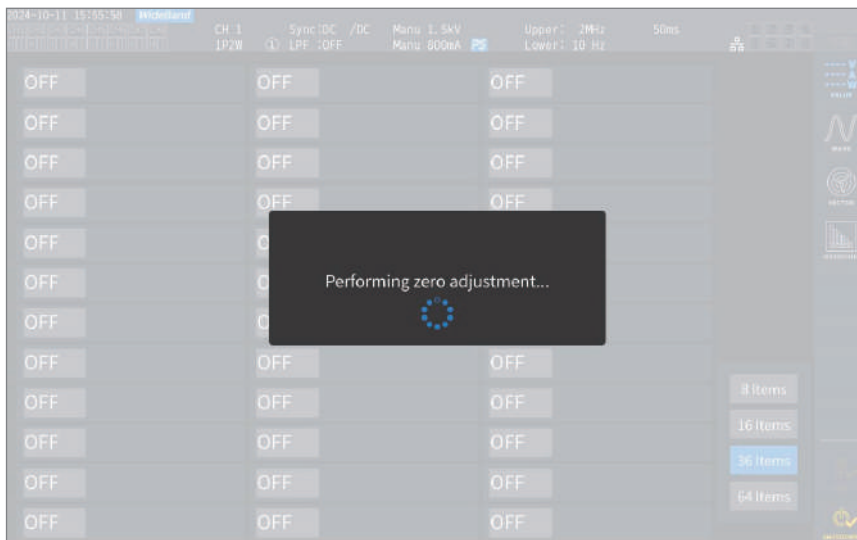

3

Configuring the PC Application

USB dongle key

CAUTION



- Take steps to ensure that static electricity is not applied to the USB dongle key.

Application of static electricity could damage the USB dongle key, or cause the system to malfunction. Additionally, the system could fail to start.

IMPORTANT

The EA5700 ALDAS will perform license authentication when it is launched and starts measurement. Do not remove the USB dongle key while the application is running.

Insert the USB dongle key into the PC's USB port.

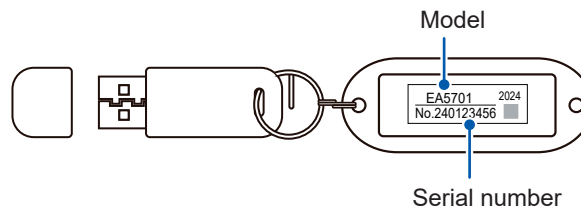

3.1 Launching the EA5700 ALDAS (PC Application)

- 1 Insert the USB dongle key into the USB port of the PC with the EA5700 ALDAS installed.
- 2 Double-click the  icon on your PC desktop to launch the EA5700 ALDAS after installing the PC application (p.26).

The EA5700 ALDAS window will open.

If the USB dongle key is not inserted when the EA5700 ALDAS is launched, a pop-up message shown below will be displayed.

Click **[OK]** to exit the application and then relaunch the application after inserting the USB dongle key.

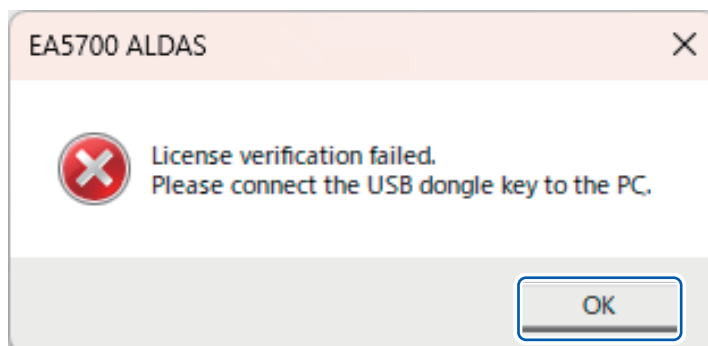

3.2 Creating a Measurement Project

A measurement project's file consists of measurement conditions, hardware information, measurement target information and measurement results. When you open a project file [**ProjectName.aldasproj**], you can restore and load information such as the previous measurement results and setting conditions. Follow the steps below to create a measurement project.

- 1 Click [**New**] in the [**HOME**] tab.
[**Project Settings**] window will be displayed.

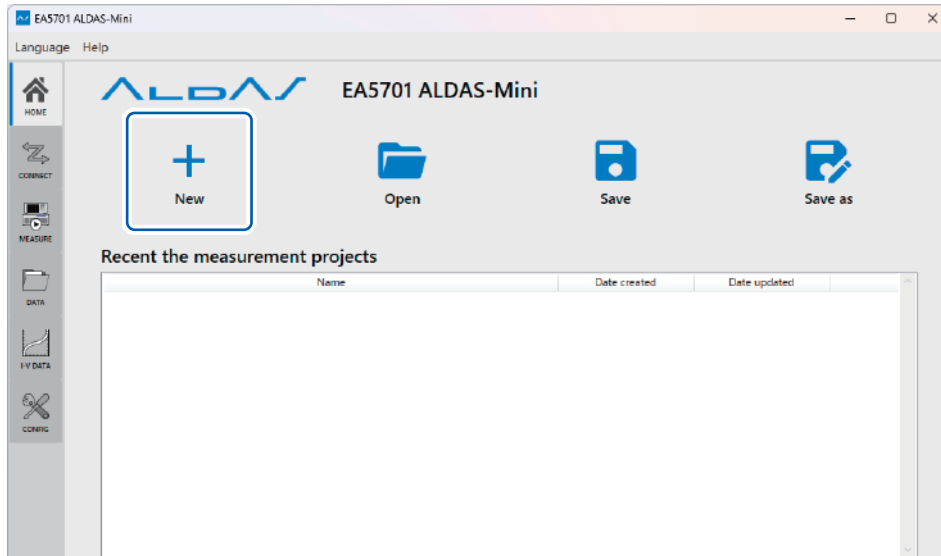

- 2 Click [**Browse**] to select the location to save the project file.

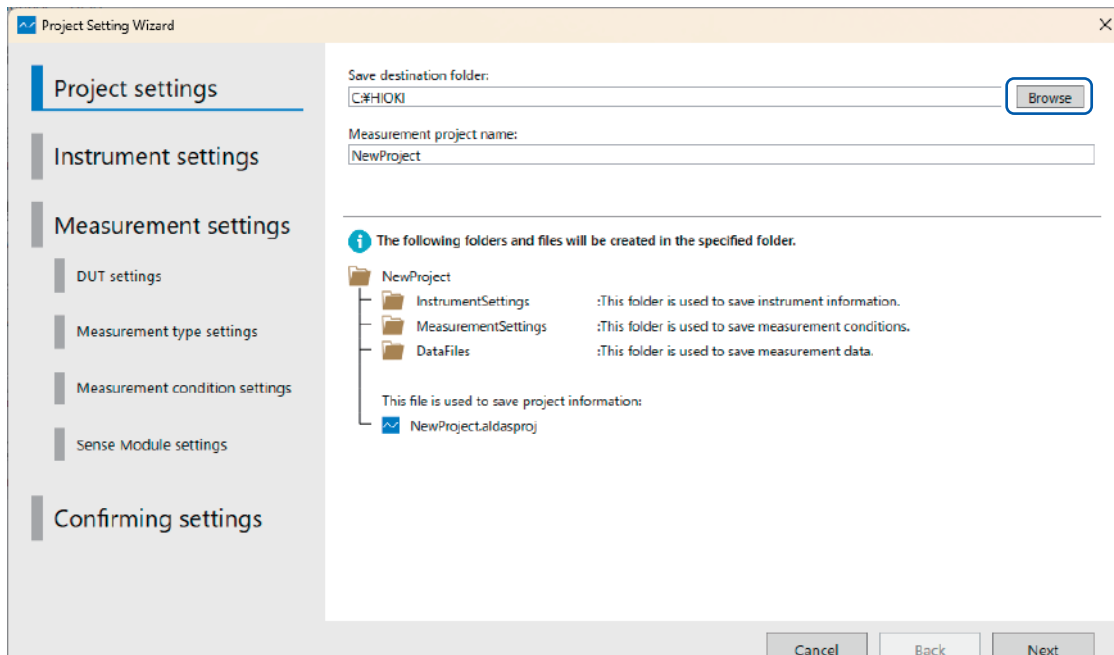

3 Click [Select Folder].

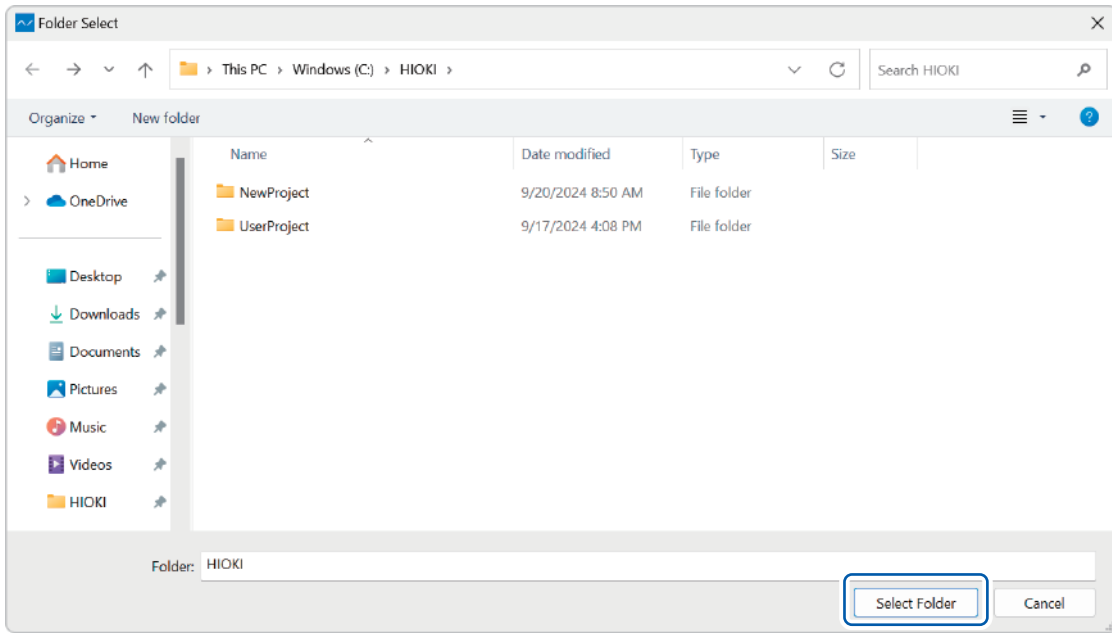

4 Specify the project name in the [Instrumentation project name] text box.

An error will be displayed if a project folder with the same name already exists in the specified directory. Specify a different name.

5 Click [Next].

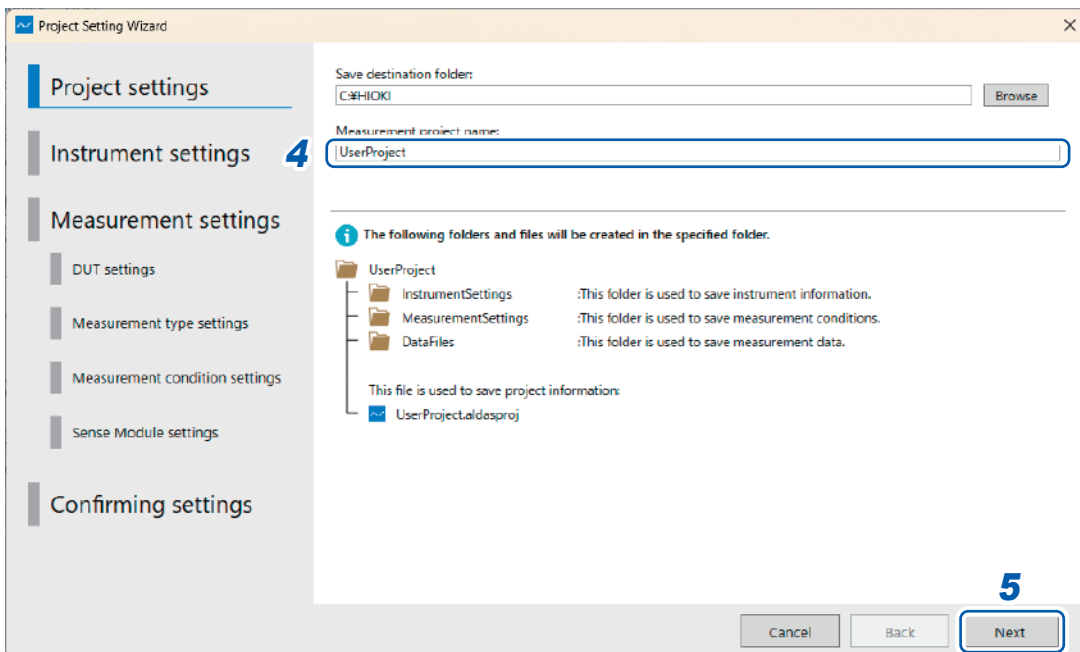

3.3 Connecting to the System Instruments

The PC environment needs to be set up to connect and communicate with the system instruments, which include the Sense Module (equipped with a current sensor and Sense Cables) and Source Module (equipped with a Source Cable), that are involved in the measurement process.

If the initial configuration has been completed

A message indicating that the connection is successful will be displayed.

Click **[Next]** and proceed to “3.4 Setting the Measurement Method” (p.46).

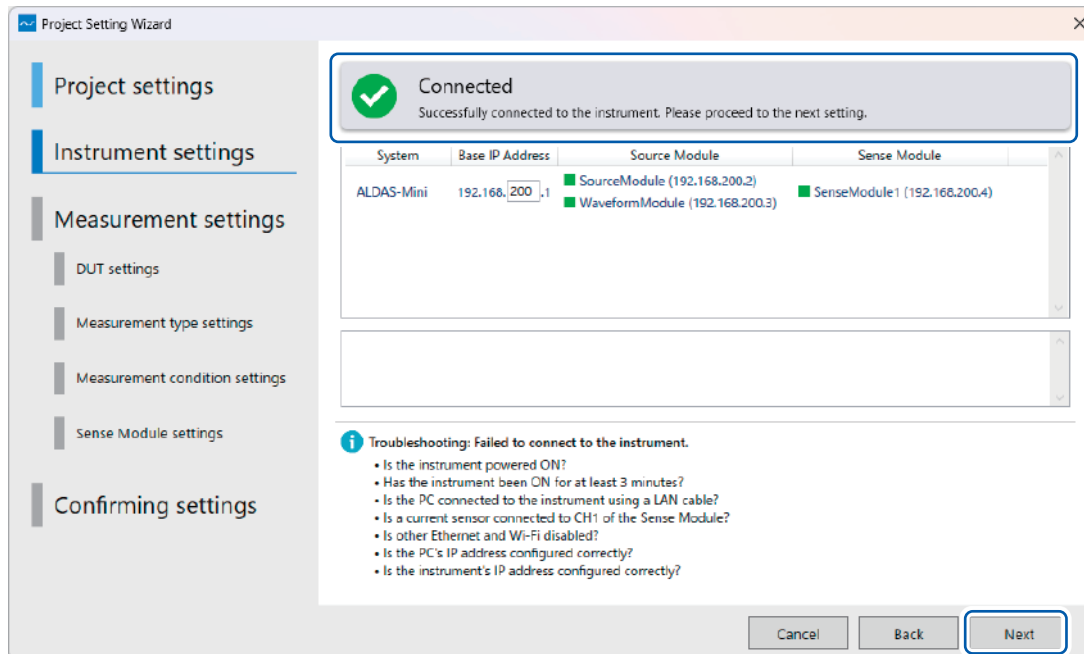

IMPORTANT

After turning on the Source Module, wait at least 3 minutes for it to warm-up before starting the measurement.

If the initial setup is incomplete

A message indicating that the PC application failed to connect to the measurement system will be displayed.

- 1 Check that both Sense Module and Source Module are turned on and connected to the PC via LAN cable. Then, click **[Not connected]**.

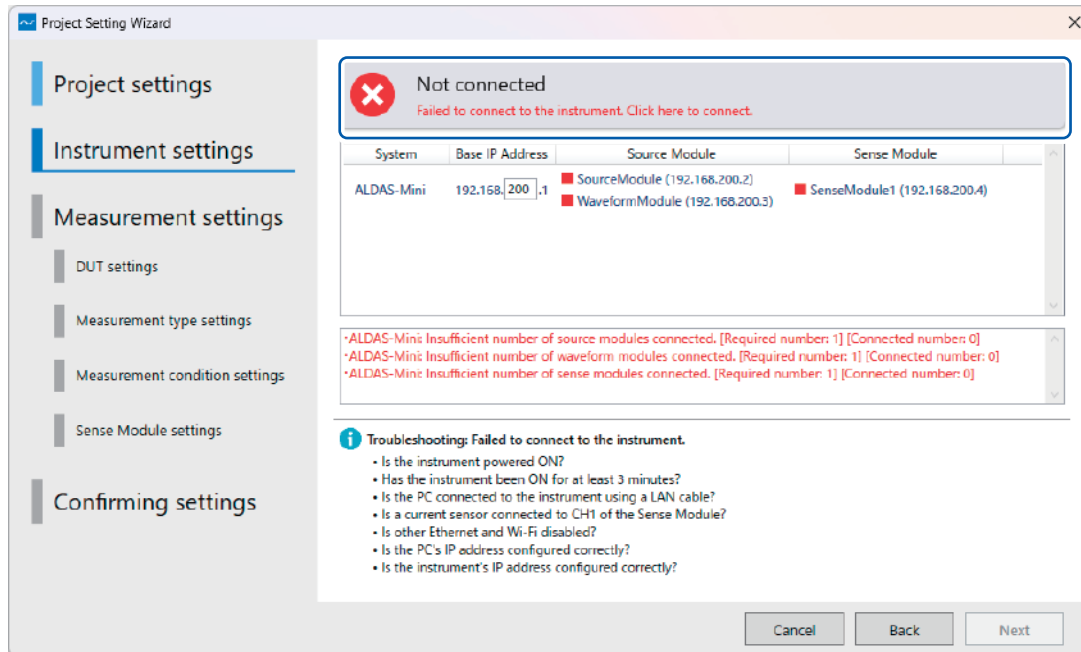

If the settings have been configured properly, a message indicating that the connection is successful will be displayed.

IMPORTANT

If you are having trouble with the connections, please check the following troubleshooting points:

- Is the instrument powered ON?
- Has the instrument been ON for at least 3 minutes?
- Is the PC connected to the instrument using a LAN cable?
- Is a current sensor connected to CH1 of the Sense Module?
- Is the PC's IP address configured correctly?
- Is the instrument's IP address configured correctly?

3.4 Setting the Measurement Method

This section provides guidance on how to set types of measurements, measurement conditions, as well as settings for the Source and Sense Module.

Setting the measurement target (DUT)

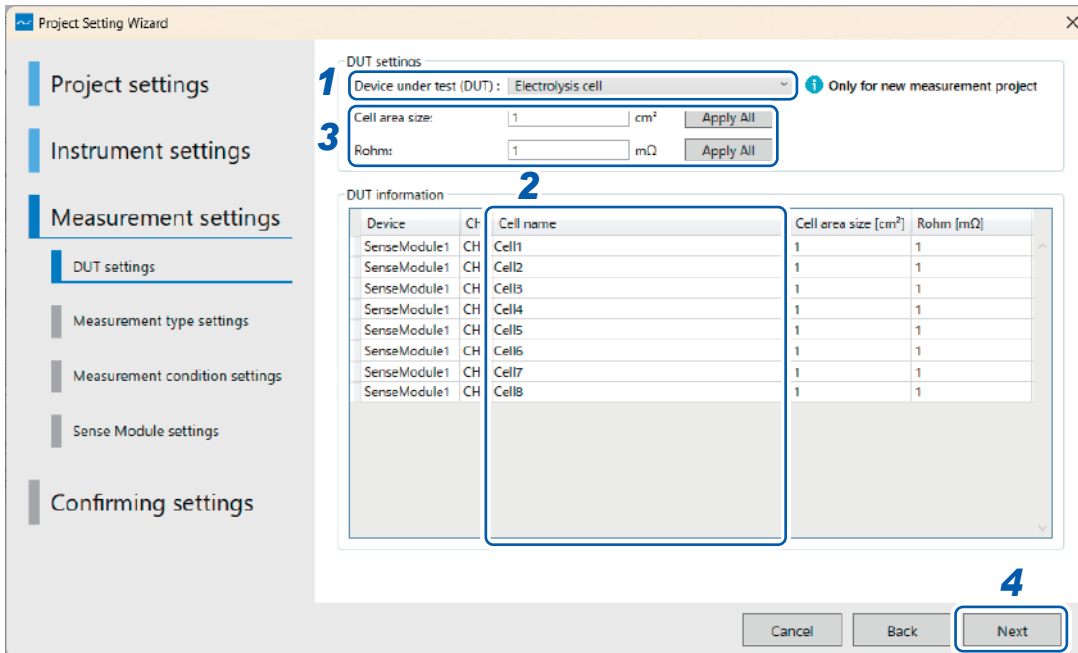

- 1 (When creating a new project file) Select **[Device under test (DUT)]**.

Electrolysis cell	EC: Electrolysis Cell
Fuel cell	FC: Fuel Cell

To change the measurement target (DUT), create a new project file.

- 2 Enter the name in **[Cell name]**.

The assigned name here will be shown in the graph legend. For the I-V graph, each cell name will have its own respective I-V plot. Multiple cells will result in multiple I-V curves on the same graph.

- 3 Enter values in **[Cell area size]** and **[Rohm]**.

Cell area size	By default, the cell size area size is set to “1”, but you can modify this value. The cell area size value is used to calculate the cell’s performance display in the I-V graph with current density. Specify “1”, which is the default value, in the following cases: <ul style="list-style-type: none"> • The current density display is not selected • The parameters are unknown • The parameter of the cell area size, etc. is not applicable to the measurement target
Rohm	Specifies the cell’s ohmic resistance. This value is used to calculate IRfree plots. If no value is specified, the default value is 1 mΩ.

- 4 Click **[Next]**.

The measurement method settings window will be displayed.

Setting the measurement method

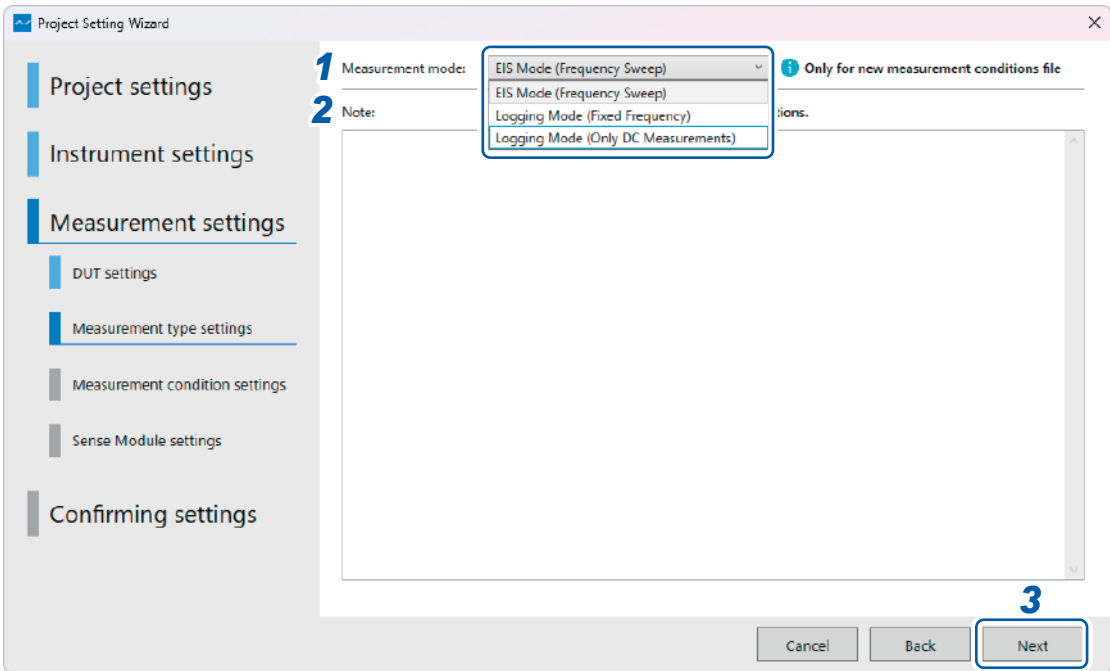

3

Configuring the PC Application

1 Select [Measurement mode].

IMPORTANT
 If the PC goes into sleep mode during measurement, the measurement will stop. Please check your PC's power settings beforehand.

EIS Mode (Frequency Sweep)	Measures impedance while sweeping through a range of frequencies.
Logging Mode (Fixed Frequency)	Measures impedance continuously according to the specified frequency and measurement interval.
Logging Mode (Only DC Measurements)	Measures the DC voltage and current continuously according to the specified interval.

2 Enter any text in [Note].

You can enter and save the measurement conditions and other necessary notes as text and link them with the measurement data.

3 Click [Next].

The measurement conditions settings window will be displayed according to the measurement mode selected.
 "Setting the EIS Mode measurement method" (p.48)
 "Setting the Logging Mode (Fixed Frequency) measurement method" (p.50)
 "Setting the Logging Mode (Only DC Measurements) measurement method" (p.52)

Setting the EIS Mode measurement method

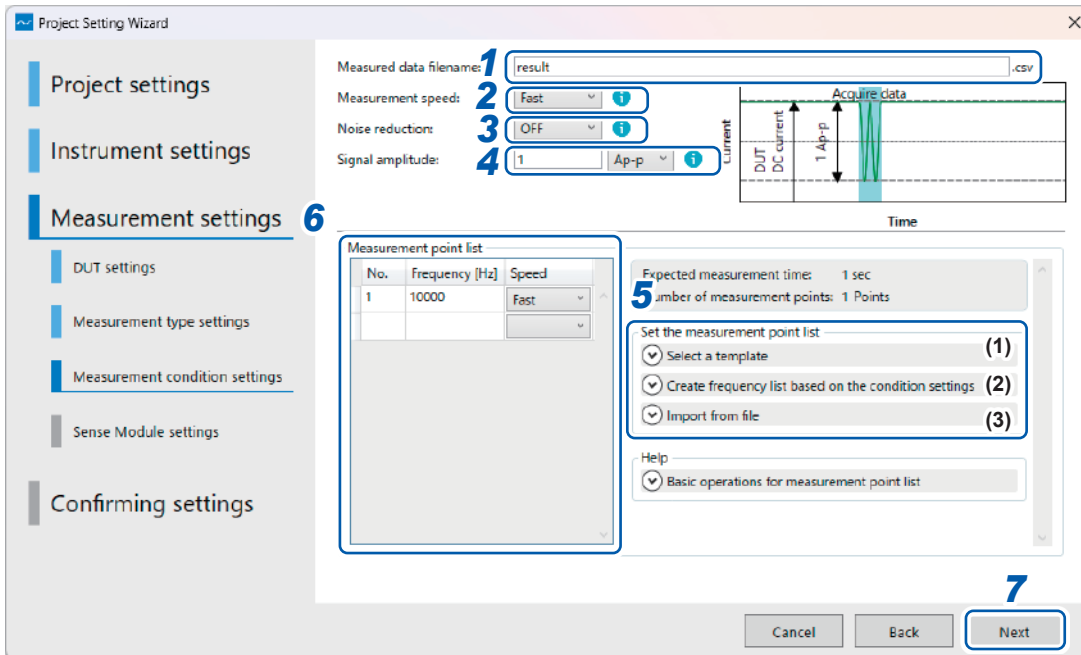

1 Specify the measurement results filename to save in the [Measured data filename] text box.

The results file will be saved in the [DataFiles] folder in the project folder. If a file with the same name already exists in the [DataFiles] folder, an incremented number will be appended to the end of the filename, for example [Filename_1.csv].

2 Select the measurement priority under [Measurement speed].

Fast	The measurement speed takes precedence over stability. This measurement speed yields the least stable results among all the others.
Medium	The measurement process ensures a balance between measurement speed and measurement stability.
Slow	Priority is given to the measurement stability when taking measurements. As the number of measurements increases, the measurement speed slows down compared to other modes.

3 Select the filter for suppressing noise under [Noise reduction].

OFF	Disables noise reduction.
ON	Reduces the noise generated at frequencies higher than the measurement signal frequency.

4 Specify the measurement signals' amplitude in the [Signal amplitude] text box.

You can select the peak-to-peak or RMS current.

IMPORTANT

Set the measurement signal amplitude according to the measurement target specifications. Start with the amplitude value at around 5% of the measurement target DC current value. Setting the amplitude too small will result in an unstable impedance measurement. Setting the amplitude too large will cause the measurement target current to fluctuate significantly due to the applied measurement signal. Refer to “Impedance measurement during DC operation” (p. 121) for further details.

5 Select a method to generate the measurement signal's [Set the measurement point list] below:

(1) [Select a template]

Select frequency range template via drop down menu.

Conditions will be registered in the frequency list when they are selected from the combo box.

(2) [Create frequency list based on condition settings]

Generate the frequency list by specifying parameters such as start frequency, end frequency, and number of points. The conditions will be registered in the frequency list when you click the [Create] button after configuring the settings.

(3) [Import from file]

Load the frequency list from a CSV file. When you click [Browse] and select a file, the measurement signal's frequencies will be loaded and registered in the frequency list. CSV files must satisfy the following conditions:

- Each frequency value must be separated by a newline codes.
- Frequency values must be within the range of 0.01 Hz to 10000 Hz.
- Frequency values must have no more than two significant figures.

Example: 1200 Hz satisfies the conditions, but 1230 Hz does not.

If a value does not satisfy the conditions, it will be converted automatically to the nearest two significant figures value.

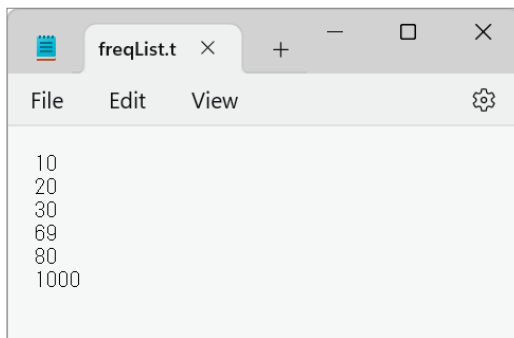

6 Edit the [Measurement point list] (if necessary).

Perform measurement at the frequencies displayed in [Measurement point list].

Double-click each number in the [Frequency] column to change the measurement signal frequency.

For more information about the resolution at which frequencies can be set, see "Impedance measurement frequency resolution" (p.102) in the specifications.

The [Expected measurement time] and [Number of measurement points] will be displayed to the right of the list. Measurement time can vary depending on the measurement conditions. Use this information as a guide when creating conditions.

Noted that the maximum number of measurement points is 1000.

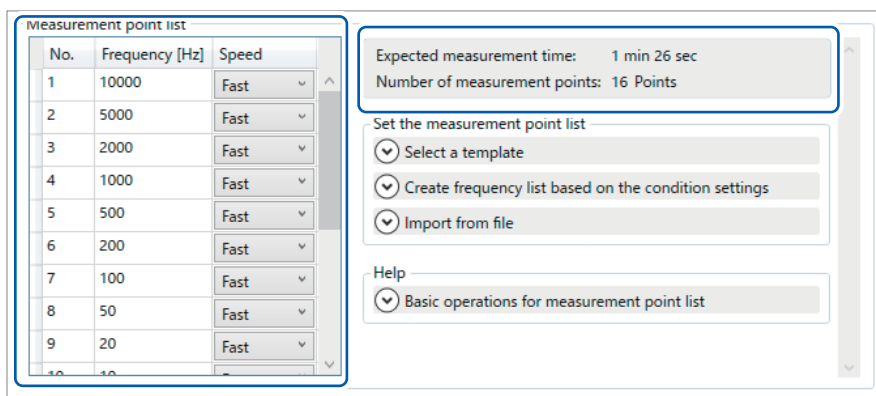

7 Click [Next].

Proceed to "Configuring the Sense Module" (p.54).

Setting the Logging Mode (Fixed Frequency) measurement method

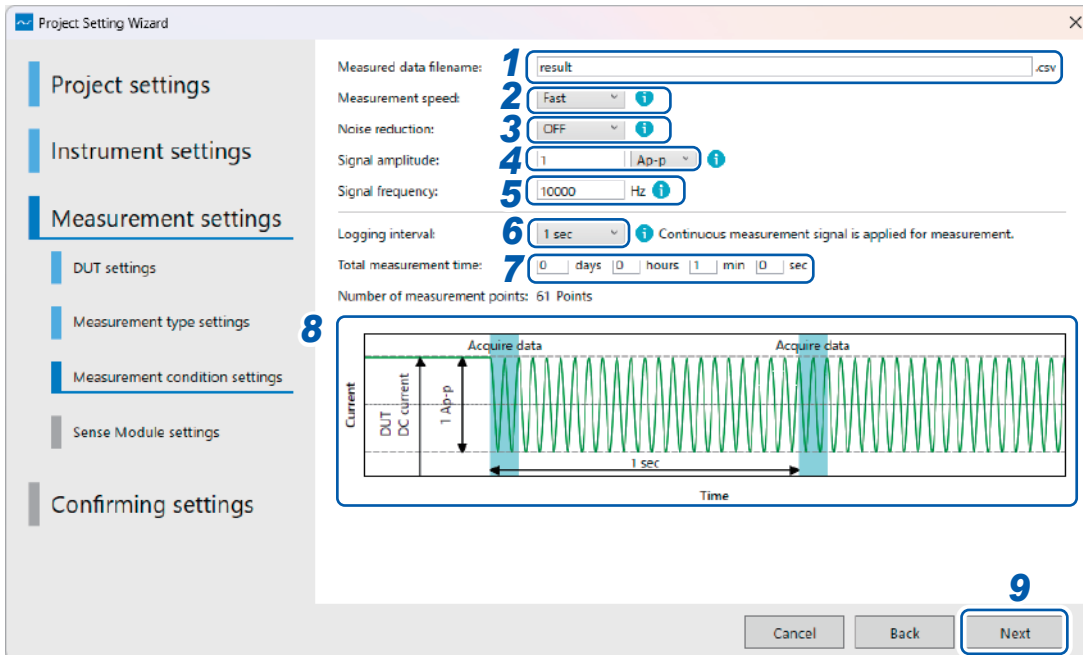

1 Specify the measurement results filename to save in the **[Measured data filename]** text box. The results file will be saved in the **[DataFiles]** folder in the project folder. If a file with the same name already exists in the **[DataFiles]** folder, an incremented number will be appended to the end of the filename, for instance **[Filename_1.csv]**.

2 Select measurement priority under **[Measurement speed]**.

Fast	The measurement speed takes precedence over stability. This measurement speed yields the least stable results among all the others.
Medium	The measurement process ensures a balance between measurement speed and measurement stability.
Slow	Priority is given to the measurement stability when taking measurements. As the number of measurements increases, the measurement speed slows down compared to other modes.

3 Select the filter for suppressing noise under **[Noise reduction]**.

OFF	Disables noise reduction.
ON	Reduces the noise generated at frequencies higher than the measurement signal frequency.

4 Specify the measurement signals' amplitude in the [Signal amplitude] text box.

You can select the unit in the peak-to-peak or RMS current.

IMPORTANT

Set the measurement signal amplitude according to the measurement target specifications.

Start with the amplitude value at around 5% of the measurement target DC current value.

Setting the amplitude too small will result in an unstable impedance measurement.

Setting the amplitude too large will cause the measurement target current to fluctuate significantly due to the applied measurement signal.

Refer to "Impedance measurement during DC operation" (p. 121) for further details.

5 Specify the measurement signal's frequency in the [Signal frequency] text box.

For more information about the resolution at which frequencies can be set, see "Impedance measurement frequency resolution" (p. 102) in the specifications.

6 Select the data acquisition interval under [Logging interval].**7 Specify the total time until measurement is stopped under [Total measurement time].**

The [Number of measurement points] during the interval will be automatically calculated from the [Logging interval] and the [Total measurement time].

The maximum number of measurement points is 5000. Setting exceeding this value will be deemed invalid.

Change the [Logging interval] or [Logging total time] setting so that the number of measurements is 5000 or less.

The screenshot shows a configuration window with the following fields:

- Logging interval:** A dropdown menu set to "1 sec". To its right is an information icon and the text "Continuous measurement signal is applied for measurement."
- Total measurement time:** A series of input boxes for "days", "hours", "min", and "sec". The values are 0, 0, 1, and 0 respectively.
- Number of measurement points:** An input box containing the value "61 Points".

8 Check the current waveform during signal superposition.

The illustration shows the measurement time sequence with time against current graph.

The graph changes when the user inputs signal frequency, signal amplitude, logging interval, and speed.

There are two ways the measurement signal can be applied: continuously or at discrete intervals. The system automatically selects the appropriate mode depending on the measurement parameters.

The discrete measurement signal is applied when there is long intervals between measurement.

The continuous measurement signal is applied when there is short intervals between the measurements. In this case, the DC voltage and DC current is recorded only at the beginning of the measurement.

9 Click [Next].

Proceed to "Configuring the Sense Module" (p. 54).

Setting the Logging Mode (Only DC Measurements) measurement method

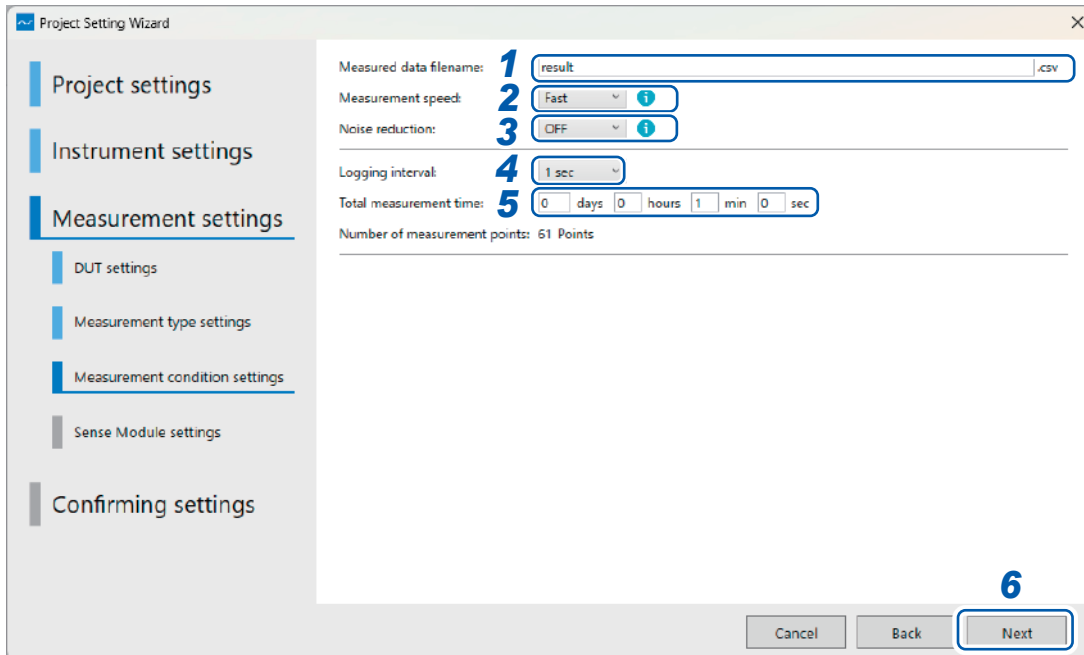

1 Specify the measurement results filename to save in the **[Measured data filename]** text box.

The results file will be saved in the **[DataFiles]** folder in the project folder. If a file with the same name already exists in the **[DataFiles]** folder, an incremented number will be appended to the end of the filename, for instance **[Filename_1.csv]**.

2 Select measurement priority under **[Measurement speed]**.

Fast	The measurement speed takes precedence over stability. This measurement speed yields the least stable results among all the others.
Medium	The measurement process ensures a balance between measurement speed and measurement stability.
Slow	Priority is given to the measurement stability when taking measurements. As the number of measurements increases, the measurement speed slows down compared to other modes.

3 Select the filter for suppressing noise under **[Noise reduction]**.

OFF	Disables noise reduction.
ON	Reduces the noise generated at frequencies higher than the measurement signal frequency.

4 Select the data acquisition interval under **[Logging interval]**.

5 Specify the total time until measurement is stopped under [Total measurement time].

The [Number of measurement points] during the interval will be automatically calculated from the [Logging interval] and the [Total measurement time].

The maximum number of measurement points is 5000. Setting exceeding this value will be deemed invalid. Change the [Logging interval] or [Logging total time] setting so that the number of measurements is 5000 or less.

Logging interval:	<input type="text" value="1 sec"/>	Continuous measurement signal is applied for measurement.
Total measurement time:	<input type="text" value="0"/> days <input type="text" value="0"/> hours <input type="text" value="1"/> min <input type="text" value="0"/> sec	
Number of measurement points	<input type="text" value="61 Points"/>	

6 Click [Next].

Proceed to “Configuring the Sense Module” (p.54).

Configuring the Sense Module

A Sense Module settings screen will be displayed according to the type of Sense Module connected in “3.3 Connecting to the System Instruments” (p.44).

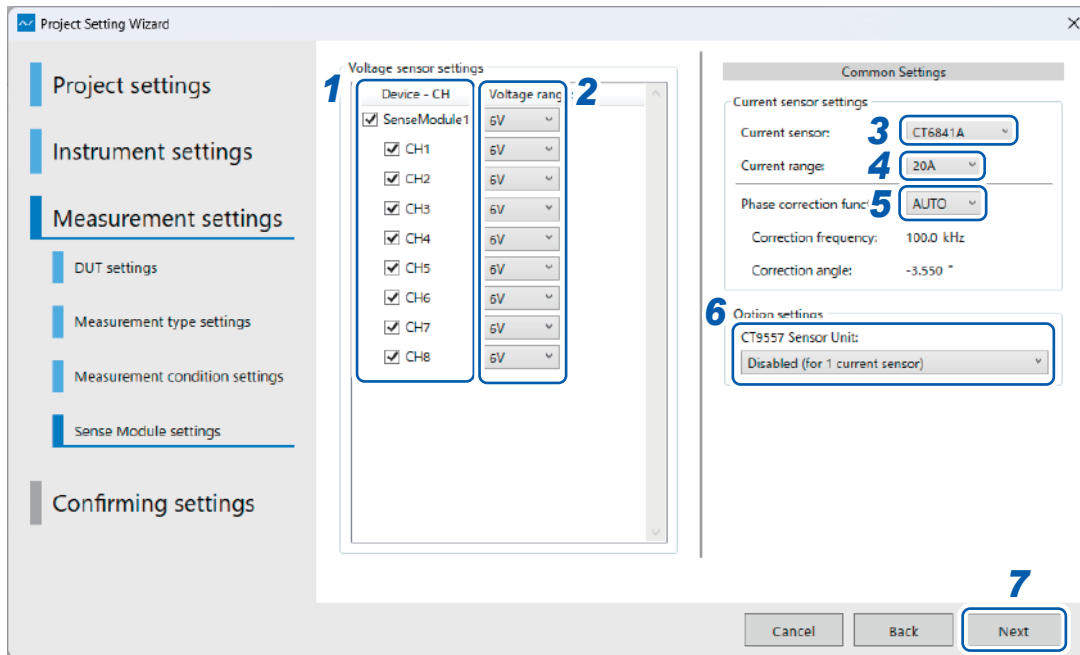

1 Select [Device - CH] checkboxes.

Select the channels you want to measure. Only channels with a checked box will be included. The default setting selects all the check boxes. Please deselect the check box for the channels that are not used for measurement.

2 Set each channel's range under [Voltage range].

The voltage range must be set larger than the measurement target's load voltage.

3 Verify that the model name displayed in [Current Sensor] matches the model name of the connected current sensor.

See “2.4 Connecting the Current Sensor (Current Input)” (p.31).

4 Specify the current range of the current sensor used to measure impedance under [Current range].

The current range must be set larger than the measurement target's DC power supply.

5 Select the phase correction function under [Phase correction function].

There are two types of phase correction functions:

AUTO	Performs phase correction using the correction values registered for each sensor.
OFF	Does not perform phase correction.

6 (When using the CT9557 Sensor Unit) In [CT9557 Sensor Unit], configure the settings for the CT9557 Sensor Unit.

Select [Enabled], and then select the number of sensors connected to the sensor unit.

7 Click [Next].

Proceed to “Review measurement settings” (p.55).

Review measurement settings



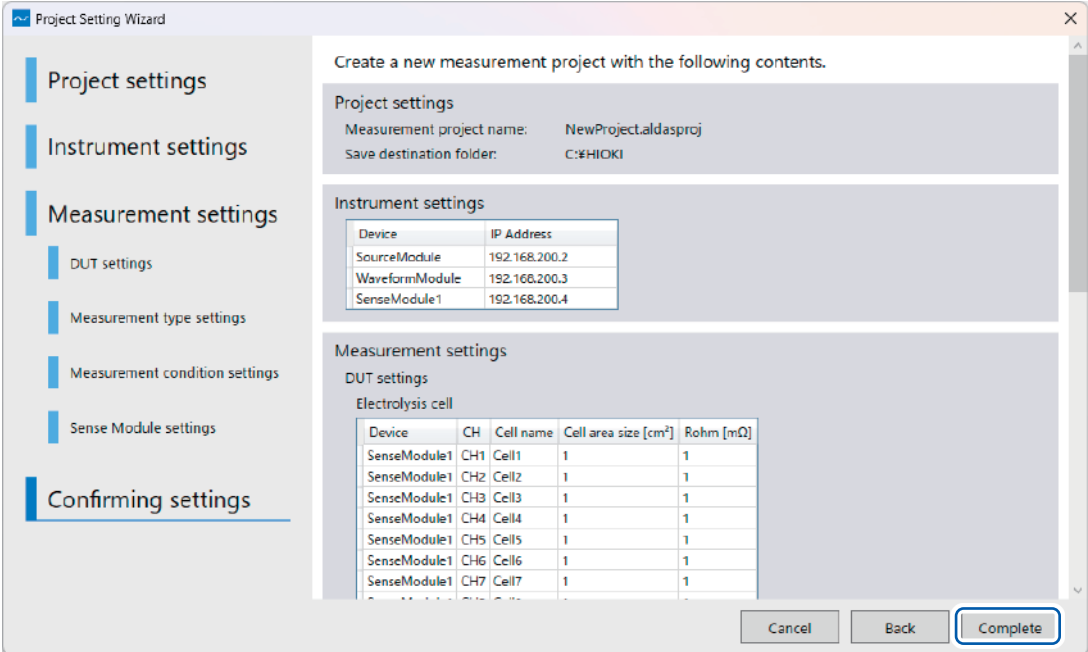



Review the project, instrument, and measurement settings.
Click **[Complete]** to finish the measurement setup.

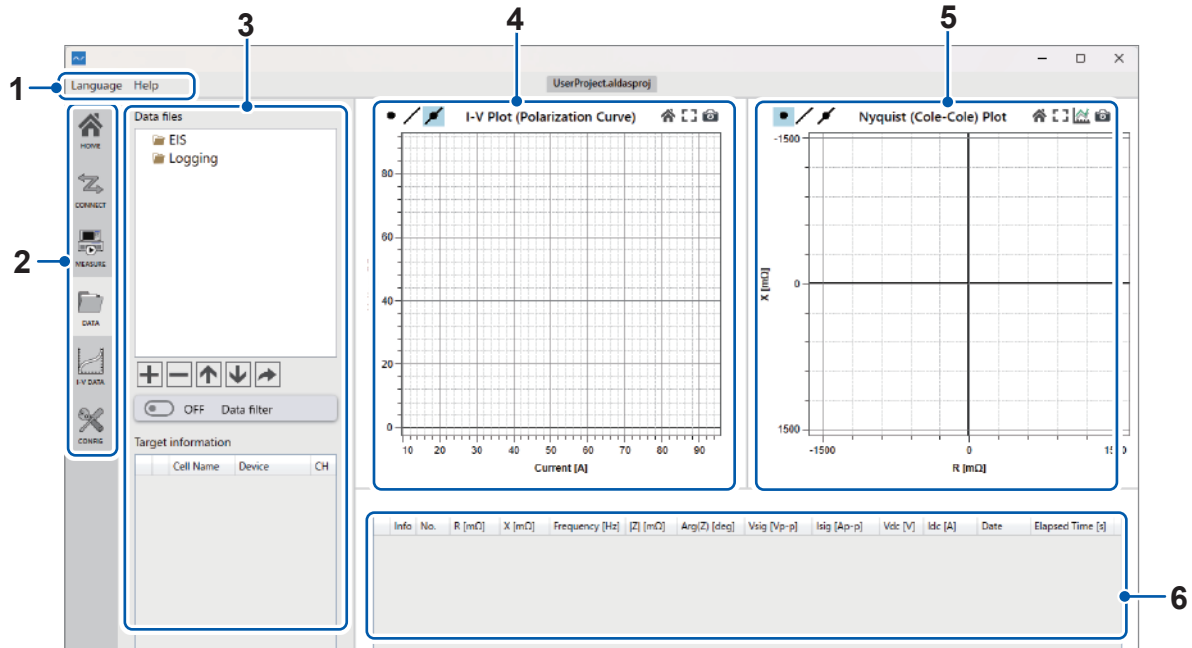

3.5 Main Application Window Overview

The main application window will be displayed after completing the measurement setup.



1	Menu bar	Language	The application language can be changed and selected here.	
		Help	The Help menu contains the application information and the instruction manual.	
2	Tab list		Home	Displays windows to create, save, and open project files.
			Connection settings	Displays a [Connection status] button.
			Measurement settings	Displays a list of measurement condition files, measurement start and stop buttons, and measurement progress.
			Measurement data	Displays a list of data files.
			I-V data	Displays a list of I-V data.
			Configuration settings	Display graph and data table settings.
3	Side menu	Displays settings for the function selected in the tab list.		
4	I-V graph	Displays the relationship between current (or current density) and voltage.		
5	Impedance graph	Displays impedance graph, either Nyquist (Cole-Cole) or Bode plot.		
6	Data table	Displays detailed measurement data from the selected file in a table.		

3.6 Measurement Project Files and Folders

Verify that the following folders and files have been generated in the directory you specified in “3.2 Creating a Measurement Project” (p.42):

[Specified project name] directory

- [DataFiles] directory
- [InstrumentSettings] directory
- [MeasurementSettings] directory
- [Specified project name] ALDAS Project File

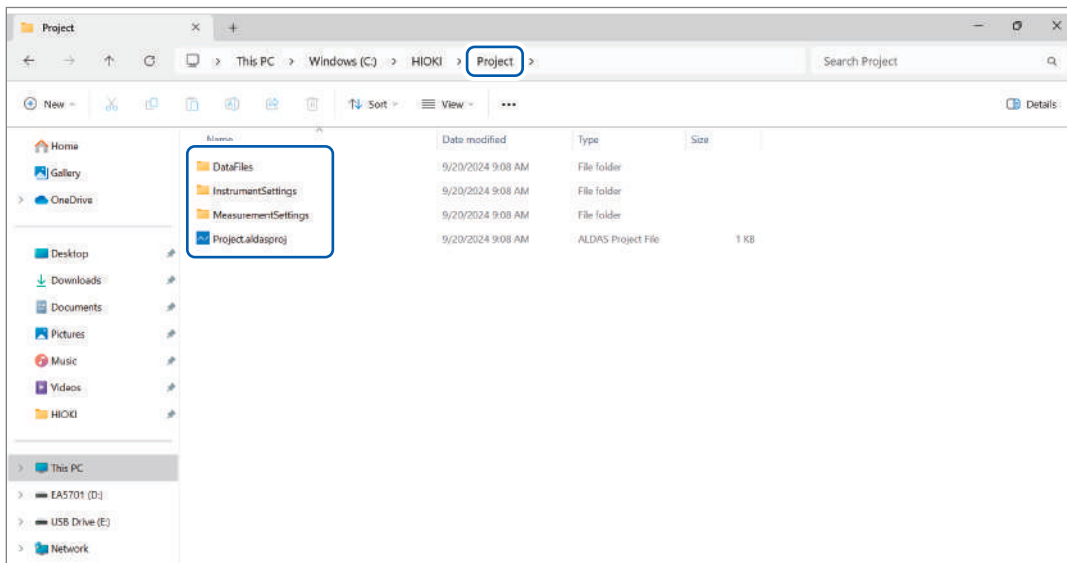

4 Making Measurements

4.1 Starting Measurement

- 1 Click the Measurement settings ([MEASURE]) tab.

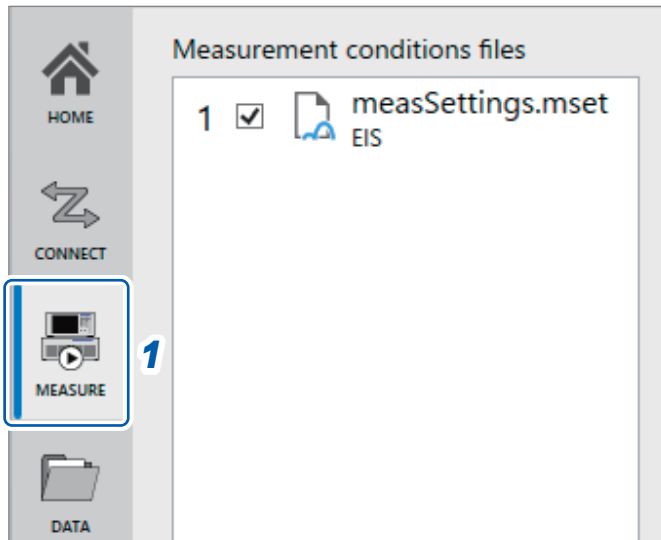

- 2 Click [Start].

Measurement will start using the set conditions.

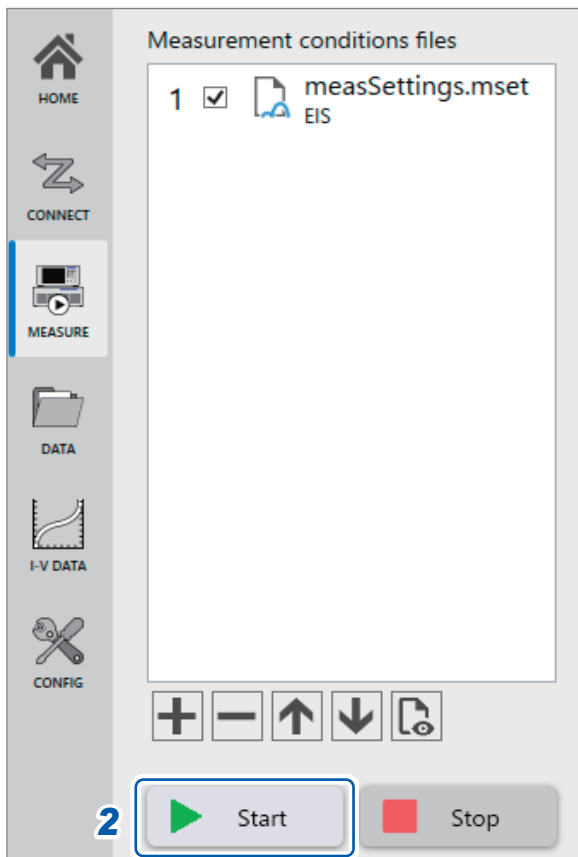

Starting Measurement

The main window will automatically switch to the Measurement data (**[DATA]**) tab. Measured data will automatically be added to the graph. In addition, measured data will be sequentially saved in CSV format in the **[DataFiles]** folder in the project folder. Refer to “3.6 Measurement Project Files and Folders” (p.57) for more details.

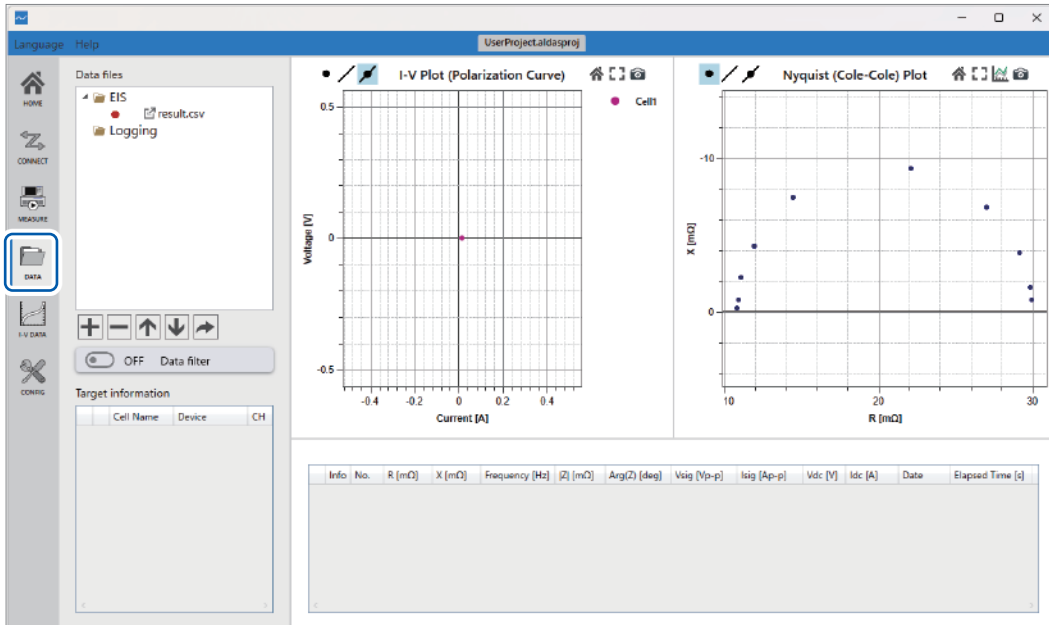

4.2 Checking Conditions During Measurement

To view the measurement progress, open the **[MEASURE]** tab and find it under **[Measurement status]** in the side menu.

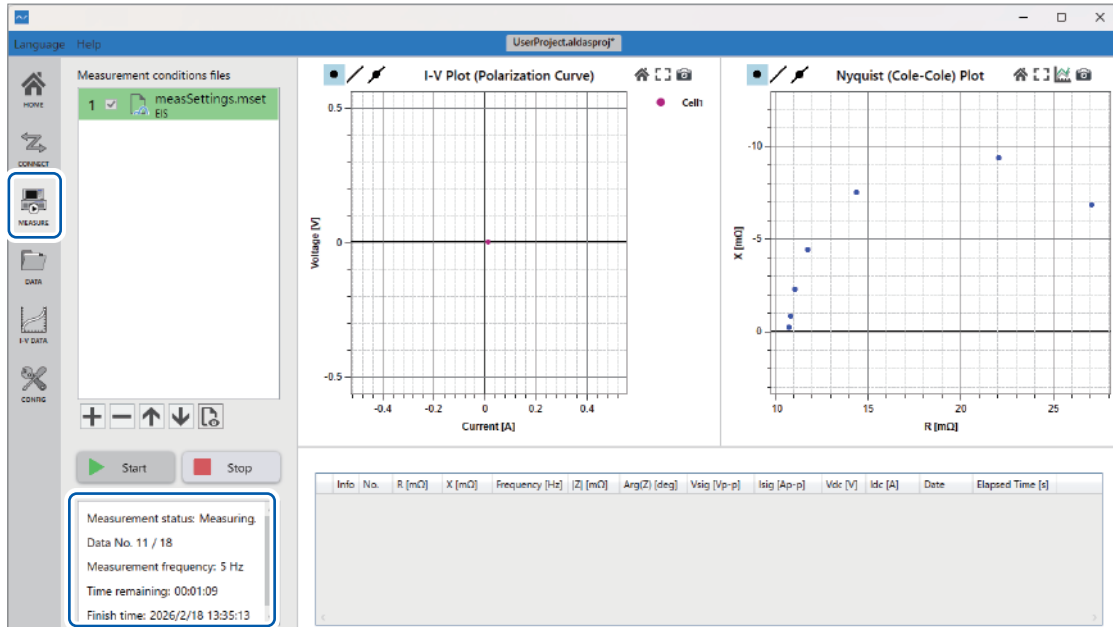

4.3 Stopping Measurement

Measurement will stop automatically once the final data point for the measurement condition file is acquired.

To stop the measurement in progress, follow the procedure below:

- 1 Click the Measurement settings ([MEASURE]) tab.
- 2 Click [Stop], and the top menu blue bar will disappear and restore to default view.

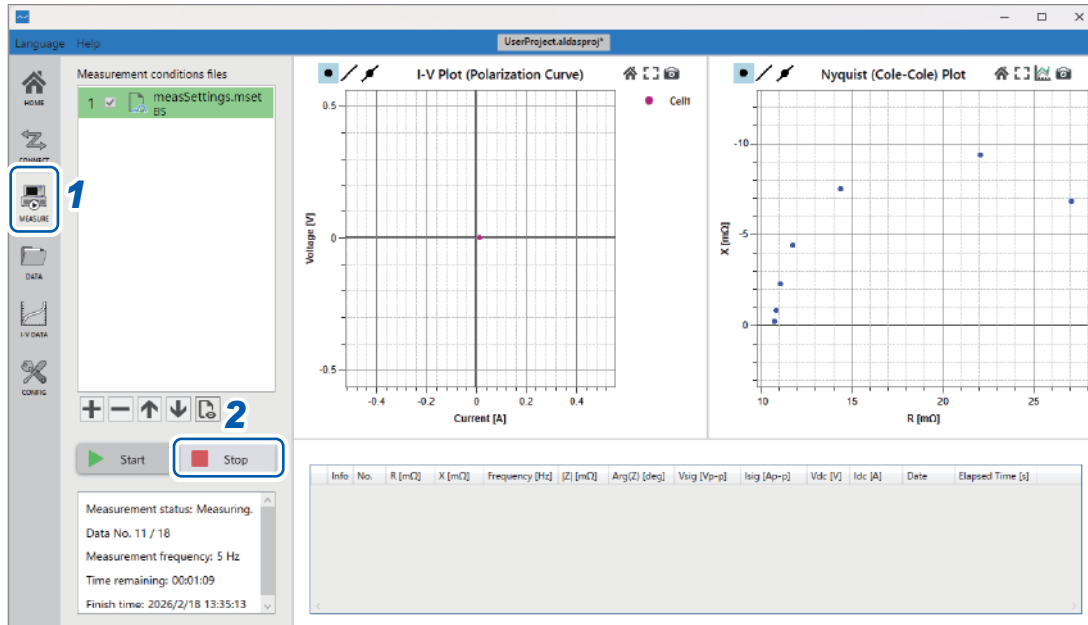

4.4 Measuring continuously (When There Are Multiple Measurement Conditions)

1 Click the Measurement settings ([MEASURE]) tab.

2 Edit the list of the [Measurement conditions files].

If multiple measurement conditions are listed in the [Measurement conditions files], the measurements are conducted in order from top to bottom for the conditions with checked boxes.

For more information about the use of the measurement condition files, see “7.2 Manipulating Measurement Conditions Files” (p.85).

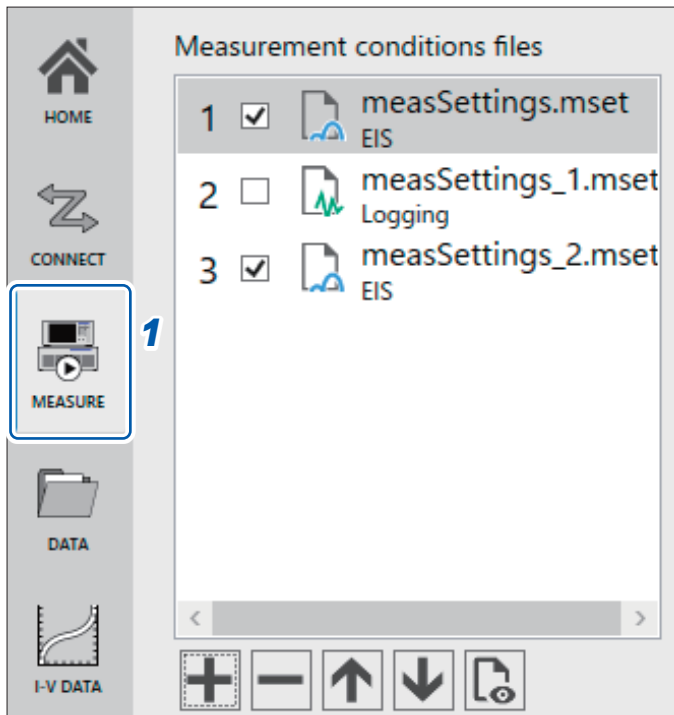

5

Checking Impedance Measurement Results

5.1 Viewing Data Files

1 Click the Measurement data ([DATA]) tab.

2 Select the data file you wish to view under [Data files].

There are two categories of data file: [EIS] and [Logging]. The impedance graph will change according to the types of data category file selected.

Information for each measured channels will be displayed under [Target information].

3 Select a target from [Target information].

Measurement data for the selected channel will be displayed in the data table at the bottom right of the window. You can use the table to check impedance and other measured values for each frequency.

The next page displays the detailed information for each item in the data table.

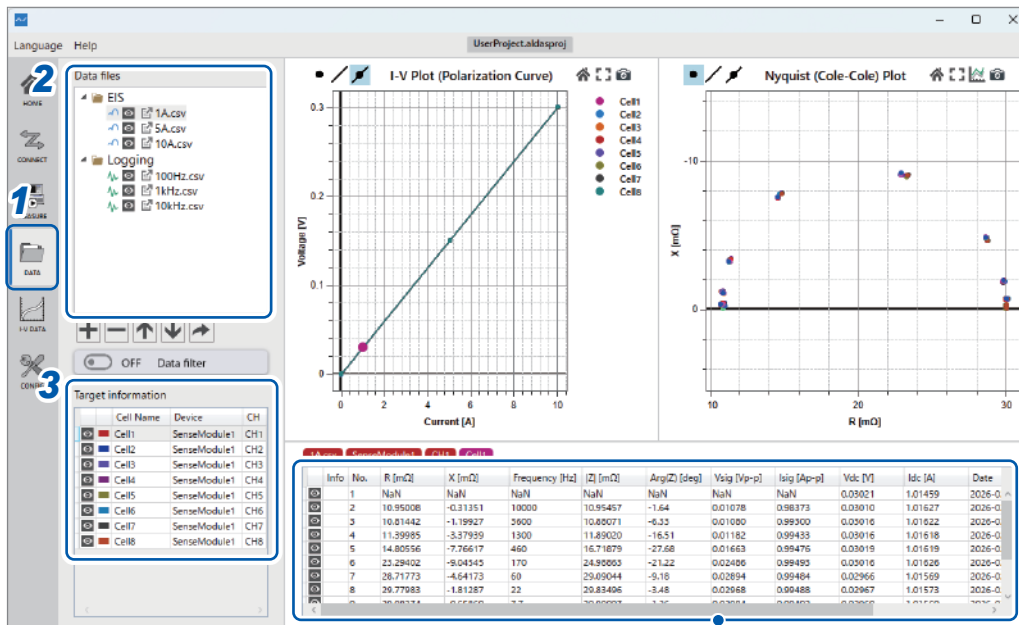

Data table

Data table explanation

1	2	3	4	5	6	7	8	9	10
Info	No.	R [mΩ]	X [mΩ]	Frequency [Hz]	Z [mΩ]	Arg(Z) [deg]	Vsig [Vp-p]	Isig [Ap-p]	
<input checked="" type="checkbox"/>	1	30.46791	-0.96405	10	30.48315	-1.81	0.30313	9.94423	
<input checked="" type="checkbox"/>	2	30.29769	-2.07850	22	30.36890	-3.92	0.30158	9.93047	
<input checked="" type="checkbox"/>	3	29.71325	-4.17966	46	30.00578	-8.01	0.29634	9.87605	
<input checked="" type="checkbox"/>	4	27.46922	-8.17431	100	28.65968	-16.57	0.27687	9.66078	

11	12	13	14
Date	Elapsed Time [s]	Vdc [V]	Idc [A]
2024-09-18 09:59:01	7.3	0.611	19.959
2024-09-18 09:59:08	14.5	0.611	19.958
2024-09-18 09:59:15	21.7	0.611	19.957
2024-09-18 09:59:23	25.1	0.611	19.957

No.	Item	Description
1		Selects whether to display the corresponding data in the graph. Data whose <input checked="" type="checkbox"/> mark is selected will be shown in the graph, while data whose <input type="checkbox"/> mark is not selected will not be shown in the graph.
2	Info	A warning icon will be displayed if the measured value is abnormal or if there is an error with the measurement conditions. Hover over the icon to see the reason. A warning example is listed below: <ul style="list-style-type: none"> • The measured value contains a non-numeric value (NaN). • The measured values contain infinity values (∞). • A small value of Vsig could lead to a significant measurement error. • Isig is very small compared to the set value. • The real part of the impedance has a negative value.
3	No.	This is the sequence number assigned to each data point as it is collected.
4	R [mΩ]	Real part of the impedance.
5	X [mΩ]	Imaginary part of the impedance.
6	Frequency [Hz]	Frequency at which impedance was measured.
7	Z [mΩ]	Absolute value of the impedance.
8	Arg(Z) [deg]	Phase angle of the impedance.
9	Vsig [Vp-p]	Peak-to-peak of signal's voltage amplitude at the impedance measurement frequency.
10	Isig [Ap-p]	Peak-to-peak of signal's current amplitude at the impedance measurement frequency.
11	Date	The time and date of data acquisition.
12	Elapsed Time [s]	Total time that has passed since the measurement begin.
13	Vdc [V]	Measured DC voltage.
14	Idc [A]	Measured DC current.

You can access the measurement conditions for each data file by clicking the measurement condition button beside the data file name.

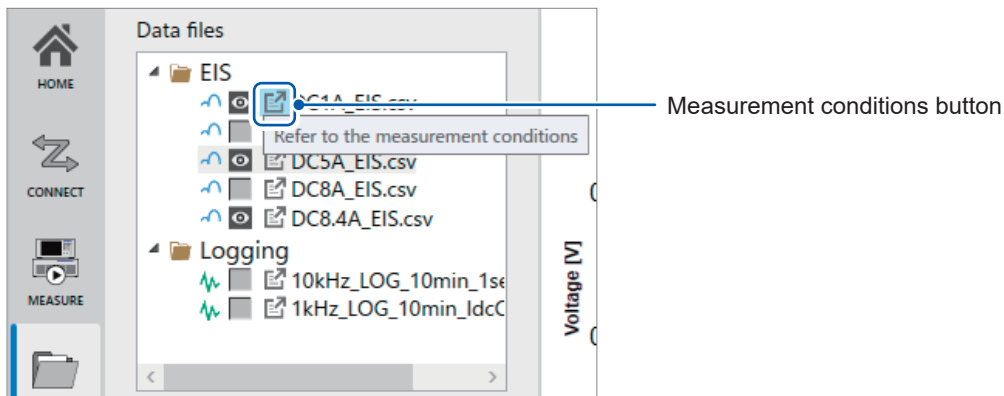

You can view each measurement condition setting by clicking on the left side tab. However, the contents of the measurement conditions cannot be edited.

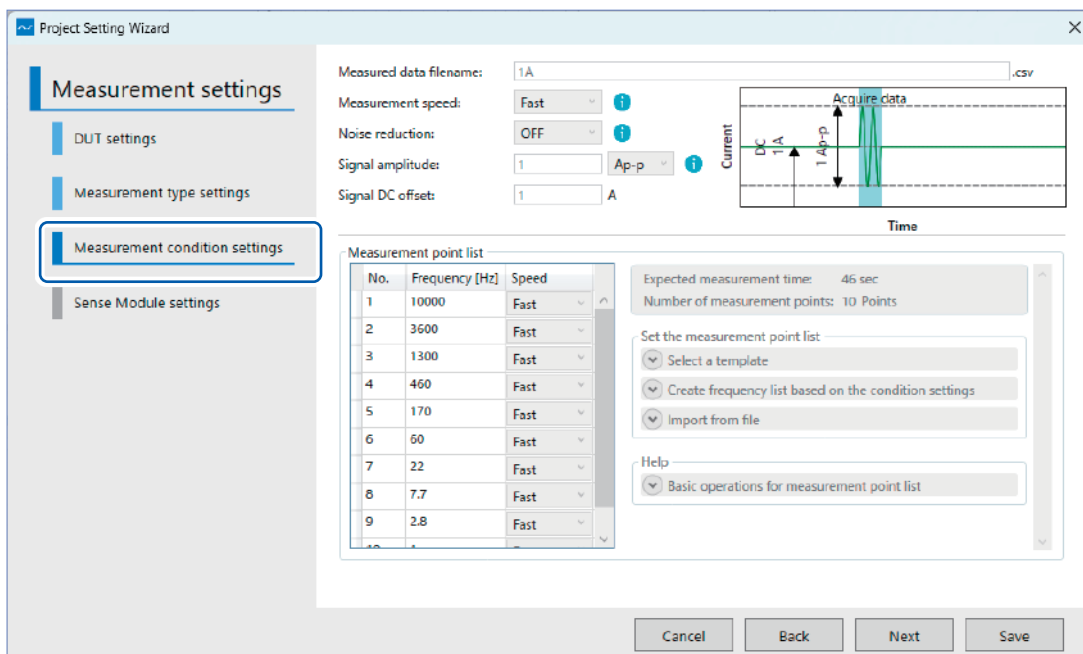

See “Setting the measurement target (DUT)” (p.46), “Setting the EIS Mode measurement method” (p.48), “Setting the Logging Mode (Fixed Frequency) measurement method” (p.50), “Configuring the Sense Module” (p.54), and “Review measurement settings” (p.55).

Clicking on the **[Measurement type settings]** tab displays a screen that includes a measurement condition memo text box.

This part allows you to enter a memo during measurement and save it together with the measurement data file.

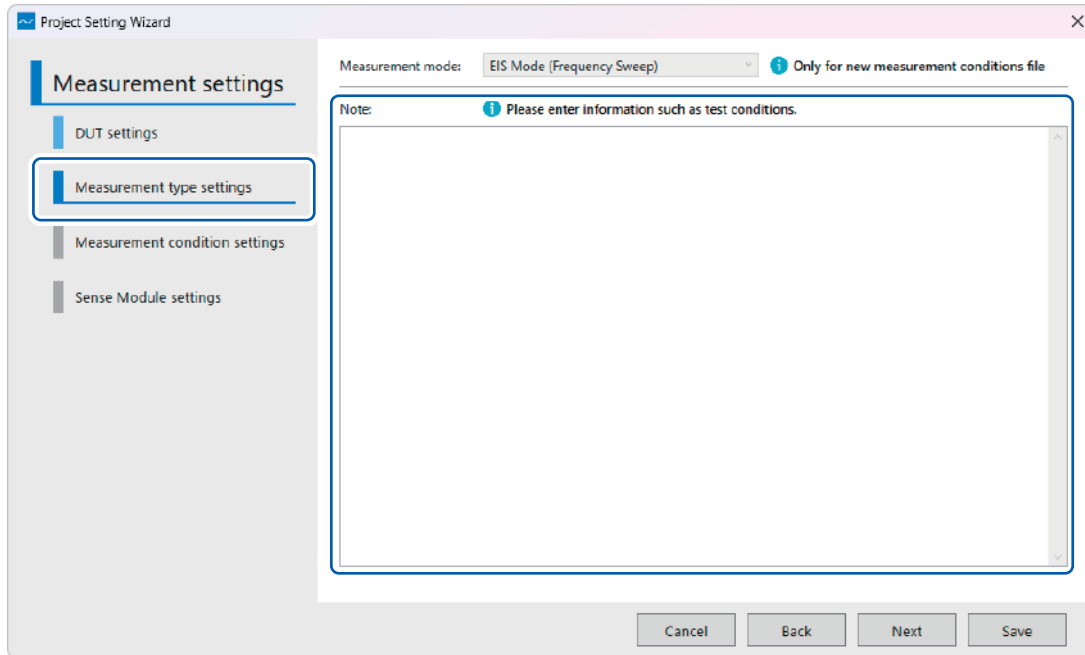

5.2 Changing the Graph's Configuration Settings

- 1** Click the Configuration settings ([CONFIG]) tab.

Graph's configuration setting will be displayed.

- 2** Change the impedance graph's configuration settings.

If you selected the [EIS] category data file:

If you selected the [Logging] category data file:

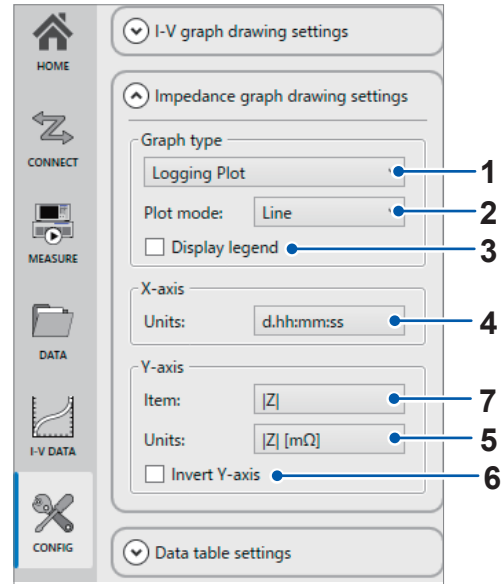
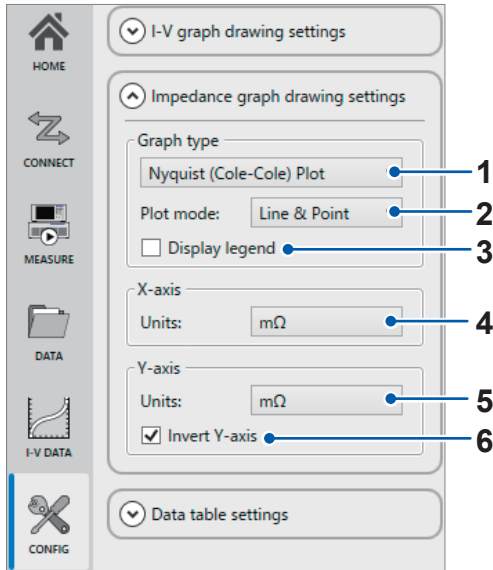

No.	Item	Description
1	Graph type	These are the graph types you can select for each respective category. For [EIS] category: <ul style="list-style-type: none"> • Nyquist (Cole-Cole) Plot • Bode Plot For [Logging] category: <ul style="list-style-type: none"> • Logging Plot
2	Plot mode	You can set the plot mode to Point, Line, or Line & Point.
3	Display legend	The graph legend can be displayed or hidden.
4	X-axis Units	You can select the unit prefix for the X-axis to change the scale of the graph.
5	Y-axis Units	You can select the unit prefix for the Y-axis to change the scale of the graph.
6	Invert Y-axis	Positive and negative directions for the Y-axis can be inverted for better visualization purposes.
7	Y-axis Item	You can change and select the Y-axis item from the drop-down menu depending on the graph types.

5.3 Manipulating Data Filters

By using the data filter function, you can search measured data for data that satisfies certain conditions.

1 Click the Measurement data ([DATA]) tab.

2 Click [Data filter].

The data selection window will be displayed.

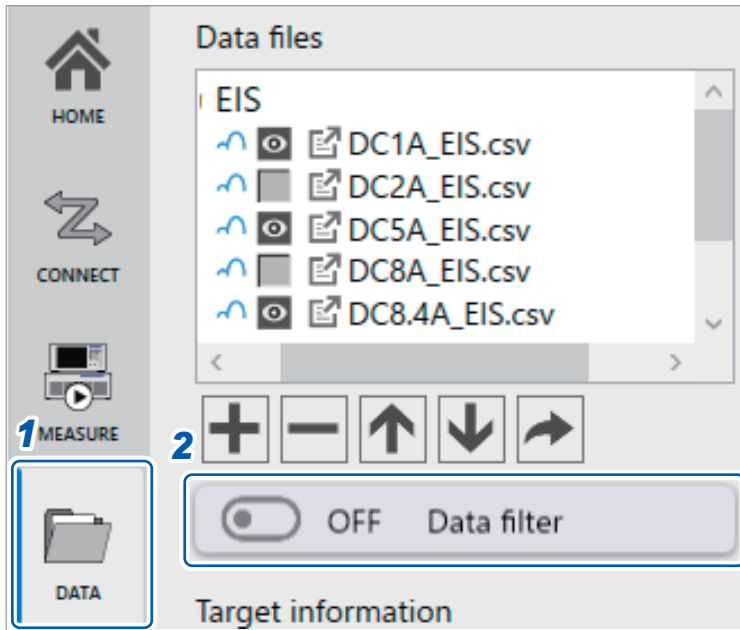

- 3 Select **[Data type]**.
- 4 Select detailed search conditions and enter a keyword or value.
Selecting multiple parameters will apply an AND condition.
- 5 Click **[OK]**.

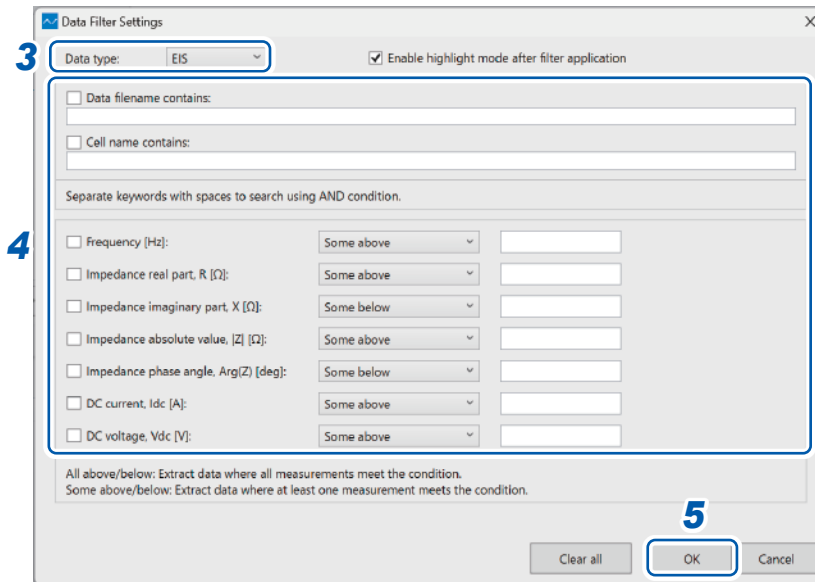

Measurement targets that satisfy the specified conditions will be displayed in the **[Target information]** table. If the **[Enable highlight mode after filter application]** checkbox is selected, only the measurement targets that match the filter will be highlighted and displayed in the graph.

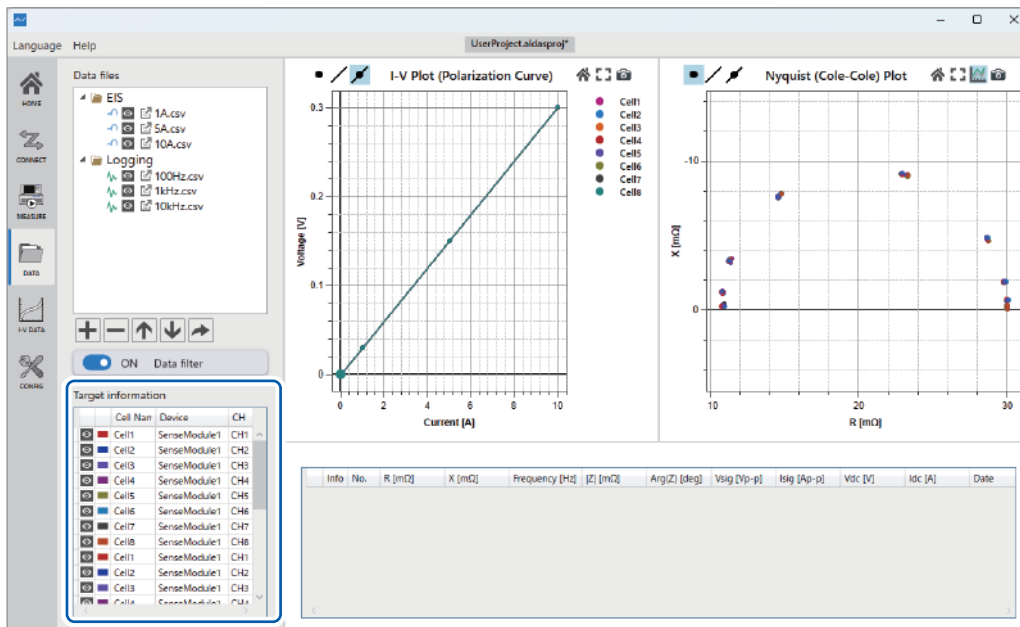

6

I-V Graph Function

This software generates an I-V graph based on the measured DC current and voltage DC values. The I-V graph is displayed alongside the impedance graph for easy comparison. You can also generate an IR-free graph by entering the cell's ohmic resistance in the cell information.

6.1 Displaying I-V Data

1 Click the I-V data ([I-V DATA]) tab.

2 Select the [Display I-V graph] checkbox.

You can display or hide the graph by selecting or deselecting the checkbox.

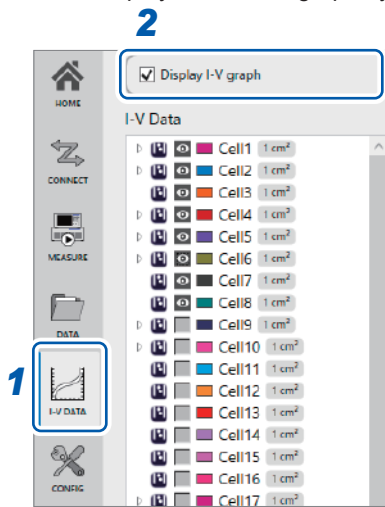

The I-V graph is displayed on the left side of the impedance graph.

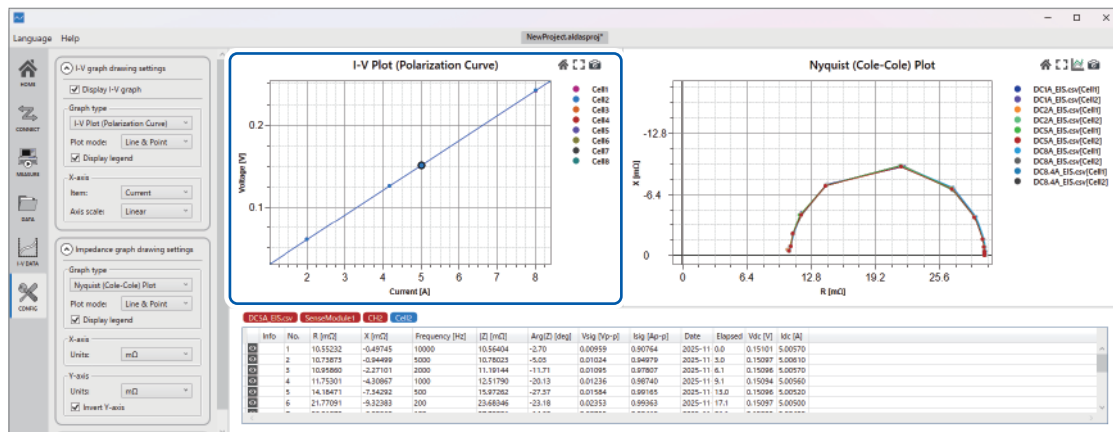

6.2 Changing the I-V Graph Settings

- 1** Click the Configuration settings ([CONFIG]) tab.
- 2** Change [I-V graph drawing settings].

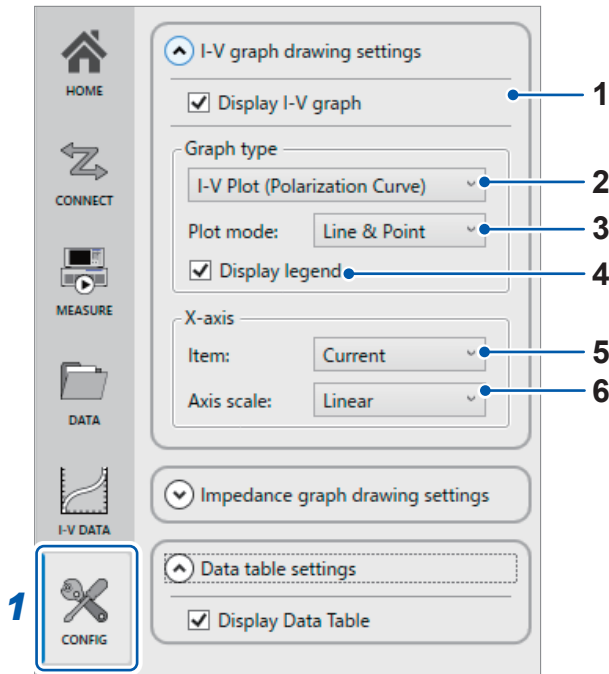

No.	Item	Description
1	Display I-V graph	You can show or hide the I-V graph.
2	Graph type	You can select from the following graph types: <ul style="list-style-type: none"> • I-V Plot • IR-free Plot • I-Power Plot • I-Impedance Plot
3	Plot mode	You can set the plot mode to Point, Line, or Line & Point.
4	Display legend	The graph legend can be displayed or hidden.
5	X-axis Item	You can change the X-axis parameter either Current or Current Density.
6	X-axis Axis scale	You can select either linear or logarithmic scale for the X-axis.

IR-free Plot

Plots the values calculated using the following formula and the user-specified ohmic resistance value as the [IR-free Voltage] value on the vertical axis.

$$\text{IR-free Voltage} = V_{dc} - R_{ohm} \times I_{dc}$$

V_{dc}: DC voltage of the measurement target

I_{dc}: DC current of the measurement target

R_{ohm}: Ohmic resistance specified by the user in cell information

I-Power Plot

Plots the values calculated using the following formula from the measurement data as the **[Power]** value on the vertical axis.

$$\text{Power} = V_{dc} \times I_{dc}$$

V_{dc}: DC voltage from the measurement data for the corresponding channel

I_{dc}: DC current from the measurement data for the corresponding channel

I-Impedance Plot

Plots the following measured values as the **[R_{hf}]** or **[R_{lf}]** value on the vertical axis:

You can change these values with the operations in “6.3 Editing I-V Data” (p.76).

R_{hf}: Impedance real part at the highest frequency in the measurement data for the corresponding channel

R_{lf}: Impedance real part at the lowest frequency in the measurement data for the corresponding channel

6.3 Editing I-V Data

Editing Cell Information

- 1** Click the I-V data ([I-V DATA]) tab.
- 2** Right-click on the cell information you wish to edit in the [I-V Data] list, and then select [Edit cell information].

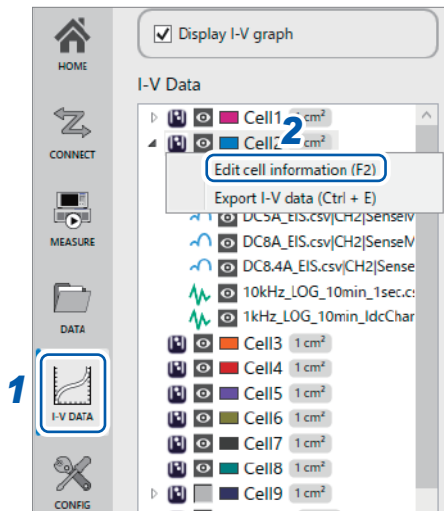

The cell information editing window will be displayed.
 The cell information set in “Setting the measurement target (DUT)” (p.46) is displayed in this window.

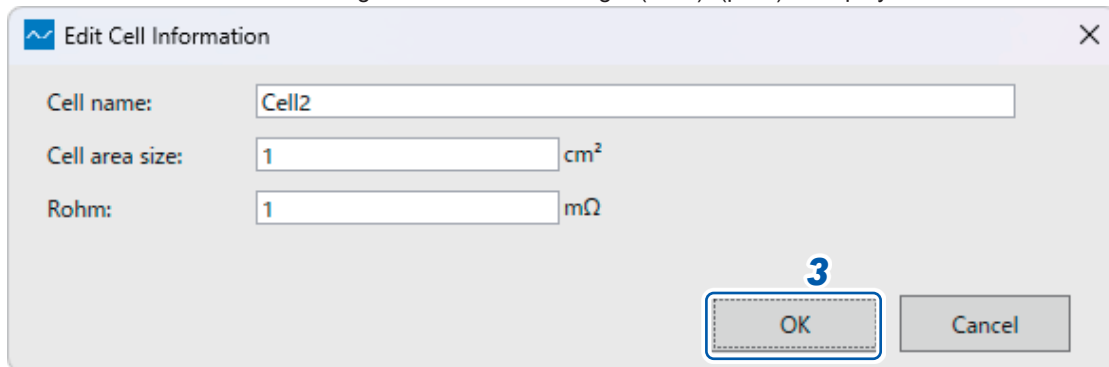

Cell name	You can change the name of the cell displayed on the graph legend and other locations.
Cell area size	By default, the cell size area size is set to “1”, but this value can be modified. This value is used to calculate current density. The default value “1” applies in the following cases: <ul style="list-style-type: none"> • The current density display is not selected • The parameters are unknown • The parameter of the cell area size, etc. is not applicable to the measurement target
Rohm	Specifies the cell’s ohmic resistance. This value is used to calculate IR-free plots. If no value is specified, the default value is 1 mΩ.

- 3** Edit the cell information and click [OK].
 The edited information will be applied to the display results.

Editing the I-V information

- 1 Click the I-V data ([I-V DATA]) tab.
- 2 Right-click on the I-V information you wish to edit in the [I-V Data] list, and then select [Edit I-V information].

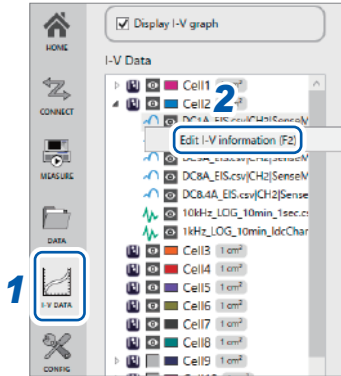

The I-V information editing window will be displayed.

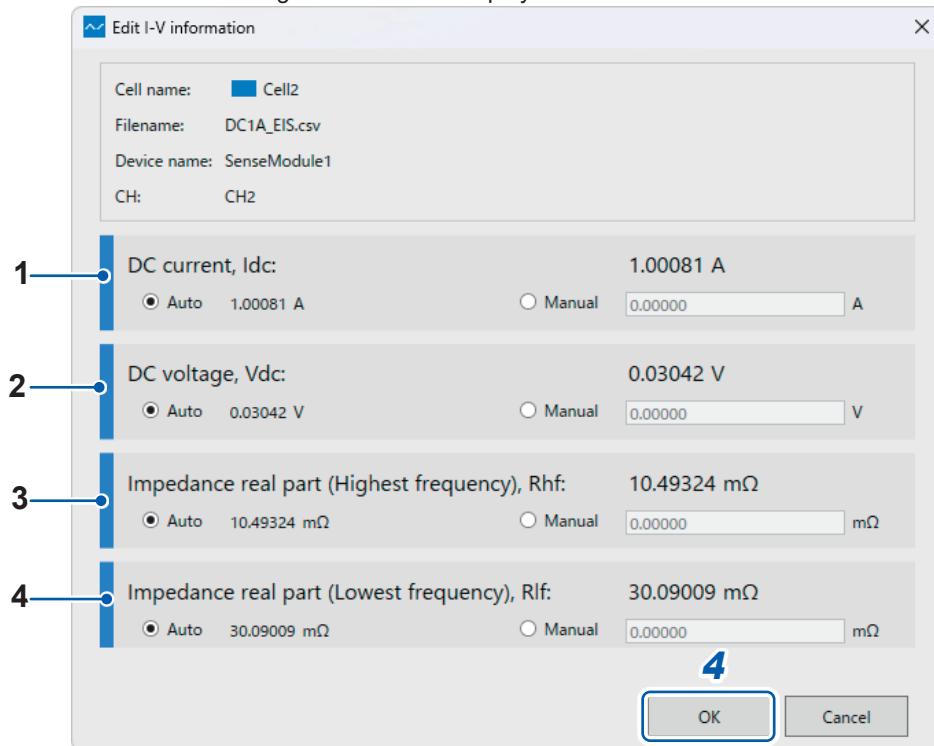

No.	Item	Description
1	DC current, Idc	Measured DC current of the measurement target. When set to [Auto] , the measurement uses the average DC current value in the corresponding impedance measurement data.
2	DC voltage, Vdc	Measured DC voltage of the measurement target. When set to [Auto] , the measurement uses the average DC voltage value in the corresponding impedance measurement data.
3	Impedance real part (Highest frequency), Rhf	This is the real part value of the impedance at the highest frequency, and this value is used to draw the I-Impedance Plot. When set to [Auto] , the measurement uses the real parts of the impedance data at the highest frequency in the respective channel.
4	Impedance real part (Lowest frequency), Rlf	This is the real part value of the impedance at the lowest frequency, and this value is used to draw the I-Impedance Plot. When set to [Auto] , the measurement uses the real parts of the impedance data at the lowest frequency in the respective channel.

3 Edit each item.

- **[Auto]** : automatically use the value calculated from the measurement.
- **[Manual]** : manually enter each value.

4 Click [OK].

The new data values setting will be applied to the results.

I-V information data edited in [Manual]

- Edited data in **[Manual]** will have small yellow pointer.
- I-V data that includes edited data in **[Manual]** will be displayed as a dashed line on the graph.

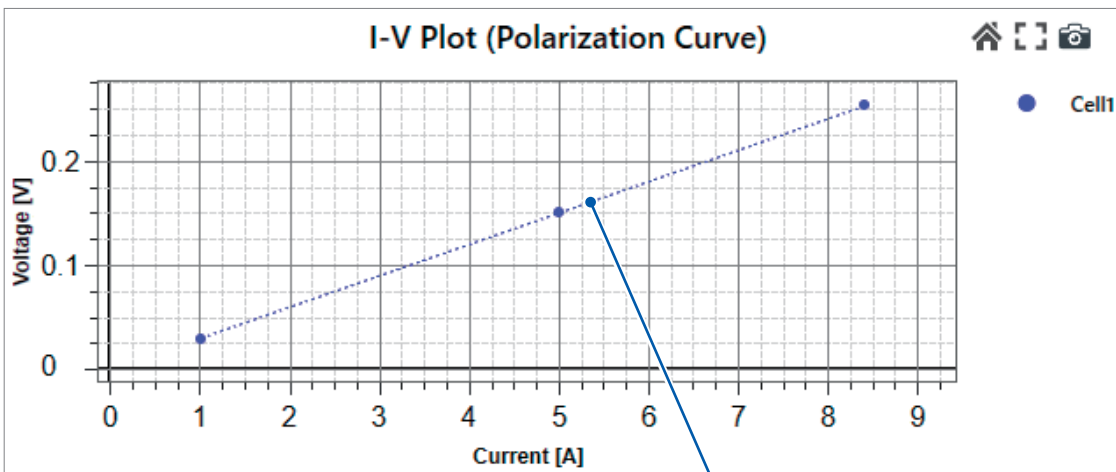
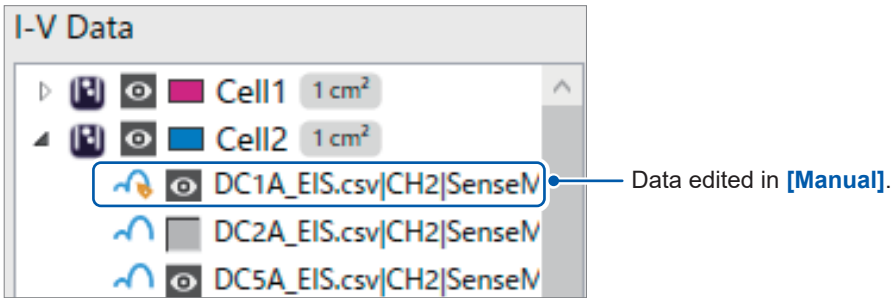

I-V data that includes edited data in **[Manual]**

6.4 Exporting the I-V Data to a File

- 1 Click the I-V data ([I-V DATA]) tab.
- 2 Right-click on the cell information of the [I-V Data] list, and then select [Export I-V data].

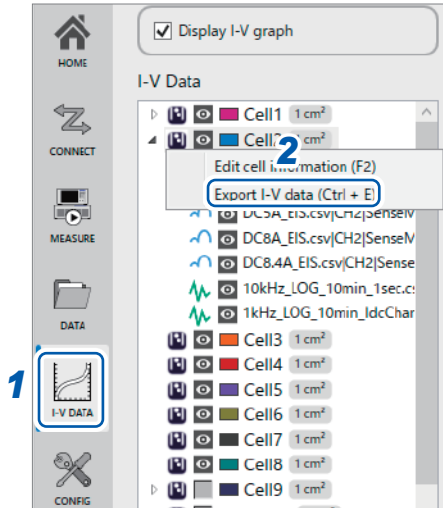

The Export I-V Data Options window will be displayed.

- 3 Specify the saving destination file path and file name for the I-V data, and then click [OK].

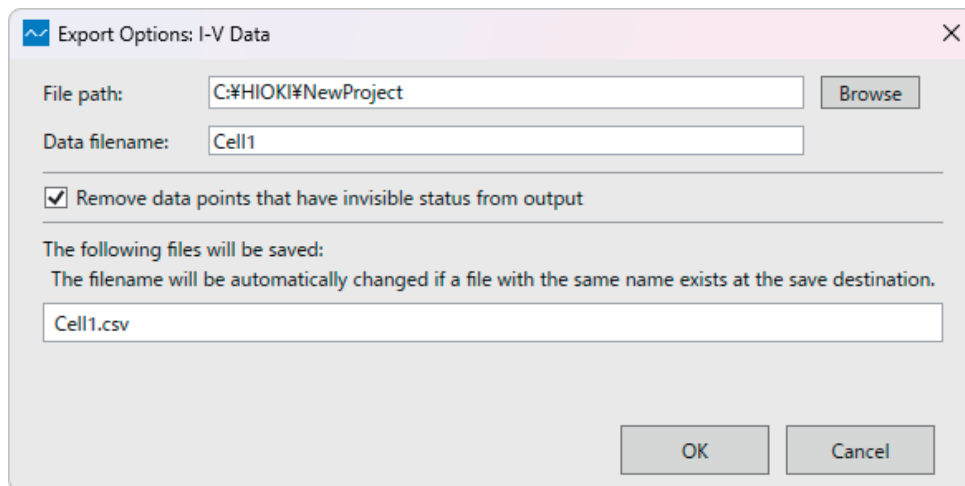

The I-V data will be output to a CSV file.
The format of the I-V data is listed below.

Item	Unit	Description
Idc	A	The DC current value set in [Edit I-V information] window is applied (Auto/Manual).
Vdc	V	The DC voltage value set in [Edit I-V information] window is applied (Auto/Manual).
Current Density	A/cm ²	The current density is calculated by dividing the DC current value by the cross-sectional area of the cell.
Rhf	Ω	The impedance real part value corresponding to the highest frequency in the data set from the [Edit I-V information] window.
Rlf	Ω	The impedance real part value corresponding to the lowest frequency in the data set from the [Edit I-V information] window.

7 PC application functions

7.1 Graph Common Operation

Setting for Displaying or Hiding the Measurement Data Graph

You can select or deselect the mark to show or hide data on the graph.

For data files

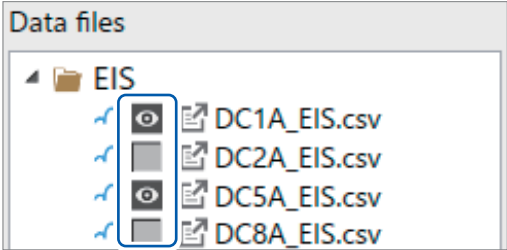

Changes the display for all data in the selected file.

For target information

	Cell Name	Device	CH
<input checked="" type="checkbox"/>	Cell1	SenseModule1	CH1
<input type="checkbox"/>	Cell2	SenseModule1	CH2
<input checked="" type="checkbox"/>	Cell4	SenseModule1	CH4
<input type="checkbox"/>	Cell5	SenseModule1	CH5

Changes the display for data from the selected channel.

For the data table

DC1A_EIS.csv SenseModule1 CH1 Cell1

	Info	No.	R [mΩ]	X [mΩ]	Frequency [Hz]
<input checked="" type="checkbox"/>		1	10.52955	-0.45660	10000
<input type="checkbox"/>		2	10.63287	-0.89698	5000
<input checked="" type="checkbox"/>		3	10.99809	-2.39475	2000
<input type="checkbox"/>		4	11.81300	-4.47578	1000

Changes the display for each selected data point.

Viewing Graphs

Viewing Graphs Using the Buttons

You can control the graph view with the buttons located at the top of the graph.



No.	Button label	Description
1	Point	Displays the graph using points only.
2	Line	Displays the graph using lines only.
3	Line&Point	Displays the graph using both points and lines.
4	Reset Axes	Resets the graph to its default view, automatically scaling it to fit the entire graph with zeros on both axes.
5	Auto Scale	Resets the graph to its default view, automatically scaling it to fit the entire graph.
6	Plot Highlight	Impedance graph only The graph line of the selected data will be shown in its original color, while other lines will be grayed out. This feature makes it easier to focus on a specific set of data when multiple data sets are displayed on the graph.
7	Snap Shot	Captures the graph display and saves it as an image.

Viewing graphs using the mouse

You can use these mouse action to explore and analyze the graph data more effectively.

Mouse operation	Description
Left-click and drag	Enlarges selected area.
Right-click and drag	Grab and move the graph.
Double left-click	Resets the graph to its default view, automatically scaling it to fit the entire graph.
Double right-click	If a point was selected, this action will cancel the data point selection on the graph.
Scroll wheel	Zoom in and out.

Displaying the Data Details on Graphs

1 Hover the mouse cursor to a point on the graph.

The measurement information at that data point will appear.

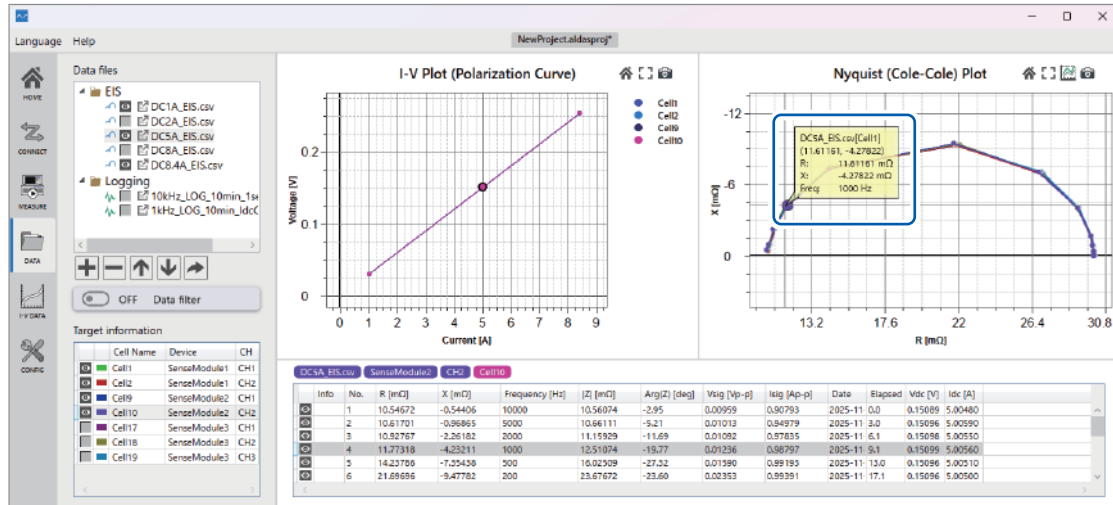

2 Click a point on the graph.

The selected point will be highlighted.

The data file, target information, and data table corresponding to the selected plot are displayed in each screen element. Additionally, the corresponding data is selected in the data table.

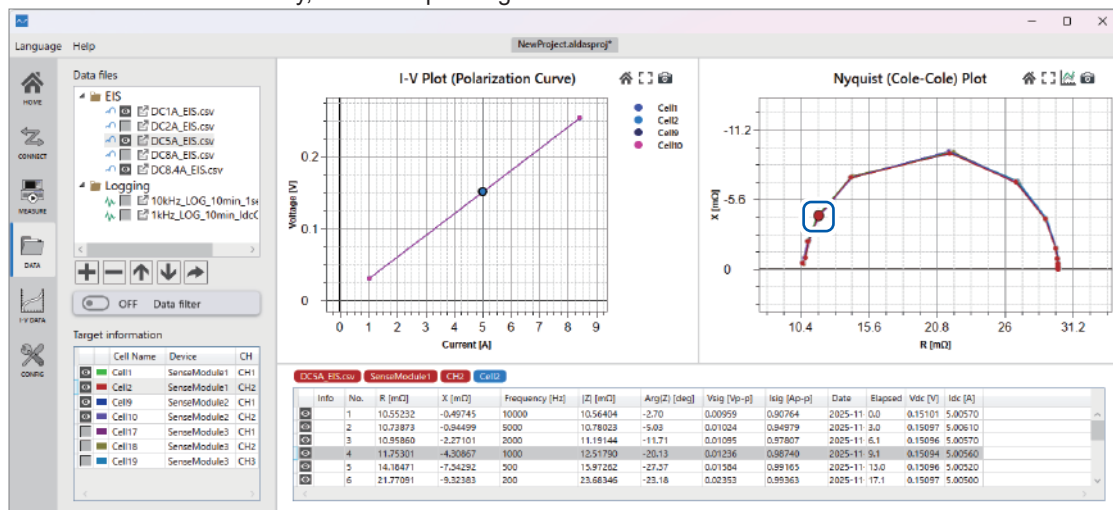

Setting the Graph Color and Marker Shape

- 1 Click the colored square button.

Target information			
	Cell Name	Device	CH
	Cell1	SenseModule1	CH1
	Cell2	SenseModule1	CH2
	Cell4	SenseModule1	CH4
	Cell5	SenseModule1	CH5

A **[Plot Options]** setting window will be displayed for the selected target information.

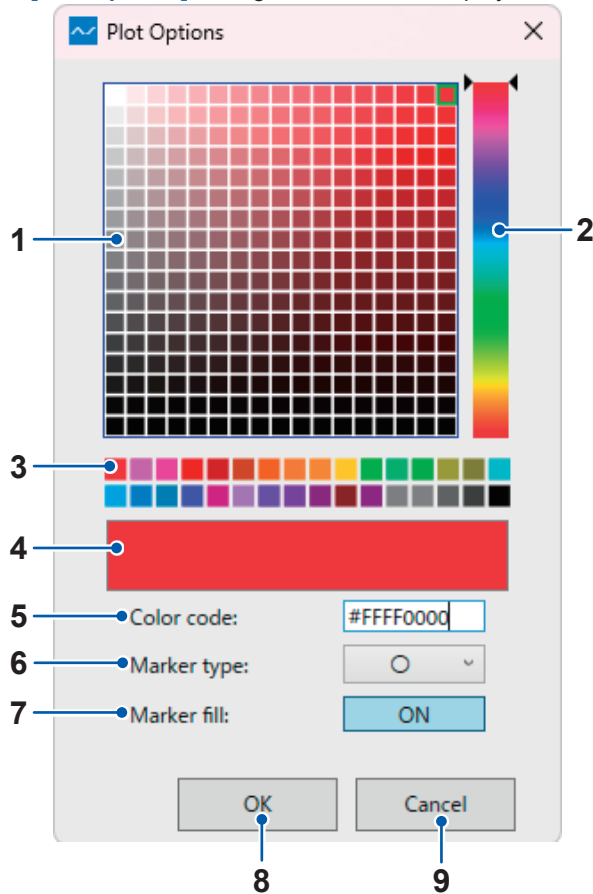

No.	Description
1	Select the graph color from a grid display.
2	Select a hue from a color bar.
3	Select the graph color from a number of color presets.
4	Displays the selected color.
5	Displays the color code for the selected color. You can also edit the color code directly.
6	Select the marker shape.
7	Enable or disable marker fill.
8	Click [OK] to apply the changes to the graph.
9	Discards changes and closes the window.

7.2 Manipulating Measurement Conditions Files

Adding, deleting, sorting, and previewing the measurement conditions

- 1 Click the Measurement settings ([MEASURE]) tab.
- 2 Use the files using the buttons at the bottom of the [Measurement conditions files] list.

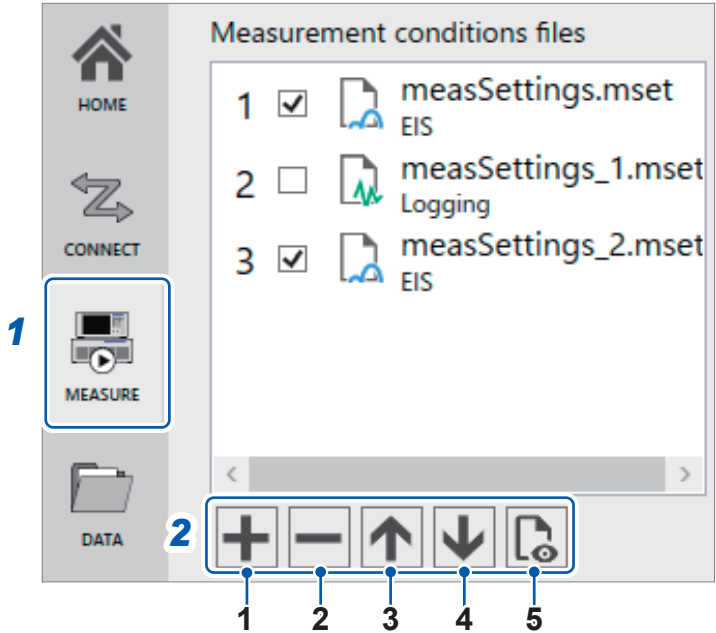

No.	Button label	Description
1	Add	Adds a new measurement condition.
2	Delete	Deletes the selected file.
3	Up	Moves the selected file up.
4	Down	Moves the selected file down.
5	Preview	Displays a preview of the measurement conditions.

Change the existing measurement conditions

You can change existing measurement conditions.

1 Click the Measurement settings ([MEASURE]) tab.

The [Measurement conditions files] loaded into the project will be displayed.

2 Double-click the measurement conditions file you wish to edit on the [Measurement conditions files] list.

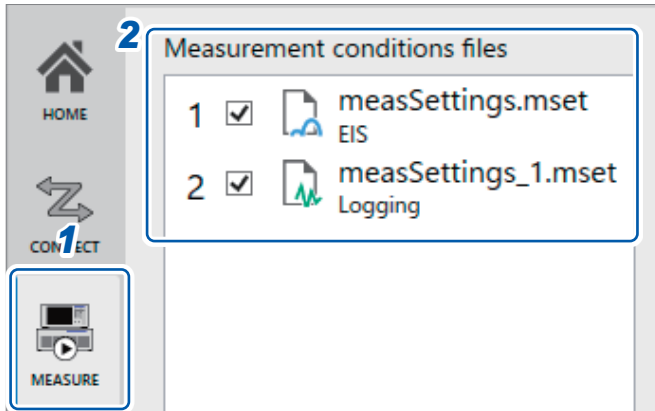

The measurement conditions setting window will be displayed.

3 Edit the parameter you wish to change and Click [Complete].

For more information about how to set new measurement conditions, see “3.4 Setting the Measurement Method” (p.46).

You can navigate the [Measurement settings] by selecting the tab available on the left-hand side of the [Project Settings] window.

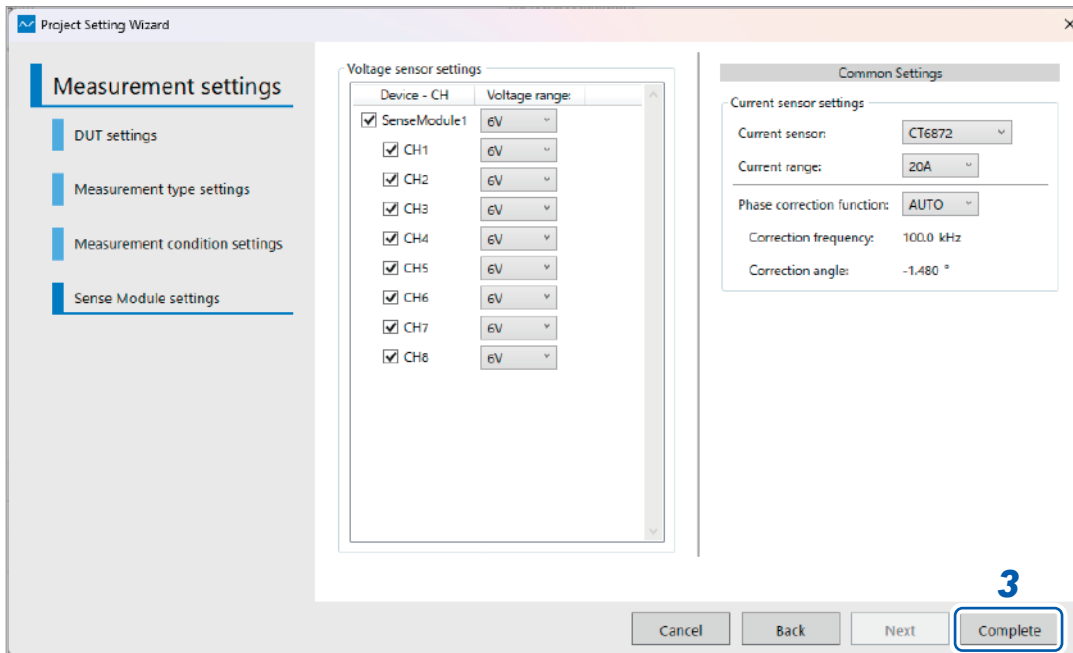

A dialog box confirming whether you wish to overwrite the settings will be displayed.

4 Click [Yes].

This will overwrite the measurement conditions with the new settings and save them.

Adding the existing measurement conditions

If you wish to copy and use measurement conditions created in another project, you can load them to this project [\[Measurement condition files\]](#) list.

Measurement conditions files are saved in the [\[MeasurementSettings\]](#) folder with “.mset” extension in the project folder.

- 1** Click the Measurement settings ([\[MEASURE\]](#)) tab.
- 2** Drag and drop the measurement conditions file you wish to load onto the [\[Measurement conditions files\]](#).

The measurement conditions will be loaded to the [\[Measurement conditions files\]](#) list.

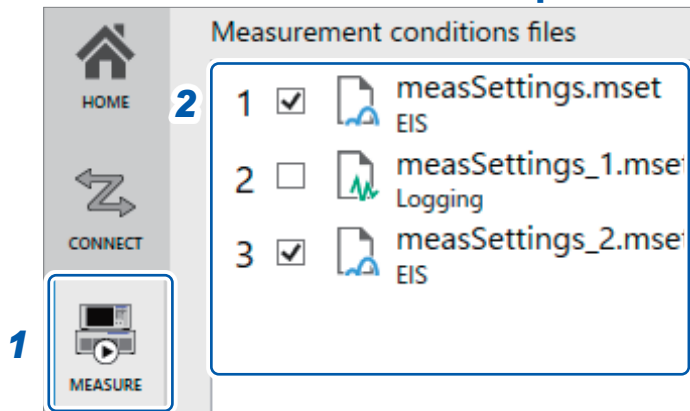

Changing the name of measurement conditions

You can change the filename used to store measurement conditions.

- 1 Right-click the file for which you wish to change the name of the [Measurement conditions files] list.**

The command menu will be displayed.

Alternatively, pressing the F2 key while a measurement conditions file is selected will display a screen allowing you to change the measurement conditions filename.

- 2 Click [Rename the measurement conditions file].**

A screen allowing you to change the measurement conditions filename will be displayed.

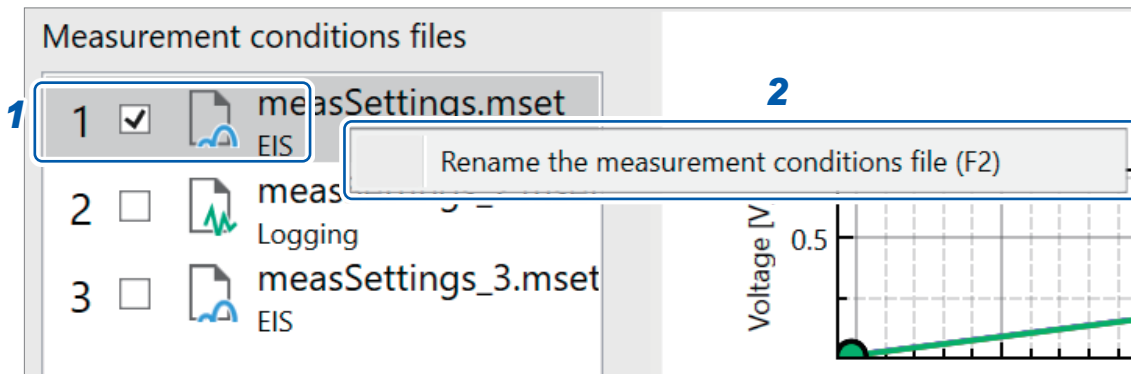

7.3 Manipulating Data Files

Loading a data file

The following files can be loaded: ALDAS format, Multi-plot format, and ZView (third-party company's trademark) format.

- ALDAS format: Data format for measurement results output by the ALDAS software
- Multi-plot format: Data format used by Multi-plot, Hioki's web application
- ZView format: Data format used by the Scribner's Zview equivalent circuit analysis software

There are a number of ways to load data files from an external source.

Adding a data file by dragging and dropping it

You can load a data file in a compatible format by dragging it and dropping it on the **[Data files]** list or on a graph.

For ALDAS format files, the graph category will be automatically recognized when the file is loaded. Files not in the ALDAS format can be loaded as **[EIS]** category files.

Adding data by right-clicking a category in the **[Data files]** list

You can add data using the menu shown when you right-click the mouse.

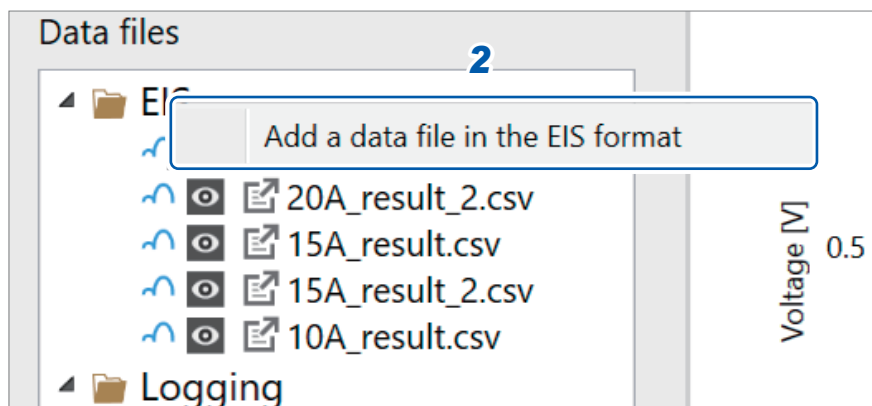

- 1** Select either the **[EIS]** or the **[Logging]** category in the **[Data files]** list and click the right mouse button.

The command menu will be displayed.

- 2** Click **[Add a data file in the xx format]**.

The data file selection window will be displayed.

- 3** Open the data file.

The data will be loaded using the selected category.

Adding data using the data file **[+]** button

You can add data using the menu shown when you click the **[+]** button underneath the **[Data files]** list.

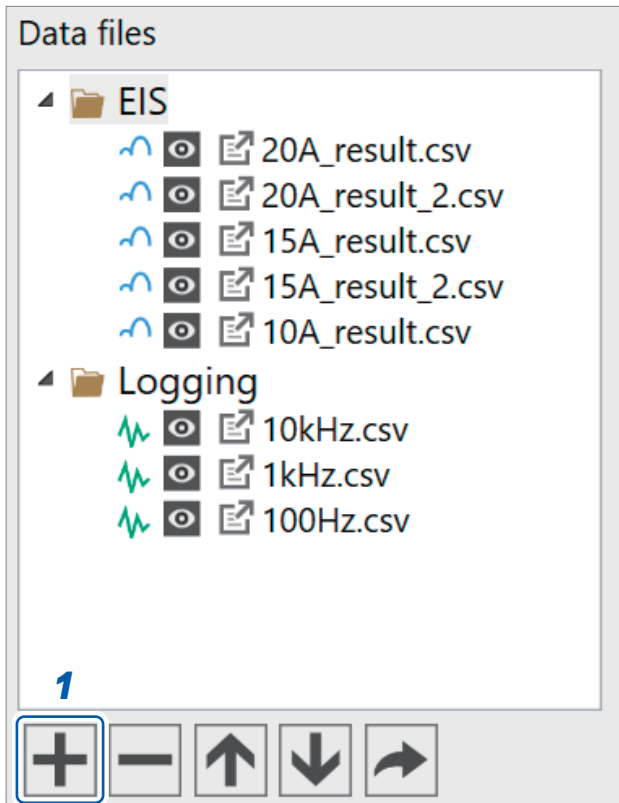

1 Click the **[+]** button underneath the **[Data files]** list.

The command menu will be displayed.

2 Select and click the desired operation.

- Add a data file in the EIS format
 - Add a data file in the logging format
- The data file selection window will be displayed.

3 Open the data file.

The data will be loaded using the selected category.

Loading data measured in a different project (including measurement conditions)

Folders named **[Data filename_Archive]** are generated in the **[DataFiles]** folder in the project folder.

You can drag and drop **[.darchive]** files inside any folder onto the **[Data files]** list or graph of the present open project.

This allows you to load the data contained in the file, including a link to the measurement conditions at the time of measurement.

Changing a data file's name

The names of data files can be changed.

- 1** Right-click the file for which you wish to change the name of the [Data files] list.

The command menu will be displayed.

- 2** Click [Rename the data file].

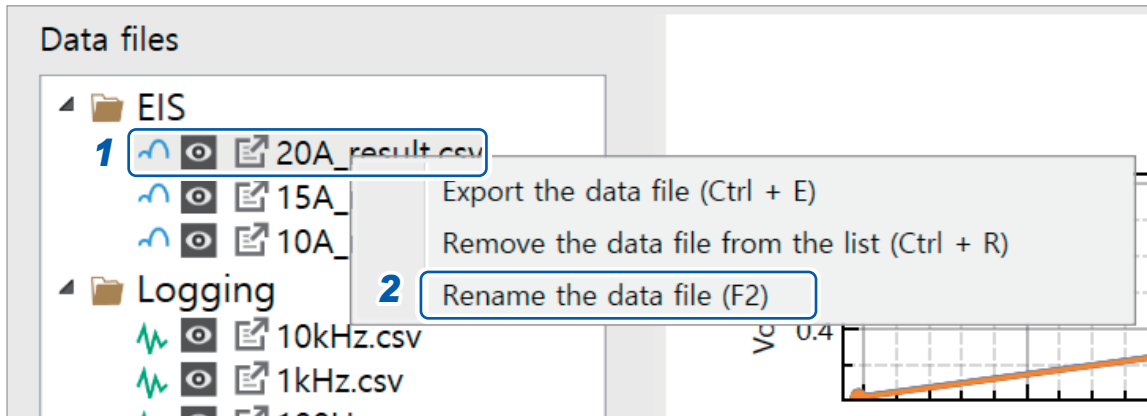

This command allows you to change the data file's name.

- 3** Enter a new filename and click [OK].

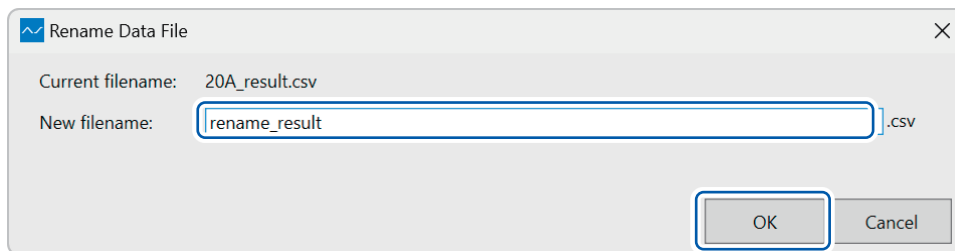

Removing a data file from the list

Deleting a file on the list

You can delete data files from the list.

1 Right-click the data file you wish to delete.

The command menu will be displayed.

2 Click **[Remove the data file from the list]**.

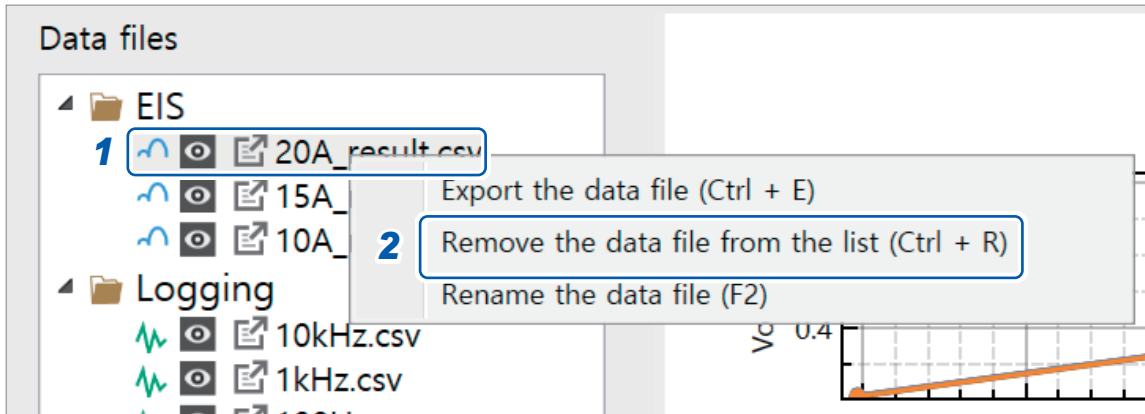

A confirmation dialog box will be displayed.

3 Click **[Yes]**.

The data file will be removed from the list.

The data file will be removed from the measurement project but will remain in the project folder's **[DataFiles]** folder.

Deleting a file using the menu

You can delete a data file using the command menu.

- 1** Select the data file you wish to delete.
- 2** Click the [-] button underneath the [Data files].
The command menu will be displayed.
- 3** Click [Remove the selected data file from the list].

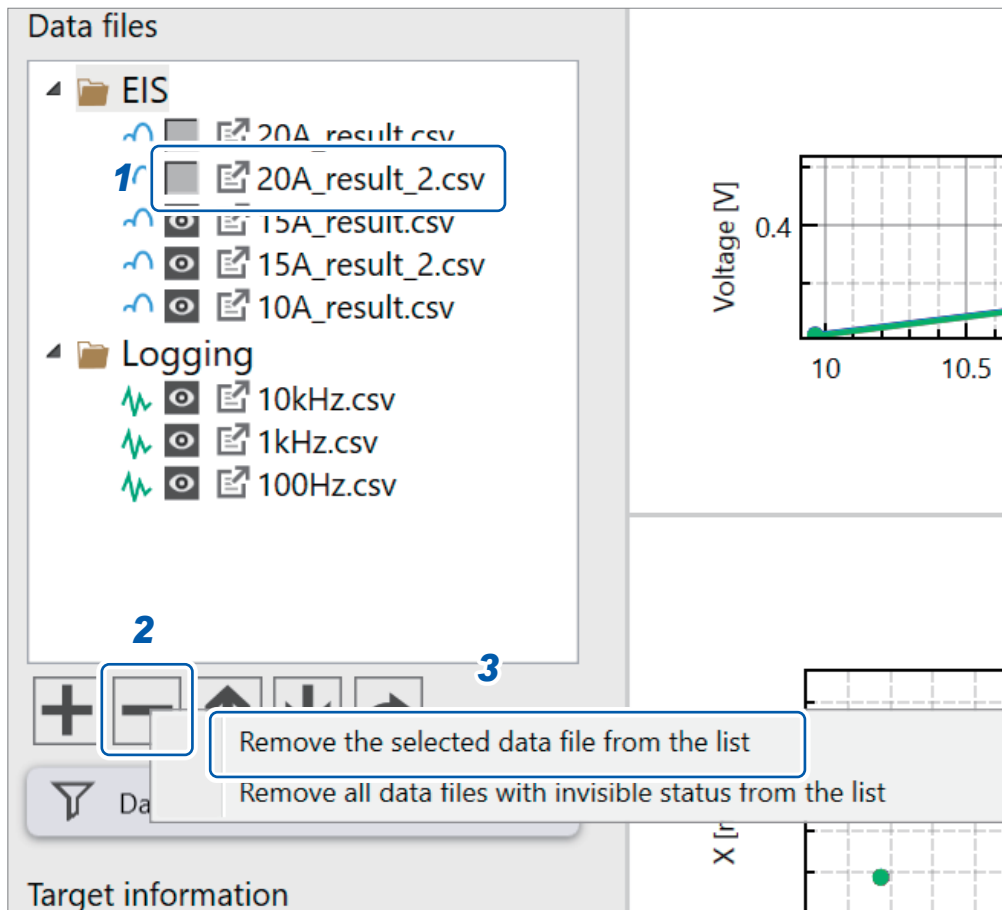

A confirmation dialog box will be displayed.

- 4** Click [Yes].
The data file will be removed from the list.

Exporting data files

1 Rick-click the data file you wish to export in a different file format.

The command menu will be displayed.

2 Click [Export the data file].

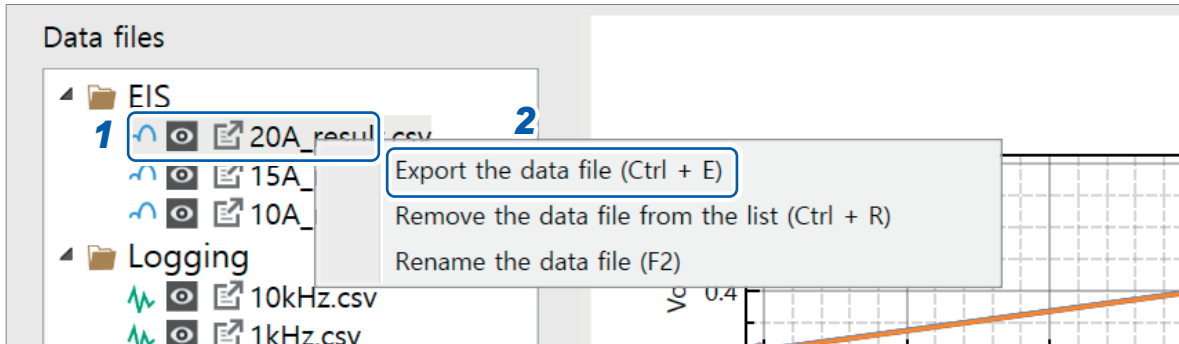

The data file export window will be displayed.

The following export options can be configured:

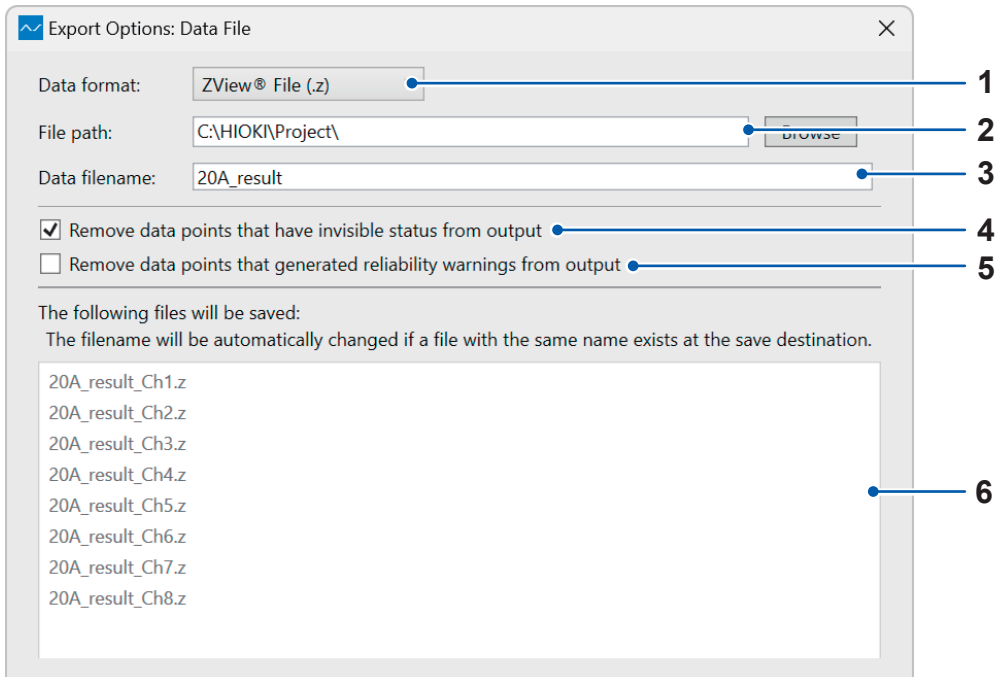

No.	Item	Description
1	Data format	You can choose ZView format [ZView File(.Z)] or Multi-plot format [Multi-plot File(.csv)] as the format in which to save the data file.
2	File path	Specifies the folder in which to save the file.
3	Data filename	Specifies the new data file name.
4	Remove data points that have invisible status from output	In Data table, removes data with no  mark from the output file.
5	Remove data points that generated reliability warnings from output	In Data table, removes data for which a warning icon is shown in [Info] from the output file.
6	The following files will be saved	Displays a list of data file names that will be saved.

The ALDAS data format

[ChannelNo.] will be replaced by the channel number.

Example: For CH2, "R_SenseModule1_Ch2], etc.

EIS format

Item	Unit	Description
Date		The time and date of data acquisition.
ElapsedTime	s	Time elapsed since the start of measurement.
SetFrequency	Hz	Frequency set in the measurement conditions.
MeasuredFrequency_SenseModule1_Ch[ChannelNo.]	Hz	Indicates the frequency at which the impedance was measured.
R_SenseModule1_Ch[ChannelNo.]	Ω	Real part of the impedance.
X_SenseModule1_Ch[ChannelNo.]	Ω	Imaginary part of the impedance.
AbsZ_SenseModule1_Ch[ChannelNo.]	Ω	Absolute value of the impedance.
ArgZ_SenseModule1_Ch[ChannelNo.]	$^{\circ}$	Phase angle of the impedance.
Vsig_SenseModule1_Ch[ChannelNo.]	Vp-p	Peak-to-peak of signal's voltage amplitude at the impedance measurement frequency.
Isig_SenseModule1_Ch[ChannelNo.]	Ap-p	Peak-to-peak of signal's current amplitude at the impedance measurement frequency.
Vdc_SenseModule1_Ch[ChannelNo.]	V	Measured DC voltage.
Idc_SenseModule1_Ch[ChannelNo.]	A	Measured DC current.

Logging format

Item	Unit	Description
ElapsedTime	s	Indicates the time elapsed since the start of measurement.
Date		Indicates the time elapsed since the start of measurement.
SetFrequency	Hz	Indicates the frequency set in the measurement conditions.
MeasuredFrequency_SenseModule1_Ch[ChannelNo.]	Hz	Indicates the frequency at which the impedance was measured.
R_SenseModule1_Ch[ChannelNo.]	Ω	Indicates the real part of the impedance.
X_SenseModule1_Ch[ChannelNo.]	Ω	Indicates the imaginary part of the impedance.
AbsZ_SenseModule1_Ch[ChannelNo.]	Ω	Indicates the absolute value of the impedance.
ArgZ_SenseModule1_Ch[ChannelNo.]	$^{\circ}$	Indicates the phase angle of the impedance.
Vsig_SenseModule1_Ch[ChannelNo.]	Vp-p	Indicates the voltage amplitude at the impedance measurement frequency as a peak-to-peak value.
Isig_SenseModule1_Ch[ChannelNo.]	Ap-p	Indicates the current amplitude at the impedance measurement frequency as a peak-to-peak value.
Vdc_SenseModule1_Ch[ChannelNo.]	V	Indicates the DC voltage value.
Idc_SenseModule1_Ch[ChannelNo.]	A	Indicates the DC current value.

7.4 Checking the System Connection Status and Reconnection

The measurement condition cannot be set if the application fails to verify the connection to the system devices after starting the project. Please verify the connection using the following steps:

- 1 Open the Connection settings (**[CONNECT]**) tab and click the **[Connection status]** button.



- 2 To reconnect, click either the **[Connected]** or **[Not connected]** button.

A window for **[Instrument settings]** will be displayed.

Click either the **[Connected]** or **[Not connected]** button to reconnect with the system.

See “3.3 Connecting to the System Instruments” (p.44).

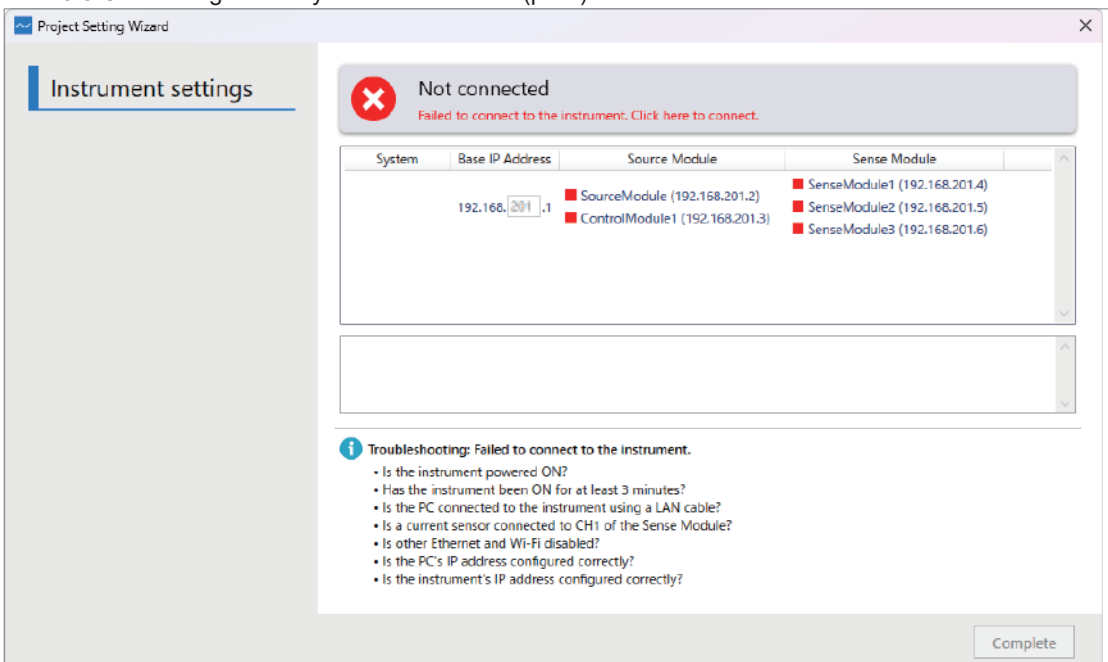

7.5 Manipulating Project Files

1 Use the project files in the [HOME] tab window.

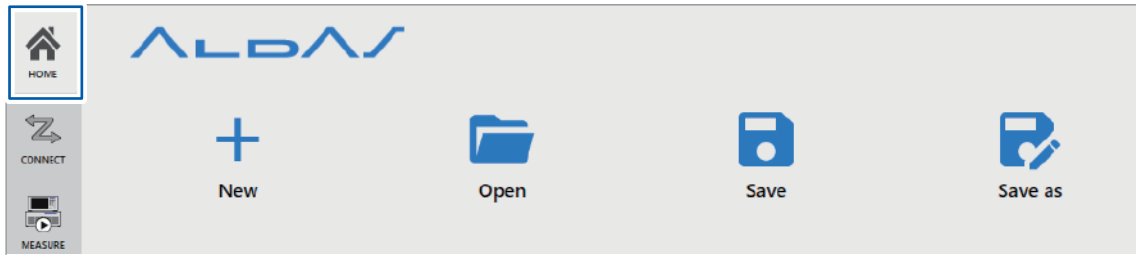

Button label	Description
New	Creates a new project. Perform settings according to “3 Configuring the PC Application” (p.41).
Open	Opens an existing project. Go to the directory of the project you wish to open in the file selection window, and then select the [Project name.aldasproj] file.
Save	Saves the status of the current project. Alternatively, use [ctrl]+[s] keys while the application is active will save the current project’s state. The following information is saved when a project is saved: <ul style="list-style-type: none"> • Hardware component information • Measurement conditions file list • Data file list • Data files and Measurement condition file links • Data display/hide attributes • Graph color and marker shape information • Data reliability information
Save as	You can change a project’s name as well as the directory in which it is stored. A folder with the same name as the project will be created in the specified directory, and the project file and related data files will be copied into it.

8

Ending Measurement

8.1 Exiting the PC application

1 Confirm that the measurement operation has ended.

If any changes were made to the project, please save the project before exiting. (The current project file will be overwritten.)

2 Click the close button on the window.

The PC application will close.

8.2 Turn off the system instruments

CAUTION



- **Ensure the measurement target's DC power supply is turned off and the system detects no voltage or current before shutting down the system.**

Failure to do so may result in system damage.

1 Turn off the measurement target's DC power supply.

2 Verify that there is no voltage or current detected from the measurement target by the Sense Module.

3 Press the Power button on the Sense Module to switch it off.

The Sense Module will turn off.

4 Switch off ("O") the Source Module main breaker.

The Source Module will turn off.

8.3 Disconnect the cables and current sensor from the measurement target

DANGER



- **Turn off measurement target's power supply before disconnecting the Sense Cable, Source Cable, and current sensor.**

Failure to do so could result in electric shock.

1 Disconnect the Sense Cable, current sensor, and Source Cable from the measurement target.

Disconnect the cables and current sensor from the measurement target

9.1 EA5701 ALDAS-mini

General specifications

(1) System architecture

ALDAS-mini	EA5701 ALDAS-mini (PC application)		
	EA5301 Sense Module		
	• Constituent units: 1		
	Display name	IP address	Subnet mask
	Sense Module 1	192.168.200.4	255.255.0.0
	EA5501 Source Module		
	• Constituent units: 1		
	Display name	IP address	Subnet mask
	Base IP Address	192.168.200.1	255.255.0.0
	Source Module	192.168.200.2	255.255.0.0
	Waveform Module	192.168.200.3	255.255.0.0

(2) PC application operating environment

Operating system	Windows11 Home/Pro/Enterprise/Enterprise LTSC
.NET library	Microsoft .NET Framework Runtime 4.8.1 or later
Processor	Intel® Core 5 or higher Clock speed of 2 GHz or higher and at least 2 physical cores
RAM	Minimum requirements: When the total number of channels is 8 or less: 8 GB or more When the total number of channels exceeds 8: 16 GB or more
Storage	Available space: At least 2 GB
Display	Resolution of at least 1920 × 1080 pixels
Interfaces	LAN (communications between the modules and PC) USB Type A (license authentication)
License certification type	USB dongle key (license key)
Recommended PC IP address	192.168.200.5 to 192.168.200.255
Valid PC IP address setting range	Valid IP address setting: 192.168.0.0 to 192.168.255.255 Invalid IP address setting (already reserved): 192.168.200.1 to 192.168.200.4 192.168.201.1 to 192.168.201.6 192.168.202.1 to 192.168.202.6
PC subnet mask settings	255.255.0.0

(3) Other

Accessories	See p.6 (EA5701 ALDAS-Mini (PC application)).
PC application supply media	USB flash drive

Functional specifications

(1) Impedance measurement

Impedance measurement frequency range	10 mHz to 100 kHz	
EIS Mode (Frequency Sweep)	Measures impedance at multiple user-specified frequencies.	
Logging Mode (Fixed Frequency)	Repeatedly measures impedance at one user-specified frequency. Total measurement time: 1 s to 180 days Logging interval: 1 s, 2 s, 5 s, 10 s, 30 s, 1 min., 2 min., 5 min., 10 min., 30 min., 1 hour Maximum number of repeating measurement points (per channel, per set of measurement conditions): 5000 points	
Impedance measurement method	Real part	$R = U_{sig} / I_{sig} * \cos\theta$
	Imaginary part	$X = U_{sig} / I_{sig} * \sin\theta$
	Symbol	R : Impedance real part [Ω] X : Impedance imaginary part [Ω] U_{sig} : Voltage p-p value [V] for the impedance measurement frequency component I_{sig} : Current p-p value [A] for the impedance measurement frequency component θ : θ Voltage and current phase difference [$^\circ$]
Impedance measurement data	ZView [®] (third-party company's trademark) files (.z) Multi-plot files (.csv) ALDAS files (.csv)	
ALDAS file output parameters	System architecture: ALDAS software version, ALDAS software license, Sense Module model name (serial number), current sensor model name Measurement conditions: Measurement mode, measurement speed, noise reduction, signal amplitude, signal DC offset, Sense Module voltage range, Sense Module current range Common to all measurement channels: Time and date, measurement elapsed time, frequencies set in measurement conditions For individual measurement channels: Frequencies measured, impedance real part, impedance imaginary part, impedance absolute value, impedance phase angle, voltage of impedance measurement frequency component, current of impedance measurement frequency component, DC voltage, DC current	

(2) Measurement condition settings

Measurement speed setting	Fast, Medium, Slow Length of average processing increases in the following order: Slow > Medium > Fast.	
Impedance measurement frequency resolution	Set frequency f [Hz]	Frequency resolution [Hz]
	$10000 \leq f \leq 100000$	1000
	$1000 \leq f < 10000$	100
	$100 \leq f < 1000$	10
	$10 \leq f < 100$	1
	$1 \leq f < 10$	0.1
	$0.1 \leq f < 1$	0.01
	$0.01 \leq f < 0.1$	0.001

(3) I-V characteristics measurement

I-V characteristics measurement function	When impedance measurement is performed, measures the DC current and DC voltage values and displays the DC current and DC voltage measured values when performing impedance under multiple conditions as I-V characteristics.	
I-V measurement method	DC current	Measures the DC current before signal superposition.
	DC voltage	Measures the DC voltage before signal superposition.

(4) Graph rendering

Impedance graph	Nyquist (Cole-Cole) Plot	Horizontal axis: Impedance real part Vertical axis: Impedance imaginary part
	Bode Plot	Horizontal axis: Frequency Vertical axis: Impedance real part, imaginary part, absolute value, phase angle, current p-p value for impedance measurement frequency component, voltage p-p value for impedance measurement frequency component, current value for DC component, voltage value for DC component (select one)
	Logging Plot	Horizontal axis: Measurement time Vertical axis: Impedance real part, imaginary part, absolute value, phase angle, current p-p value for impedance measurement frequency component, voltage p-p value for impedance measurement frequency component, current value for DC component, voltage value for DC component (select one)
I-V graph	I-V Plot (Polarization Curve)	Horizontal axis: DC current Vertical axis: DC voltage
	IR-free Plot	Horizontal axis: DC current Vertical axis: IR-free voltage $V_{IR-free} = V_{dc} - R_{ohm} * I_{dc}$ $V_{IR-free}: \text{ IR-free voltage}$ $V_{dc}: \text{ DC voltage}$ $I_{dc}: \text{ DC current}$ $R_{ohm}: \text{ Ohmic resistance (user-defined)}$
	I-Power Plot	Horizontal axis: DC current Vertical axis: DC power $P = I_{dc} * V_{dc}$ $P: \text{ DC power}$ $V_{dc}: \text{ DC voltage}$ $I_{dc}: \text{ DC current}$
	I-Impedance Plot	Horizontal axis: DC current Vertical axis: Maximum frequency resistance (<i>R_{hf}</i>) or minimum frequency resistance (<i>R_{lf}</i>) (select one) <i>R_{hf}</i> : Impedance real part at the highest frequency in the impedance measurement file <i>R_{lf}</i> : Impedance real part at the lowest frequency in the impedance measurement file
Impedance graph maximum number of render points	Depends on the RAM capacity of the PC. When RAM is 16.0 GB or less: 400,000 points When RAM exceeds 16.0 GB: 1,200,000 points	

(5) Alarm function

Sense Module error detection	Current range exceeded	If an input exceeding the current range setting is detected, signal superposition and measurement will stop.
	Voltage range exceeded	If an input exceeding the voltage range setting is detected, signal superposition and measurement will stop.
Source Module error detection	Overvoltage detection	If an overvoltage is detected at the Source Module's signal superposition terminals, signal superposition and measurement will stop.
	Overpower detection	If an overcurrent is detected at the Source Module's signal superposition terminals, signal superposition and measurement will stop.
	Network error detection	If communications between the PC and Source Module are interrupted for 20 seconds or more during measurement operation, signal superposition and measurement will stop.
	Overheat detection	If an overheat condition is detected inside the Source Module, signal superposition and measurement will stop.
	Wiring error detection	If a short or open condition is detected at the Source Module's signal superposition terminals, signal superposition and measurement will stop.
	Reverse connection detection	If a reverse voltage or reverse current is detected at the Source Module's signal superposition terminals, signal superposition and measurement will stop.

(6) Saving of settings data

Saved data	<ul style="list-style-type: none"> • Application settings Project-related files' relative save path, measurement data list, graph settings • Hardware settings Interface and model information for connected devices • Measurement condition settings Measurement frequency, measurement amplitude, hardware settings • Information added to data Graph render information, alert information
Data format	XML format

(7) Saving of measurement data

Saved data	Measurement time and date, elapsed time, set frequency, measurement frequency, impedance real part, impedance imaginary part, voltage of impedance measurement frequency component, current of impedance measurement frequency component, impedance absolute value, impedance phase angle, DC voltage, DC current
Data format	CSV format

9.2 EA5301 Sense Module

General specifications

Operating environment	Indoor use, pollution degree 2, altitude up to 2000 m (6562 ft.)
Operating temperature and humidity range	0°C to 40°C (32°F to 104°F), 80% RH or less (no condensation)
Storage temperature and humidity range	-10°C to 50°C (14°F to 122°F), 80% RH or less (no condensation)
Standards	Safety EN 61010 EMC EN 61326 Class A
Power supply	Grid power Rated supply voltage: AC100 V to 240 V (Assuming voltage fluctuation of $\pm 10\%$) Rated power-supply frequency: 50 Hz/60 Hz Anticipated transient overvoltage: 2500 V Maximum rated power: 150 VA for main unit only
Backup battery life	Lithium batteries: Approx. 10 years (reference value at 23°C) Time/setting conditions
Dimensions	Approx. 430W × 221H × 361D mm (16.9W × 8.7H × 14.2D in.) (excluding protruding parts)
Weight	Approx. 12.7 kg (28.0 lb.) (EA5301-08)
Product warranty duration	1 year
Accessories	See p.6 (EA5301 Sense Module).
Option	See p.7 (Cable for voltage measurement, Products for current measurement).

Input, output, measurement specifications

(1) Voltage and current measurement shared specifications

No. of input units	Max. 8 units
Sampling	15 MHz, 18 bit
Measurement frequency band	DC, 0.1 Hz to 5 MHz
Effective measurable range	1% to 100% of range

(2) Voltage measurement specifications

Number of input channels	1 channel (EA5301-01) 2 channels (EA5301-02) 3 channels (EA5301-03) 4 channels (EA5301-04) 5 channels (EA5301-05) 6 channels (EA5301-06) 7 channels (EA5301-07) 8 channels (EA5301-08)
Input terminal profile	Plug-in terminals (safety terminals)
Input type	Isolated, resistive potential divider
Range	6 V, 15 V, 30 V, 60 V
Crest factor	3 relative to voltage range ratings
Input resistance, input capacitance	4 M Ω \pm 20 k Ω / 6 pF typical
Maximum input voltage	\pm 60 V
Maximum rated voltage to earth	\pm 60 V

(3) Current measurement specifications

Number of input channels	1 channel (only CH1 enabled)														
Input terminal profile	Probe1: Dedicated connector (ME15W)														
Input type	Current sensor input method														
Range	<table border="0"> <tr> <td>Probe1: 40 mA, 80 mA, 200 mA, 400 mA, 800 mA, 2 A</td> <td>(with 2 A sensor)</td> </tr> <tr> <td>400 mA, 800 mA, 2 A, 4 A, 8 A, 20 A</td> <td>(with 20 A sensor)</td> </tr> <tr> <td>1 A, 2 A, 5 A, 10 A, 20 A, 50 A</td> <td>(with 50 A sensor)</td> </tr> <tr> <td>4 A, 8 A, 20 A, 40 A, 80 A, 200 A</td> <td>(with 200 A sensor)</td> </tr> <tr> <td>10 A, 20 A, 50 A, 100 A, 200 A, 500 A</td> <td>(with 500 A sensor)</td> </tr> <tr> <td>20 A, 40 A, 100 A, 200 A, 400 A, 1 kA</td> <td>(with 1000 A sensor)</td> </tr> <tr> <td>40 A, 80 A, 200 A, 400 A, 800 A, 2 kA</td> <td>(with 2000 A sensor)</td> </tr> </table>	Probe1: 40 mA, 80 mA, 200 mA, 400 mA, 800 mA, 2 A	(with 2 A sensor)	400 mA, 800 mA, 2 A, 4 A, 8 A, 20 A	(with 20 A sensor)	1 A, 2 A, 5 A, 10 A, 20 A, 50 A	(with 50 A sensor)	4 A, 8 A, 20 A, 40 A, 80 A, 200 A	(with 200 A sensor)	10 A, 20 A, 50 A, 100 A, 200 A, 500 A	(with 500 A sensor)	20 A, 40 A, 100 A, 200 A, 400 A, 1 kA	(with 1000 A sensor)	40 A, 80 A, 200 A, 400 A, 800 A, 2 kA	(with 2000 A sensor)
Probe1: 40 mA, 80 mA, 200 mA, 400 mA, 800 mA, 2 A	(with 2 A sensor)														
400 mA, 800 mA, 2 A, 4 A, 8 A, 20 A	(with 20 A sensor)														
1 A, 2 A, 5 A, 10 A, 20 A, 50 A	(with 50 A sensor)														
4 A, 8 A, 20 A, 40 A, 80 A, 200 A	(with 200 A sensor)														
10 A, 20 A, 50 A, 100 A, 200 A, 500 A	(with 500 A sensor)														
20 A, 40 A, 100 A, 200 A, 400 A, 1 kA	(with 1000 A sensor)														
40 A, 80 A, 200 A, 400 A, 800 A, 2 kA	(with 2000 A sensor)														
Crest factor	3 relative to current range ratings														

(4) Impedance measurement specifications

Impedance measurement repeatability

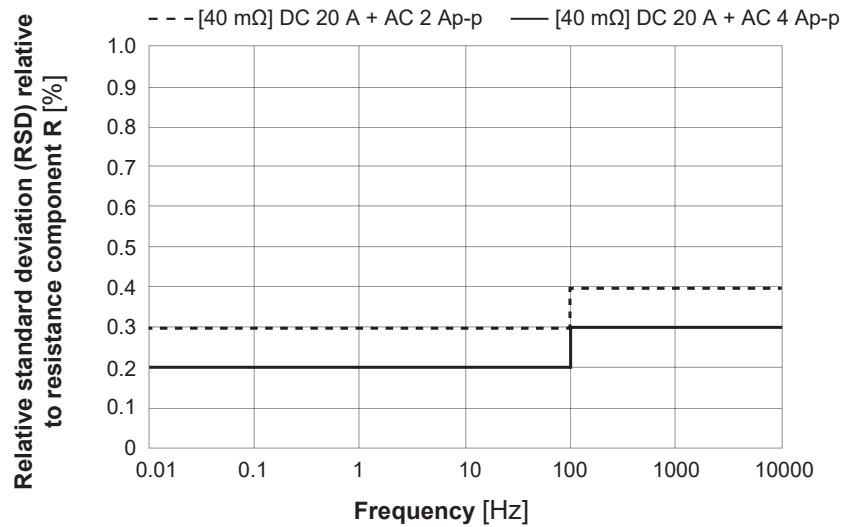

Relative standard deviation of measured resistance value when measuring resistive load (R = 40 mΩ, DC 20 A)

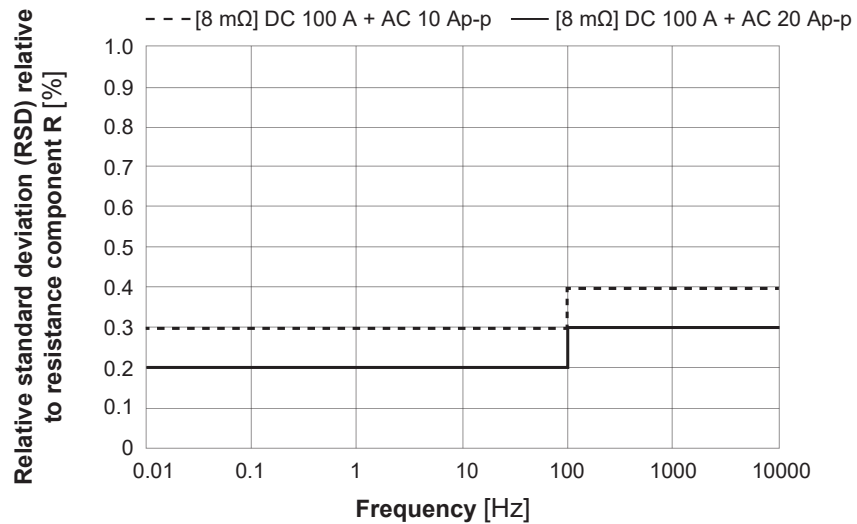

Relative standard deviation of measured resistance value when measuring resistive load (R = 8 mΩ, DC 100 A)

Measurement conditions

Software: EA5701 ALDAS-Mini

Voltage range: 6 V

Current sensor: CT6845A

Current range: 20 A range (for DC 20 A), 100 A range (for DC 100 A)

Other settings: FAST measurement speed, noise reduction enabled

No electrical noise

(5) Accuracy specifications

Accuracy guarantee conditions

Accuracy guarantee duration: 1 year

Accuracy guarantee temperature and humidity range: 23°C ±3°C, 80% RH or less

Warm-up time: 30 min. or more

Other: Sine-wave input, power factor of 1 or DC input, line-to-earth voltage of 0 V, within ±1°C after zero adjustment, within accuracy guarantee range

Accuracy guarantee range

1% to 100% of range

Voltage, current, power, and phase angle measurement accuracy

Accuracy	$\pm(\% \text{ of reading} + \% \text{ of range})$	
	Voltage (U)	Current (I)
DC	0.07 % + 0.03 %	0.07 % + 0.03 %
f = 100 Hz	0.02 % + 0.02 %	0.02 % + 0.02 %
100 Hz < f ≤ 440 Hz	0.04% + 0.02%	0.04% + 0.02%
440 Hz < f ≤ 1 kHz	0.05% + 0.04%	0.05% + 0.04%
1 kHz < f ≤ 10 kHz	0.13% + 0.05%	0.13% + 0.05%
10 kHz < f ≤ 50 kHz	0.25% + 0.05%	0.25% + 0.05%
50 kHz < f ≤ 100 kHz	$(0.01 \times f + 0.20)\% + 0.1\%$	$(0.01 \times f + 0.20)\% + 0.1\%$

Accuracy	$^{\circ}$
	Phase angle (ϕ) (Phase difference)
f = 100 Hz	$\pm 0.15^{\circ}$
100 Hz < f ≤ 440 Hz	$\pm 0.15^{\circ}$
440 Hz < f ≤ 1 kHz	$\pm 0.15^{\circ}$
1 kHz < f ≤ 10 kHz	$\pm 0.72^{\circ}$
10 kHz < f ≤ 50 kHz	$(0.020 \times f) \pm 0.7^{\circ}$
50 kHz < f ≤ 100 kHz	$(0.030 \times f) \pm 2.4^{\circ}$

- In the expressions listed above, the unit of f is kilohertz.
- Voltage and DC current accuracy figures are defined for DC voltage and current. Accuracy figures for frequencies other than DC are defined for RMS values.
- Phase difference accuracy values are defined for 100% input with a power factor of 0.
- For current and phase angle, add the current sensor's accuracy to the above accuracy figures.
- When using the 6 V range for voltage measurement, add $\pm 0.02\%$ of range to the voltage accuracy.
- When using a range that is 1/10, 1/25, or 1/50 of the current sensor's rating, add $\pm 0.02\%$ of range to the current accuracy.
- If the temperature varies by $\pm 1^{\circ}\text{C}$ or more after zero adjustment, add $\pm 0.01\%$ of range per $^{\circ}\text{C}$ to the DC voltage and current accuracy.

Effects of temperature	Add the following to the voltage and current accuracy within the range of 0°C to 20°C or 26°C to 40°C . For the DC of $\pm 0.01\%$ of reading per $^{\circ}\text{C}$, add another 0.01% of range per $^{\circ}\text{C}$.
-------------------------------	--

Effects of external magnetic fields	$\pm 1\%$ of range or less (400 A/m, in DC or 50 Hz/60 Hz magnetic field)
--	--

Functional specifications

(1) Current sensor phase correction

Functionality	Corrects current sensor high-frequency phase characteristics in calculations.
Operating modes	OFF/AUTO The AUTO setting can be selected when a current sensor that supports the automatic detection function is connected.
Correction value setting	Sets the frequency and phase difference for correction points. Frequency: 0.1 kHz to 5000.0 kHz (0.1 kHz increments) Phase difference: 0.000 deg to ± 180.000 deg (0.001 deg increments) When the operating mode is set to AUTO, these settings are configured automatically when a sensor is connected.

Interface specifications

(1) LAN

Number of ports	1 port
Connector	RJ-45
Rating/method	IEEE 802.3ab compliant
Transmission method	1000Base-T auto negotiation
Protocol	TCP/IP
Communication details	Settings and inquiries with communication commands from the PC application for the EA570x ALDAS
IP address (fixed)	IP address: 192.168.200.4 Subnet mask: 255.255.0.0 Default gateway: 0.0.0.0 (None) Communication command port No.: 23

9.3 EA5501 Source Module

General specifications

Operating environment	Indoor use, pollution degree 2, altitude up to 2000 m (6562 ft.)
Operating temperature and humidity range	0°C to 40°C (32°F to 104°F), 80% RH or less (no condensation)
Storage temperature and humidity range	-10°C to 50°C (14°F to 122°F), 80% RH or less (no condensation)
Standards	Safety: EN 61010 EMC: EN 61326 Class A
Power supply	Grid power Rated supply voltage: AC 100 V to 240 V (Assuming voltage fluctuation of $\pm 10\%$) Rated power-supply frequency: 50 Hz, 60 Hz Anticipated transient overvoltage: 2500 V Maximum rated power: 200 VA for main unit only At the maximum load applied to the power supply output port: 500 VA
Dimensions	Approx. 520W × 197H × 540D mm (20.5W × 7.8H × 21.3D in.) (excluding protruding parts)
Weight	Approx. 27 kg (59.5 lbs) (not including cables)
Product warranty duration	1 year
Accessories	See p.6 (EA5501 Source Module).
Option	See p.7 (Cable for signal superposition).

Input, output, measurement specifications

(1) Signal source specifications

Source operation method	Electronic load
Load operating modes	Constant-current (CC)

Signal superposition method

Signal superposition by drawing some of the DC current flowing to the measurement target to the Source Module (See figure below.)

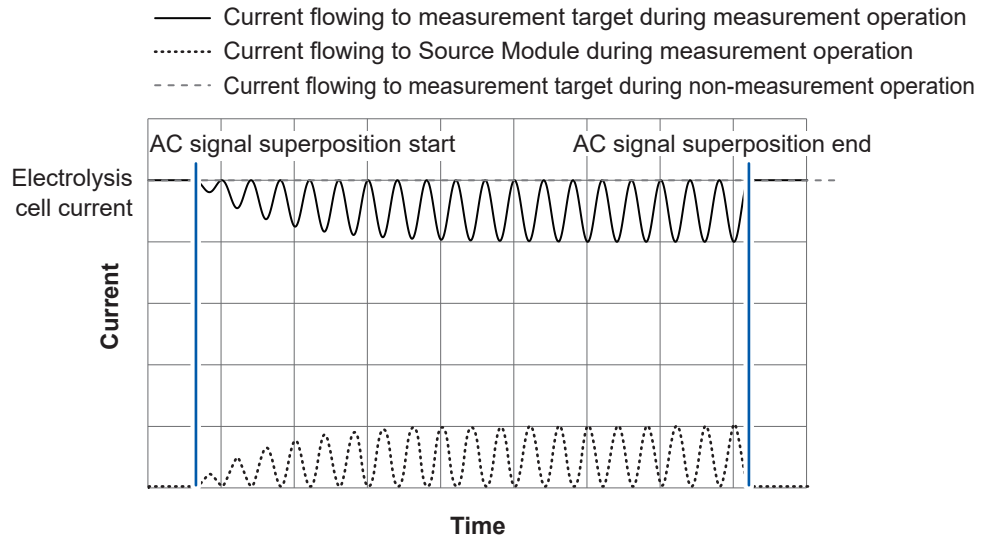
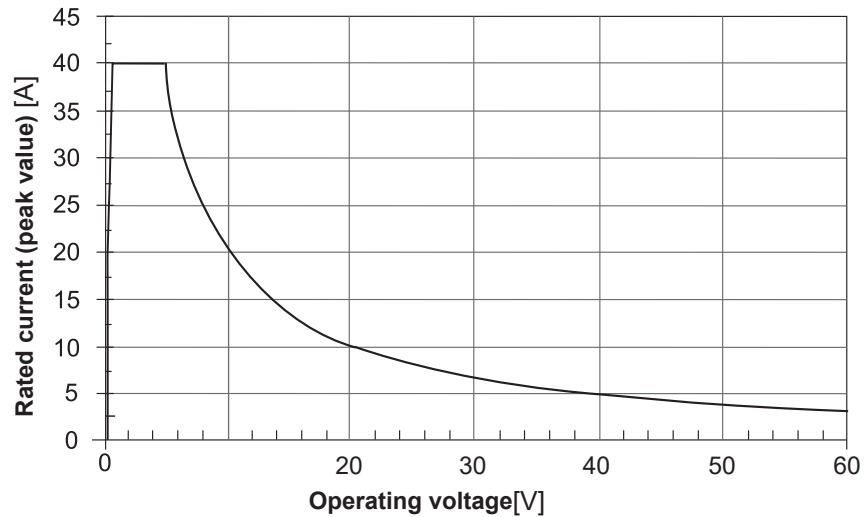

Diagram of current applied to measurement target during measurement

Signal superposition terminal ratings

- Rated power: 200 W
- Operating voltage: 0.25 V to 60 V
- Rated current: See figure below.



Rated current relative to Source Module operating voltage

System Specifications

(1) Power outlets

Power outlets	Number of power outlets	2
	Power supply	100 V to 240 V 50 Hz/60 Hz 300 VA (Outputs voltage input to the power inlet.)
	Connectable devices	EA5301-01, EA5301-02, EA5301-03, EA5301-04, EA5301-05, EA5301-06, EA5301-07, EA5301-08, CT9557

(2) LAN interface

Number of ports	2 ports (For PC connection and Sense Module/Source Module connection)
Connector	RJ-45 8-pole (shielded type)
Cable specifications	STP LAN cable
Rating/method	IEEE 802.3ab compliant
Transmission method	1000Base-T auto negotiation

9.4 L1100 Sense Cable

The L1100 is designed specifically for use with the following products:

EA5301-01, EA5301-02, EA5301-03, EA5301-04, EA5301-05, EA5301-06, EA5301-07, EA5301-08

General specifications

Operating environment	Indoor use, pollution degree 2, altitude up to 2000 m (6562 ft.)
Operating temperature and humidity range	0°C to 40°C (32°F to 104°F), 80% RH or less (non-condensing)
Storage temperature and humidity range	-10°C to 50°C (14°F to 122°F), 80% RH or less (non-condensing)
Dimensions	Full length: Approx. 2215 mm (87.2 in.)
Weight	Approx. 197 g (6.9 oz.)
Maximum input voltage	60 V DC
Maximum rated line-to-ground voltage	60 V DC
Maximum input current	50 mA
Product warranty duration	None (out of scope of coverage)

9.5 L1150 Source Cable

The L1150 is designed specifically for use with the following products:

EA5501

General specifications

Operating environment	Indoor use, pollution degree 2, altitude up to 2000 m (6562 ft.)
Operating temperature and humidity range	0°C to 40°C (32°F to 104°F), 80% RH or less (non-condensing)
Storage temperature and humidity range	-10°C to 50°C (14°F to 122°F), 80% RH or less (non-condensing)
Dimensions	Full length: Approx. 2200 mm (86.6 in.)
Weight	Approx. 1.1 kg (2.4 lb.)
Maximum input voltage	60 V DC
Maximum rated line-to-ground voltage	60 V DC
Maximum input current	40 A AC/DC, continuous
Clip opening dimensions	15 mm or more
Product warranty duration	None (out of scope of coverage)

10 Maintenance and Service

Shipping Precautions

CAUTION

Observe the following when shipping the products:



- Remove the optional equipment.
- When requesting repair, include a description of the malfunction.
- Use the original packaging materials in which the products were delivered, and then place it in an additional box.

Failure to follow this guidance could cause damage to the products during shipment.

10.1 Repairs, Inspections, and Cleaning

WARNING



- Do not attempt to modify, disassemble, or repair the Sense Module or Source Module yourself.

Failure to follow this guidance could cause bodily injury or fire.

Calibration

The calibration interval depends on factors such as the operating conditions and environment. Please determine the appropriate calibration interval based on your operating conditions and environment and have Hioki calibrate the instrument accordingly on a regular basis.

Backing up data

When repairing or calibrating the system, we may initialize it. It is recommended to back up (save/write) data such as the settings and measured data before requesting service.

IMPORTANT

If requesting repair or calibration service from Hioki, please send the following three components together:

- Sense Module
- Source Module
- ALDAS (PC application) USB dongle key

Replaceable parts and service life

Some parts used in the products may deteriorate in characteristics after years of use.

It is recommended to replace these parts regularly to ensure long-term functionality.

To order replacements, please contact your authorized Hioki distributor or reseller.

Part service life varies with the operating environment and frequency of use.

Recommended replacement intervals do not guarantee continuous operation throughout the specified period.

Parts	Service life	Remarks and conditions
EA5301 Sense Module		
Electrolytic capacitor	About 10 years	Requires replacement of the printed circuit boards on which such parts are mounted.
Liquid crystal back-light (half life period of brightness)	About 8 years	If operated 24 hours per day
Fan motor	About 10 years	If operated 24 hours per day
Backup battery	About 10 years	Requires replacement if the time and date are significantly deviated.
Optical insulation element	About 10 years	If operated 24 hours per day
Optical connection cable connector	About 10 years	If operated 24 hours per day
EA5501 Source Module		
Backup battery	About 3 years	

Cleaning

CAUTION

- **Periodically clean the vents.**

Clogged vents could hamper the internal cooling effect of the modules, causing damage to them.



- **To clean the products, wipe them using a soft cloth moistened with water or a neutral detergent.**

Using solvent-containing detergents, such as benzene, alcohol, acetone, ether, ketone, thinner, and gasoline, or wiping the products with excessive force could cause deformation or discoloration.

IMPORTANT

Dirt on the Sense Cable or Source Cable clips should be removed gently with a dry and clean soft cloth or with an industrial-use cotton swab. The presence of any foreign material, such as dirt, on the clips can hinder their ability to make proper contact, thus adversely affecting the measurement results.

Gently wipe the Sense Module's display with a soft and dry cloth.

10.2 Troubleshooting

If damage is suspected, refer to the “Before returning the products for repair” (p. 117) to address the issues. If further assistance is needed, contact your authorized Hioki distributor or reseller.

Before returning the products for repair

Check the following items.

Issue	Cause	Solution
The modules does not turn on.	The power cords are not connected or not properly connected.	Connect the power cords properly.
The PC application does not start.	The USB dongle key is not connected to the PC.	Connect the USB dongle key to the PC.
The PC cannot connect to the system instruments.	The LAN cable is not connected or not connected properly.	Connect the LAN cable between modules and PC properly.
	The PC's IP address setting is not configured properly.	Configure the PC's IP address properly.
	No current sensor is connected.	Verify that the current sensor is properly connected to CH1 of the Sense Module.
Communications between the PC and modules were interrupted.	The modules have hung.	Reconnect the modules to PC. Restart the system.
Voltage and current measurement values are abnormal. Measured values were unstable.	The Sense Cable, Source Cable, and current sensor are not connected properly.	Verify that the Sense Cable, Source Cable, and current sensor are connected properly. To achieve stable measurements, see “Methods for Stabilizing Measurement” (p. 124).
	The voltage range and current range are not configured properly.	Configure the voltage range and current range properly.
	The current sensor's phase correction setting is not configured properly.	Configure the current sensor's phase correction setting (for the selected current sensor model) properly.
	The measurement signal amplitude is too small.	Check the measurement value, and if the I _{sig} is extremely small, please increase [Signal Amplitude] value in the measurement condition setting.
The PC application was slow, making measurement impossible.	The data is too large because there are many measurement points plotted on the graph.	Data is saved as a CSV format file in the [DataFiles] folder inside the project folder. If you do not need to compare the data, perform measurement with separate project file that contains no measurement data.
Measurement was aborted.	The PC went to sleep during measurement.	Configure the PC so that it does not go into sleep-mode.

10.3 Error Messages

- When an error is displayed on the LCD screen, repair is necessary. Contact your authorized Hioki distributor or reseller.
- Starting the system while the lines to be measured are live may damage it or cause an error to be displayed. Always start the system on first and then activate power to the lines to be measured once you have verified that the computer screen displays no errors.

If a measurement system error occurs, a dialog box including an error message will be displayed by the PC application.

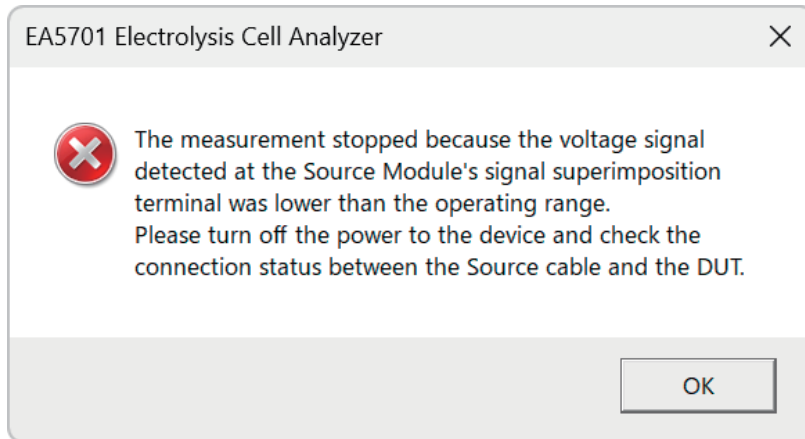

Please address the issue described in the error message.

Message	Solution
The measurement stopped because the measured current exceeded the measurable current range. Please go to the MEASURE tab and set the suitable current range.	Edit the measurement conditions and set the current range to an appropriate value. See "Configuring the Sense Module" (p.54).
The measurement stopped because the measured voltage exceeded the measurable voltage range. Please go to the MEASURE tab and set the suitable voltage range.	Edit the measurement conditions and set the voltage range to an appropriate value. See "Configuring the Sense Module" (p.54).
The measurement stopped because reverse voltage was detected at the Source Module's signal superposition terminal. Please turn off the power to the device and check the connection status between the Source Cable and the DUT.	Turn off power to the measurement target and Source Module and check whether the Source Cable is connected to the measurement target with the proper polarity *1. The Source cable's red clip should be connected to the positive (high-potential) side, and the black clip should be connected to the negative (low-potential) side. See "2.8 Connecting to the Measurement Target" (p.36).
The measurement stopped because the voltage signal detected at the Source Module's signal superposition terminal was lower than the operating range. Please turn off the power to the device and check the connection status between the Source Cable and the DUT.	Turn off power to the measurement target and Source Module and check whether the Source Cable is connected to the measurement target with the proper polarity *1. The Source Cable's red clip should be connected to the positive (high-potential) side, and the black clip should be connected to the negative (low-potential) side. See "2.8 Connecting to the Measurement Target" (p.36).

Message	Solution
The measurement stopped due to a communication failure with the device. To restore the connection, please go to the CONNECT tab and click the button under "Connection status".	<ul style="list-style-type: none"> • Check the LAN cable connection between the Sense Module and the Source Module. See "2.6 Connecting LAN Cables" (p.34). • Open the [CONNECT] tab on the main screen and reconnect the modules. See "7.4 Checking the System Connection Status and Reconnection" (p.96).
The measurement stopped because the watchdog protection was activated. To restore the connection, please go to the CONNECT tab and click the button under "Connection status".	
The measurement stopped because the current sensor in the Sense Module was changed. Please go to the MEASURE tab and check the setting for the Sense Module.	<ul style="list-style-type: none"> • Verify that the current sensor is connected to the Sense Module. • Open the [CONNECT] tab on the main screen and reconnect the modules. Once connected, do not disconnect or reconnect the current sensor. See "7.4 Checking the System Connection Status and Reconnection" (p.96). • Edit the measurement conditions and set the current range to an appropriate value. See "Configuring the Sense Module" (p.54).
The measurement stopped because an overvoltage was detected at the Source Module's signal superposition terminal. Please check if the DUT's voltage is within the rated value.	<ul style="list-style-type: none"> • Verify that the measurement target's DC voltage value does not exceed 60 V. See "Precautions for Use" (p.13), "9.3 EA5501 Source Module" (p.110). • Verify that the Source Cable is properly connected to the measurement target. See "2.8 Connecting to the Measurement Target" (p.36).
The measurement stopped because excessive power was detected at the Source Module's signal superposition terminal. Please check if the DUT's voltage is within the rated value.	
The measurement stopped because an overcurrent was detected at the Source Module's signal superposition terminal. Please check the condition of the Source Cable connection.	
The measurement stopped because an error occurred in the device. Please restart the device.	
The measurement stopped because the device has entered an abnormal state. Please restart the device.	<ol style="list-style-type: none"> 1. Turn off the Sense Module and Source Module and verify that the following two LAN cables are connected: <ul style="list-style-type: none"> • Between the Sense Module and the Source Module • Between the Source Module and the PC 2. Turn the Sense Module and Source Module back on.
The measurement stopped due to an external error in the device. Please restart the device.	
The measurement stopped because the Source Module shut down. Please restart the device.	
The measurement stopped because the Source Module overheated. Please check the Source Module installation and verify that the vent is not obstructed.	

10.4 Disposal of the Products

When disposing of the products, remove the lithium batteries and dispose of the batteries in accordance with local regulations. Dispose of all optional accessories in accordance with applicable instructions.

WARNING

- Do not short-circuit the batteries.
- Do not charge the batteries.
-  ■ Do not disassemble batteries.
- Do not throw the batteries into fire or expose them to heat.

Failure to follow this guidance could cause the batteries to explode, resulting in bodily injury.



- **Before removing the lithium batteries, first set the switches of the modules to the off position and then remove the power cords and the measurement cables from the measurement target.**
- **Store the removed batteries out of reach of young children.**

CALIFORNIA, USA ONLY
Perchlorate Material - special handling may apply.
See <https://dtsc.ca.gov/perchlorate/>.

Impedance measurement during DC operation

The system measures the impedance of the measurement target (electrolysis cell) during DC operation with a DC power supply by using the four-terminal method to measure the voltage and measuring current using a current sensor. The impedance measurement procedure and principles are described below.

Measurement procedure

- 1 AC current superposition:** The Source Module draws in the load current I_{load} to generate the AC signal current I_{sig} which is use for superposition on the measurement target.
- 2 Voltage measurement:** The voltage drop V_{sig} due to the impedance of the measurement target is measured by the Sense Module.
- 3 Current measurement:** The AC current I_{sig} flowing to the measurement target is measured by the current sensor.
- 4 Impedance calculation:** The impedance is calculated from the measured voltage V_{sig} and current I_{sig} and the phase different θ using the following formulas:

Real part: $R = V_{sig} / I_{sig} * \cos\theta$

Imaginary part: $X = V_{sig} / I_{sig} * \sin\theta$

Superposing the AC signal onto the measurement target

The system superposes a sine wave signal on the DC power supply line of the operating measurement target. The Source Module draws in part of the electrolysis cell current I_{dc} and adds the AC current signal, I_{sig} to the current flowing to the measurement target by changing the load current I_{load} flowing to the Source Module over time. In other words, the current flowing to the measurement target never exceeds the supplied DC current value, even during impedance measurement with signal superposition.

Fig. 1 illustrates the AC current signal, I_{sig} when added to the measurement target DC power supply value. Note that during signal superposition for impedance measurement, the average value of the current flowing through the measurement target will be less than the current during non-measurement (without signal superposition).

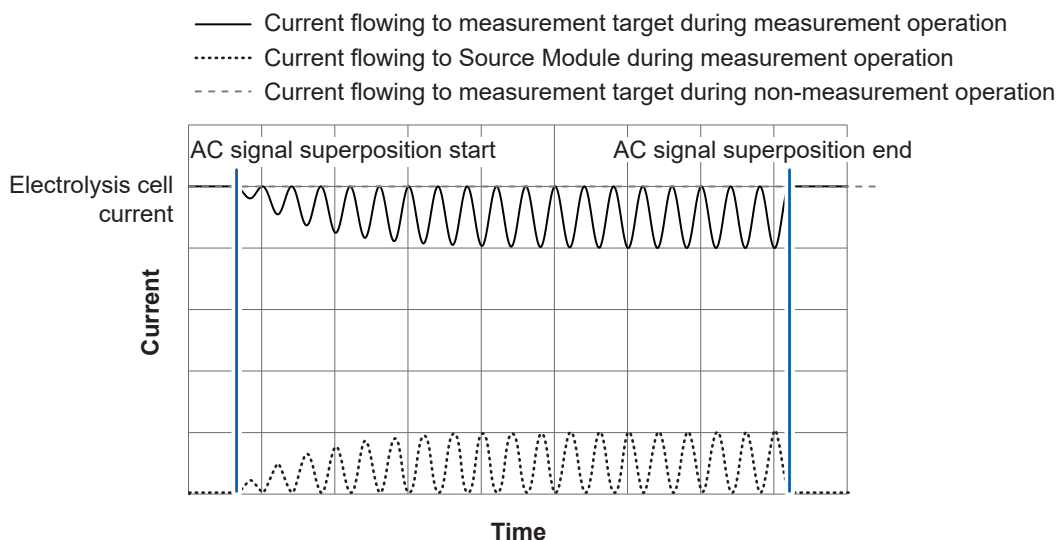

Fig. 1 Signal superposition by the Source Module

Voltage measurement using the four-terminal sensing

In general, electrolysis cells have low resistance, so this system uses a four-terminal method to reduce errors caused by the wiring resistance of the Sense Cable (see Fig. 2).

During impedance measurement, the AC component I_{sig} is added to the measurement target DC power line by the system's Source Module. At this time, the Sense Module detects the voltage drop V_{sig} caused by the impedance of the measurement target. Due to the high input impedance of the Sense Module's voltage detection circuit, there is no voltage drop across the Sense Cable's wiring resistor R_2 or contact resistor R_3 , since there are no current flows through them. In this way, the four-terminal method measurement eliminates the unwanted effects of the wiring resistance and contact resistance of the Sense Cable.

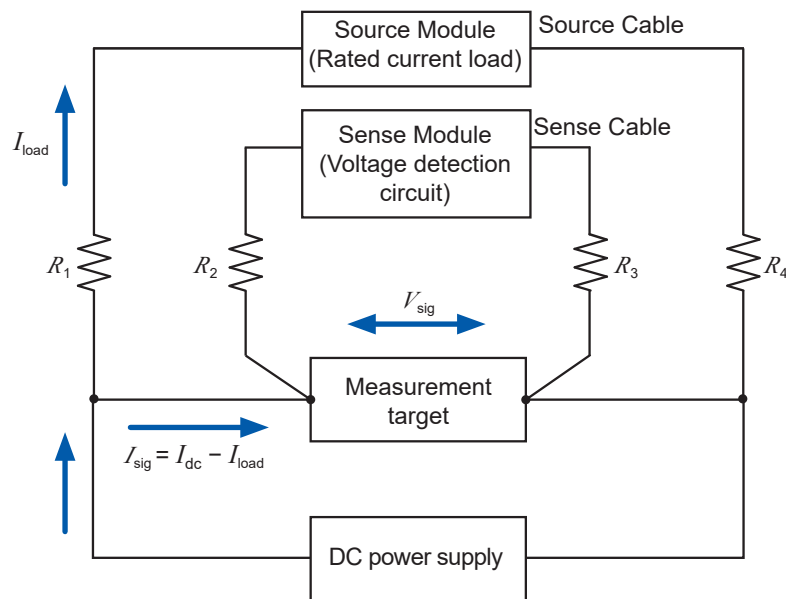

Fig. 2 Measurement using the four-terminal method

Measuring current flowing to the measurement target (electrolysis cell)

When performing impedance measurements on a system operating in a closed circuit with a DC power supply, such as an electrolysis cell, the measuring system sees the measurement target as connected in parallel with the DC power supply. Therefore, in a typical impedance measuring instrument, the measurement current signal I_{AC0} from the measurement signal source is divided into the current flowing to the measurement target, I_{AC1} , and the current flowing to the DC power supply, I_{AC2} . Since the impedance calculation relies on the instrument's applied measurement signal current I_{AC0} , the measured impedance result includes both the measurement target and the DC power supply, making it impossible to measure the impedance of the measurement target alone (Fig. 3). By contrast, the system measures current with a current sensor, allowing it to measure just the AC component I_{sig} flowing to the measurement target and thereby to measure the impedance of the measurement target alone as long as the current sensor is attached to an appropriate path (a path between the Source Cable contact and the measurement target) (Fig. 4).

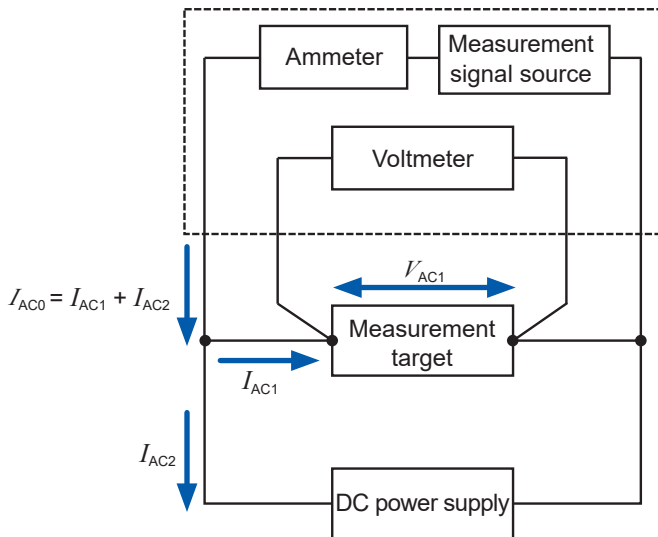

Fig. 3 When using a typical impedance tester

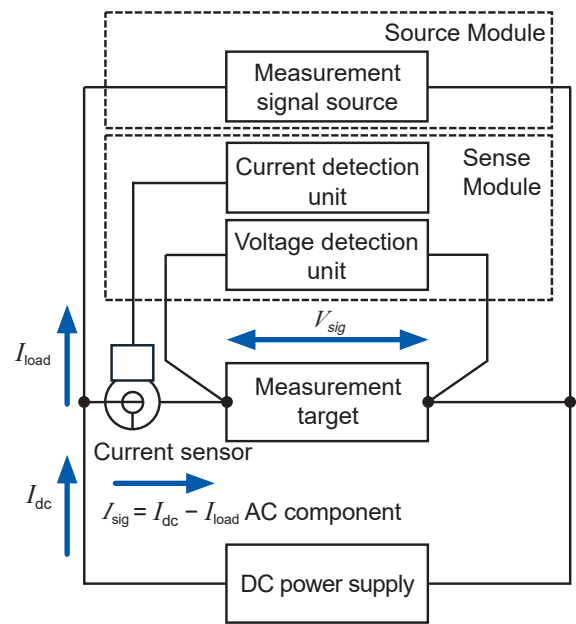
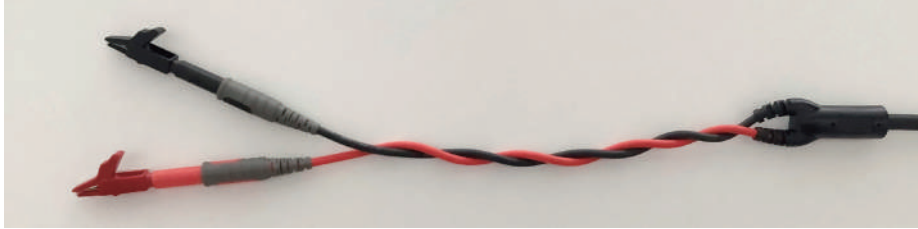

Fig. 4 When using this system

Methods for Stabilizing Measurement

Please twist the positive and negative wires of both the Sense and Source Cables as tightly as possible as shown in figure below.

For more details, see Fig. 5.



L1100 Sense Cable



L1150 Source Cable

Since the system measures extremely small impedance values using AC, it is susceptible to the effects of electromagnetic induction. The effects of electromagnetic induction occur when the Source-side loop (current superposition side) acts on the Sense-side loop (voltage detection side). The loop area and the distance between the Sense and Source-side loops determined the amount of induced magnetic flux from the Source-side that overlapped the Sense-side loop.

Therefore, in order to reduce the effects of electromagnetic induction, it is important to minimize the loop area and to place the Source and Sense Cables as far apart as possible. Specifically, twist the HIGH (positive) and LOW (negative) wires for both the Source and Sense Cable. The wire twist reduces the area of each loop and hence reduces the effects of electromagnetic induction during measurement.

Twisting the cables is also effective as a countermeasure against external inductive noise. Please twist both the Sense and Source Cables tightly and as close as possible to the measurement target.

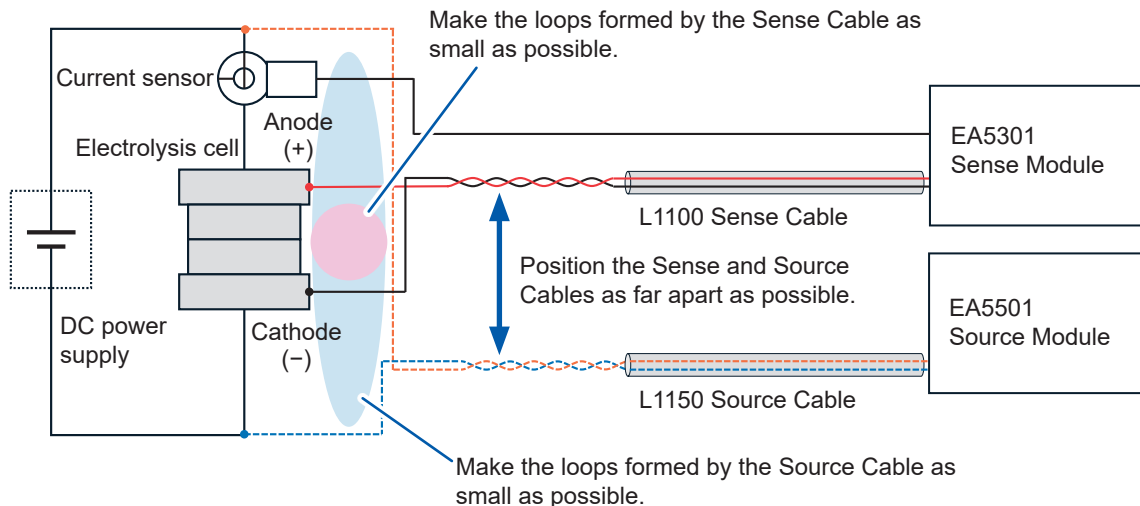

*Twist the cables together right up to the measurement target.

Fig. 5

Index

0ADJ key 18

A

AbsZ_SenseModule1_Ch 95
ALDAS format 89, 95
ArgZ_SenseModule1_Ch 95
Auto Scale 82

C

Cell area size 46, 76
Cell name 76
Cleaning 116
Cole-Cole plots 17
CONFIG 69, 74
CSV file 49
CurrentDensity 79
Current Input 31
Current range 54
Current sensor 31

D

Data 65
Data file 65, 81, 89
DataFiles 57
Data filter 70
Data format 94
Data table 56, 66, 81
Date 95
Date table
 |Z| [mΩ] 66
 Arg(Z) [deg] 66
 Date 66
 Elapsed Time [s] 66
 Frequency [Hz] 66
 Idc [A] 66
 Info 66
 Isig [Ap-p] 66
 No 66
 R [mΩ] 66
 Vdc [V] 66
 Vsig [Vp-p] 66
 X [mΩ] 66
Default gateway 25
Degaussing 40
Display legend 69
Disposal 120
DMAG 40

E

EIS Mode (Frequency Sweep) 47
ElapsedTime 95
Export I-V data 79

F

Fast 48, 50, 52
File path 79, 94
Formulas (Impedance calculation) 121

G

Graph type 69

H

Handles 21

I

Idc 74, 77, 79
Idc_SenseModule1_Ch 95
I-Impedance plot 75
Impedance graph 56
Impedance real part (Highest frequency) 75, 77, 79
Impedance real part (Lowest frequency) 75, 77, 79
Input channels 19
InstrumentSettings 57
Invert Y-axis 69
IP address 24
I-Power Plot 75
IR-free Plot 74
IR-free voltage 74
Isig_SenseModule1_Ch 95
I-V data 73, 77
I-V graph 46, 56, 73, 74
I-V Plot 74

L

LAN 34
Line 82
Line&Point 82
Logging interval 51, 52
Logging Mode (Fixed Frequency) 47

M

MAC address 21
Main application window 56
Main breaker 20
MEASURE 59, 61, 63, 85, 86, 87
Measured data filename 48, 50, 52
MeasuredFrequency_SenseModule1_Ch 95
Measurement conditions files 86
Measurement point list 49
Measurement project 42
MeasurementSettings 57, 87
Measurement speed 48, 50, 52
Medium 48, 50, 52

Menu bar	56
Multi-plot format	89

N

Noise reduction	48, 50, 52
Nyquist plots	17

O

Ohmic resistance	74
------------------------	----

P

Phase correction function	54
Plot Highlight	82
Plot mode	69, 74
Line	69, 74
Line & Point	69, 74
Point	69, 74
Point	82
Power	75
Power key	18
Power outlets	20
Power supply inlet	19, 20
Probe 1 terminals	19

R

Relay cable	37
Repairs	115
Reset Axes	82
Rhf	75, 77, 79
RJ-45 connector	19, 20
Rlf	75, 77, 79
Rohm	46, 74, 76
R_SenseModule1_Ch	95

S

Sense Cable	30
Sense Module	18
SetFrequency	95
Shipping	115
Side menu	56
Signal amplitude	48, 51
Signal frequency	51
Signal superposition terminal	20
Single cell	38
Slow	48, 50, 52
Snap Shot	82
Source Cable	33
Source Module	20
Stack	38
Subnet mask	25
Sweep	47

T

Tab list	56
Target information	65, 81
Total measurement time	51, 53

U

USB dongle key	41
----------------------	----

V

Vdc	74, 77, 79
Vdc_SenseModule1_Ch	95
Voltage Input	30
Voltage input terminals	19
Voltage range	54
Vsig_SenseModule1_Ch	95

X

X-axis axis scale	74
linear scale	74
logarithmic scale	74
X-axis item	74
Current	74
Current Density	74
X-axis units	69
X_SenseModule1_Ch	95

Y

Y-axis item	69
Y-axis units	69

Z

Zero adjustment	40
ZView format	89

Warranty Certificate

HIOKI

Model	Serial number	Warranty period One (1) year from date of purchase (___ / ___)
-------	---------------	---

Customer name: _____

Customer address: _____

Important

- Please retain this warranty certificate. Duplicates cannot be reissued.
- Complete the certificate with the model number, serial number, and date of purchase, along with your name and address. The personal information you provide on this form will only be used to provide repair service and information about Hioki products and services.

This document certifies that the product has been inspected and verified to conform to Hioki's standards.

Please contact the place of purchase in the event of a malfunction and provide this document, in which case Hioki will repair or replace the product subject to the warranty terms described below.

Warranty terms

1. The product is guaranteed to operate properly during the warranty period (one [1] year from the date of purchase).
If the date of purchase is unknown, the warranty period is defined as one (1) year from the date (month and year) of manufacture (as indicated by the first four digits of the serial number in YYYY format).
2. If the product came with an AC adapter, the adapter is warranted for one (1) year from the date of purchase.
3. The accuracy of measured values and other data generated by the product is guaranteed as described in the product specifications.
4. In the event that the product or AC adapter malfunctions during its respective warranty period due to a defect of workmanship or materials, Hioki will repair or replace the product or AC adapter free of charge.
5. The following malfunctions and issues are not covered by the warranty and as such are not subject to free repair or replacement:
 - 1. Malfunctions or damage of consumables, parts with a defined service life, etc.
 - 2. Malfunctions or damage of connectors, cables, etc.
 - 3. Malfunctions or damage caused by shipment, dropping, relocation, etc., after purchase of the product
 - 4. Malfunctions or damage caused by inappropriate handling that violates information found in the instruction manual or on precautionary labeling on the product itself
 - 5. Malfunctions or damage caused by a failure to perform maintenance or inspections as required by law or recommended in the instruction manual
 - 6. Malfunctions or damage caused by fire, storms or flooding, earthquakes, lightning, power anomalies (involving voltage, frequency, etc.), war or unrest, contamination with radiation, or other acts of God
 - 7. Damage that is limited to the product's appearance (cosmetic blemishes, deformation of enclosure shape, fading of color, etc.)
 - 8. Other malfunctions or damage for which Hioki is not responsible
 - 9. After disassembly, such as opening the product, has been performed by the customer without permission by Hioki
6. The warranty will be considered invalidated in the following circumstances, in which case Hioki will be unable to perform service such as repair or calibration:
 - 1. If the product has been repaired or modified by a company, entity, or individual other than Hioki
 - 2. If the product has been embedded in another piece of equipment for use in a special application (aerospace, nuclear power, medical use, vehicle control, etc.) without Hioki's having received prior notice
7. If you experience a loss caused by use of the product and Hioki determines that it is responsible for the underlying issue, Hioki will provide compensation in an amount not to exceed the purchase price, with the following exceptions:
 - 1. Secondary damage arising from damage to a measured device or component that was caused by use of the product
 - 2. Damage arising from measurement results provided by the product
 - 3. Damage to a device other than the product that was sustained when connecting the device to the product (including via network connections)
8. Hioki reserves the right to decline to perform repair, calibration, or other service for products for which a certain amount of time has passed since their manufacture, products whose parts have been discontinued, and products that cannot be repaired due to unforeseen circumstances.

HIOKI E. E. CORPORATION

25-10 EN-1

HIOKI
www.hioki.com/



**All regional
contact
information**

HIOKI E.E. CORPORATION
81 Koizumi, Ueda, Nagano 386-1192 Japan

2402 EN

Edited and published by HIOKI E.E. CORPORATION

Printed in Japan

- Contents subject to change without notice.
- This document contains copyrighted content.
- It is prohibited to copy, reproduce, or modify the content of this document without permission.
- Company names, product names, etc. mentioned in this document are trademarks or registered trademarks of their respective companies.

Europe only

- EU declaration of conformity can be downloaded from our website.
- Contact in Europe: HIOKI EUROPE GmbH
Helfmann-Park 2, 65760 Eschborn, Germany hioki@hioki.eu