

ALDAS-E

Check for the latest edition and other language versions.



**Read carefully before use.
Keep for future reference.**

Safety Information ▶ p.15

Measurement Process ▶ p.21

Part Names and Functions ▶ p.24

Maintenance and Service ▶ p.129

Troubleshooting ▶ p.132

EN



Contents

Introduction.....	7
Inspecting Package Contents.....	8
Options (Sold Separately).....	10
Symbols and Abbreviations.....	13
Safety Information.....	15
Precautions for Use.....	17
Measurement Process.....	21

1 Overview 23

1.1 Product Overview and Features.....	23
1.2 Part Names and Functions.....	24
Control Module.....	24
Sense Module.....	26
Source Module.....	28
1.3 System Architecture.....	30
1.4 Rack Cabinet Configuration.....	31

2 Preparing for Measurement 33

2.1 Inspecting the Products Before Use.....	33
2.2 Installing the PC Application.....	34
2.3 Setting the IP Address of Each Device.....	38
Setting the IP address of the PC.....	39
Setting the IP address of the Control Modules (for the second and subsequent modules).....	41
Setting the IP address of the Sense Modules (for the second and subsequent modules).....	41
2.4 Connecting the LAN Cables.....	42
2.5 Connecting the Source Cables.....	43
2.6 Connecting the Sense Cables (Voltage Input).....	45
2.7 Connecting the Current Sensor (Current Input).....	46
2.8 Supplying Power.....	48
Connecting the power cords.....	49
Turning on the system.....	49
Turning off the system.....	49
2.9 Zero Adjustment and Degaussing (DMAG).....	50
2.10 Connecting to the Measurement Target.....	51

3 Configuring the PC Application 55

3.1 Inserting a USB Dongle Key into the PC.....	55
3.2 Launching the EA5702 ALDAS-E PC Application.....	55
3.3 Creating a Measurement Project.....	56
3.4 Setting the System Configuration (Communication Connection with the System).....	58
3.5 Setting the Measurement Method.....	60
Setting the measurement target (DUT).....	60
Setting the measurement method.....	61
Setting the measurement conditions: EIS Mode (Frequency Sweep).....	62
Setting the measurement conditions: Logging Mode (Fixed Frequency).....	64
Setting the measurement conditions: Logging Mode (Only DC Measurements).....	66
Configuring the Sense Module.....	67
3.6 Confirming the Settings.....	68
3.7 Description of Main Application Window.....	69
3.8 Checking the Folders and Files of the Measurement Project.....	70

4 Making Measurements 71

4.1 Starting/Stopping the Measurement and Checking the Progress.....	71
4.2 Continuous Measurement (When There Are Multiple Measurement Conditions).....	72

5 Checking Impedance Measurement Results 73

5.1 Checking the Measurement Data.....	73
Data table explanation.....	74
Checking the measurement conditions linked to the data file.....	75
5.2 Configuring the Impedance Graph Settings.....	76
5.3 Setting the Data Filter.....	77

6 I-V Graph 79

- 6.1 Displaying the I-V Graph79
- 6.2 Configuring the I-V Graph Settings....80
- 6.3 Editing I-V Data.....81
 - Editing cell information81
 - Editing the I-V information82
- 6.4 Exporting the I-V Data84

7 Graph Common Operation 85

- 7.1 Setting for Displaying or Hiding the Measurement Data Graph.....85
- 7.2 Viewing Graphs86
- 7.3 Displaying the Data Details on Graphs87
- 7.4 Setting the Graph Color and Marker Shape88

8 Manipulating Files 89

- 8.1 Checking the System Connection Status and Reconnection89
- 8.2 Using the Measurement Conditions Files90
 - Adding, deleting, and sorting the measurement conditions90
 - Changing the existing measurement conditions91
 - Adding the existing measurement conditions92
 - Changing the measurement condition file names93
- 8.3 Using the Data Files.....94
 - Reading the data files94
 - Changing the data file names96
 - Deleting data files from the list.....97
 - Exporting data files99
- 8.4 Manipulating Project Files101

9 Ending Measurement 103

- 9.1 Exiting the PC Application103
- 9.2 Turning Off the System Power.....103
- 9.3 Disconnecting the Cables and Current Sensor from the Measurement Target103

10 Sensor Branch Module 105

- 10.1 Overview of the Sensor Branch Module105
- 10.2 Part Names and Functions105
- 10.3 Current Sensor Rating Setting (Switch).....106
- 10.4 Sensor Branch Module Connection Method106

11 Specifications 107

- 11.1 EA5702 ALDAS-E107
 - General specifications.....107
 - Functional specifications108
- 11.2 EA5302 Sense Module.....112
 - General specifications.....112
 - Input, output, measurement specifications113
 - Functional specifications116
 - Interface specifications.....116
- 11.3 EA5502 Source Module.....117
 - General specifications.....117
 - Input, output, measurement specifications117
 - Interface specifications.....118
 - EA5502 operation range119
- 11.4 EA5901 Control Module120
 - General specifications.....120
 - System specifications120
 - Input, output, measurement specifications121
 - Functional specifications122
- 11.5 Z5405 Sensor Branch Module.....123
 - General specifications.....123
 - Input and output specifications124
 - Functional specifications124
- 11.6 L1101, L1101-01 Sense Cable125
 - General specifications.....125
- 11.7 L1151, L1151-01 Source Cable126
 - General specifications.....126
- 11.8 Z5411 Rack Cabinet.....127
 - General specifications.....127
- 11.9 Z5412 Rack Cabinet127
 - General specifications.....127
- 11.10 Z5413 Rack Cabinet128
 - General specifications.....128

12 Maintenance and Service 129

- 12.1 Repairs, Inspections, and Cleaning .129
 - Calibration129
 - Replaceable parts and service life130
 - Cleaning131
- 12.2 Troubleshooting132
- 12.3 Error Messages134
 - EA5302 Sense Module134
 - PC application135
- 12.4 Disposal of the Products137

13 Embedding Devices into the Rack Cabinet 139

- 13.1 Preparations139
 - Removing the support legs and attaching the rack mount fittings139
- 13.2 Embedding Devices into the Rack Cabinet143
 - Rack cabinet configuration143
 - Embedding devices into the rack cabinet .145
- 13.3 Connecting the Power Cords and LAN Cables148
 - Connecting the power cords148
 - Connecting the LAN cables150

14 Moving and Installing the Rack Cabinet 153

- 14.1 Moving the Rack Cabinet153
- 14.2 Installing the Rack Cabinet154

15 Appendix 155

- Impedance measurement during DC operation155
- Methods for stabilizing measurement158

16 License Information 159

- EA5302 Sense Module159
- EA5901 Control Module159

Index 161

Warranty Certificate

11

12

13

14

15

6
16

7

8

9

10

Index

Introduction

Thank you for choosing the Hioki Active Line Device Analysis System (ALDAS).

To ensure your ability to get the most out of this system over the long term, please read this manual carefully and keep it available for future reference.

Information on download site

For details on the product application, the update file for the instrument, and the instruction manual, please check Hioki's website:

<https://cloud.gennect.net/dl>



Website for use within China.

<https://gennect.cn/dl>



Request for product user registration

We kindly request that you visit the following link to register your product to receive critical updates and information about the product:

<https://www.hioki.com/global/support/myhioki/registration>



The following documentation is available for reference according to your application:

Names of the instruction manuals	Contents	Form of supply
Instruction Manual	Product overview, operating instructions, function descriptions, and specifications for this system.	Hard copy
Operating Precautions	This document contains information for the safe use of this system. Please read Operating Precautions carefully, before using this system.	Hard copy

Target audience

This manual has been written for use by individuals who use the product or provide information about how to use the product.

In explaining how to use the product, it assumes electrical knowledge (equivalent of the knowledge possessed by a graduate of an electrical program at a technical high school).



Trademarks

- Microsoft Edge and Windows are trademarks of the Microsoft group of companies.
- Adobe and Adobe Acrobat Reader are either trademarks or registered trademarks of Adobe in the United States and other countries.
- Intel is a trademark of Intel Corporation or its subsidiaries in the United States and/or other countries.

Inspecting Package Contents

Upon receiving the products, inspect them for any damage or anomalies. If you discover any damage or find that the product does not perform as indicated in the specifications, please contact your authorized Hioki distributor or reseller.

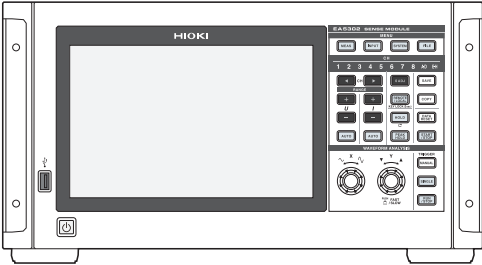
Confirm the package contents.

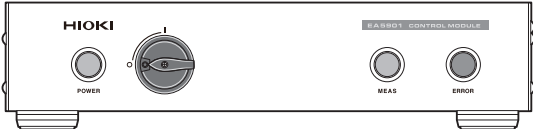
Product name	Accessories
<p>EA5302 Sense Module "EA5302 Sense Module model number" (p.9)</p> 	<ul style="list-style-type: none"> • Power cord (for main power supply) ×1 • Z7034 Power Cord (for Control Module connection) ×1 • Z7038 LAN Cable (1 m) ×1 • Z7044 Rack Mount Fittings ×1 (Bracket ×2, screw ×4, decorative screw ×4) • Download Guide ×1 • Operating Precautions (0990A903) ×1
<p>EA5502 Source Module</p> 	<ul style="list-style-type: none"> • Power cord (for main power supply) ×1 • Z7035 Power Cord (for Control Module connection) ×1 • Z7039 LAN Cable (1.5 m) ×1 • Z7042 Connection Cable (for EA5502 parallel operation) ×1 • Z7045 Rack Mount Fittings ×1 (Bracket ×2, screw ×4, decorative screw ×4) • PLZ4005WH2S Standard Accessory Set (excluding power cords) • Download Guide ×1 • Operating Precautions (0990A903) ×1
<p>EA5702 ALDAS-E (PC application)</p>  <p>The latest version of the manual is available for download from Hioki's website.</p>	<ul style="list-style-type: none"> • Z4006 USB Flash Drive ×1 (PC application installer, Instruction Manual^{*1}) • USB dongle key (license key) ×1 <p>*1. For the instruction manuals in other languages, check Hioki's website.</p>
<p>EA5901 Control Module</p> 	<ul style="list-style-type: none"> • Power cord (for main power supply) ×1 • Z7034 Power Cord (for CT9557) ×1 • Z7041 Connection Cable (for EA5502 control operation) ×1 • Z7040 LAN Cable 3 m (for PC connection) ×1 • Z7046 Rack Mount Fittings ×1 (Bracket ×2, screw ×4, decorative screw ×4) • Download Guide ×1 • Operating Precautions (0990A903) ×1

IMPORTANT

The Z5411, Z5412, and Z5413 rack cabinets are pre-wired with power cords, LAN cables, and Z7041 Connection Cables (BNC to D-sub 25).

Since the racks are already wired, please do not use the individual power cords or LAN cables supplied with each module. Instead, store them securely to prevent loss or mix-ups.

EA5302 Sense Module model number

The branch part of the model number indicates the number of input channels.

Model number (order code)	Number of channels
EA5302-01	1
EA5302-02	2
EA5302-04	4
EA5302-08	8

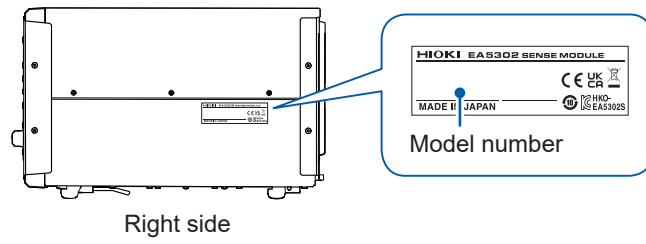

Options (Sold Separately)

The optional equipment listed below is available for the system. To purchase any optional equipment, please contact your authorized Hioki distributor or reseller.

Please note that optional equipment offerings are subject to change without advance notice. For the latest information, check Hioki's website.

Cable for signal superposition

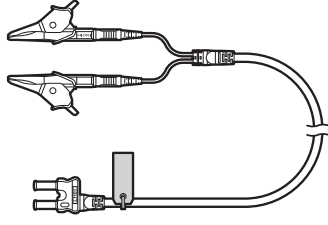

L1151, L1151-01	Source Cable Maximum input voltage: DC 1000 V / AC 1000 V Maximum input current: AC/DC 100 A continuous Full length: L1151 approximately 2.1 m, L1151-01 approximately 3 m Round crimp terminal: For M10 bolt size	
--------------------	------------------------------------------------------------------------------------------------------------------------------------------------------------------------------------------------------------------------------------------	-------------------------------------------------------------------------------------

Cable for voltage measurement

L1101, L1101-01	Sense Cable Maximum input voltage: DC 1000 V / AC 1000 V Full length: L1101 approximately 2.1 m, L1101-01 approximately 3 m Input/output terminal: Banana plug to banana plug, alligator clips included	
--------------------	----------------------------------------------------------------------------------------------------------------------------------------------------------------------------------------------------------------------------	--------------------------------------------------------------------------------------

Products for current measurement

For details, refer to the instruction manual that came with the current sensor.

Product name	Model number	Rated current rms	Frequency characteristics (Recommended impedance measurement frequency range)	Reference accuracy (Amplitude) \pm (% of reading + % of full scale)	Core diameter
AC/DC Current Probe (High accuracy clamp) 	CT6841A	20 A	DC to 2 MHz	$\pm 0.2\%$ $\pm 0.01\%$	$\varnothing 20$ mm
	CT6843A	200 A	DC to 700 kHz (Up to 10 kHz)		
	CT6844A	500 A	DC to 500 kHz (Up to 10 kHz)		
	CT6845A	500 A	DC to 200 kHz (Up to 10 kHz)		$\varnothing 50$ mm
	CT6846A	1000 A	DC to 100 kHz (Up to 10 kHz)		
AC/DC Current Sensor (High accuracy pass-through) 	CT6872	50 A	DC to 10 MHz	$\pm 0.03\%$ $\pm 0.007\%$	$\varnothing 24$ mm
	CT6873	200 A			
	CT6875A	500 A	DC to 2 MHz	$\pm 0.04\%$ $\pm 0.008\%$	$\varnothing 36$ mm
	CT6876A	1000 A	DC to 1.5 MHz		
	CT6877A	2000 A	DC to 1 MHz		

Product name	Model number	Rated current rms	Frequency characteristics (Recommended impedance measurement frequency range)	Reference accuracy (Amplitude) \pm (% of reading + % of full scale)	Core diameter
AC/DC Current Sensor (Ultra-high accuracy pass-through) 	CT6904A	500 A	DC to 4 MHz	$\pm 0.2\%$ $\pm 0.007\%$	$\varnothing 32$ mm

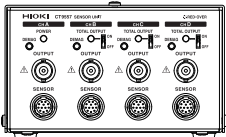
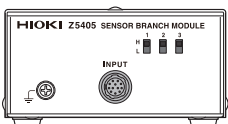
Product name	Model number	Remarks
Sensor Unit 	CT9557	The CT9557 adds current waveforms measured by multiple sensors and outputs a single signal. Use it when measuring multi-cable circuits. The CT9904 connection cable (optional) is required to connect to the EA5302 Sense Module.
Sensor Branch Module 	Z5405	The Z5405 is capable of branching the waveform output from the optional current measurement product to up to three lines. Use it when two or more EA5302 Sense Modules are installed. The CT9904 Connection Cable (optional) is required to connect with the EA5302 Sense Module.

Rack cabinet

Z5411	Rack cabinet (13U) Maximum configuration: EA5901 Control Module $\times 1$ EA5302 Sense Module $\times 1$ EA5502 Source Module $\times 1$	See "1.4 Rack Cabinet Configuration" (p.31)
Z5412	Rack cabinet (19U) Maximum configuration: EA5901 Control Module $\times 1$ EA5302 Sense Module $\times 2$ EA5502 Source Module $\times 2$	
Z5413	Rack cabinet (24U) Maximum configuration: EA5901 Control Module $\times 1$ EA5302 Sense Module $\times 3$ EA5502 Source Module $\times 2$	

Repair parts

For EA5302 Sense Module

Z7034	Power Cord (for control module connection)
Z7038	LAN cable 1 m
Z7044	Rack mount fittings (Bracket $\times 2$, screw $\times 4$, decorative screw $\times 4$)

Options (Sold Separately)

For EA5502 Source Module

Z7035	Power Cord (for control module connection)
Z7039	LAN cable 1.5 m
Z7042	Connection Cable (for EA5502 parallel operation)
Z7045	Rack mount fittings (Bracket ×2, screw ×4, decorative screw ×4)







For EA5901 Control Module

Z7034	Power Cord (for CT9557)
Z7040	LAN Cable 3.0 m (for PC connection)
Z7041	Connection Cable (for EA5502 control)
Z7046	Rack mount fittings (Bracket ×2, screw ×4, decorative screw ×4)









Symbols and Abbreviations

Safety



This manual classifies the seriousness of risks and hazard levels as described below.

 DANGER	Indicates an imminently hazardous situation that, if not avoided, will result in death or serious injury.
 WARNING	Indicates a potentially hazardous situation that, if not avoided, could result in death or serious injury.
 CAUTION	Indicates a potentially hazardous situation that, if not avoided, could result in minor or moderate injury or potential risks of damage to the supported product (or to other property).
IMPORTANT	Indicates information or content particularly important from the standpoint of operating or maintaining the product.
	Indicates a high-voltage hazard. Failure to verify safety or improper handling of the product will result in an electric shock, a burn, or injury, potentially leading to death.
	Indicates a prohibited action.
	Indicates the action which must be performed.

Symbols on the product

	Indicates the presence of a potential hazard. For more information about locations where this symbol appears on products' components, see "Precautions for Use" (p. 17) and warning messages listed at the beginning of operating instructions. In addition, see the accompanying document entitled "Operating Precautions" and "Current Sensor".
	Indicates the on position of the power switch.
	Indicates the off position of the power switch.
	Indicates the push-button switch that can turn on and off the product.
	Indicates the grounding terminal.
	Indicates the chassis terminal. The terminal is connected to the enclosure of the product.
	Indicates that the product can be used to measure direct current (DC) voltage/current or can be powered by a DC source.
	Indicates that the product can be used to measure alternating current (AC) voltage/current or can be powered by utility AC power.

Symbols for various standards

	Indicates that the product is subject to the Directive on Waste Electrical and Electronic Equipment (WEEE) in EU member nations. Dispose of the product by local regulations.
	Indicates that the product complies with standards imposed by EU directives.
	Indicates that the product complies with Korean regulations. EA5302 Sense Module Declarer: HIOKI KOREA CO., LTD. http://www.rra.go.kr/selfform/HKO-EA5302S
	EA5901 Control Module Declarer: HIOKI KOREA CO., LTD. http://www.rra.go.kr/selfform/HKO-EA5901
	EA5502 Source Module Model/device name: PLZ4005WH2/Electronic Load Declarer: KIKUSUI ELECTRONICS CORPORATION

Others

*	Indicates that additional information is described below.
(p.)	Indicates the page number to reference.
START (Bold)	The letters and key names on the screen are highlighted in bold.
[]	The names of user interface elements on the screen are enclosed in brackets ([]).
Windows	Unless otherwise noted, the term Windows is generically used to refer to Windows 10 and Windows 11.

Accuracy labeling

The accuracy of the measuring instrument is expressed by defining limit values for errors as a percentage of the reading, a percentage of the full scale, and a percentage of the setting, and in terms of digits.

Reading (display value)	Indicates the value displayed on the measuring instrument. Limit values for reading errors are expressed as a percentage of the reading (% of reading or % rdg).
Range	Indicates the measurement range of the measuring instrument. Limit values for range errors are expressed as a percentage of the range (% of range or % rng).
Setting (set value)	Indicates the set value, such as voltage and current, that the measuring instrument has been configured to output. Limit values for setting errors are expressed as a percentage of the setting (% of setting).
Digit (resolution)	Indicates the minimum display unit (in other words, the least significant digit that can have a value of one) for a digital measuring instrument. Limit values for digit errors are expressed in terms of digits.
Full scale (measurement range value)	Indicates each measurement range's value. This value does not indicate the maximum display value. The measuring instrument can display measured values that exceed the measurement range value. Limit values for full-scale errors are expressed as a percentage of the full scale (% of full scale or % f.s.).

Safety Information

The products included in this system has been designed in accordance with the international standard IEC 61010 and has undergone rigorous safety testing prior to shipment. However, using the system in a way not specified in this manual may compromise its safety features.

Carefully read the following safety notes before use.

DANGER



- **Familiarize yourself with the contents of this manual before use.**

Failure to follow this guidance will result in misuse, leading to serious bodily injury or damage to the products.

WARNING



- **If you have not previously used electrical measuring instruments, ensure adequate supervision by a technician with experience in electrical measurement.**

Failure to follow this guidance could result in electric shock. It could also cause serious incidents, such as heat generation, fire, or arc flash due to a short-circuit.

Measurement category

IEC 61010 defines measurement categories to ensure the safe use of measuring instruments. Test and measurement circuits are classified into three categories based on the type of mains they are intended to be connected to. A measuring instrument that does not have a measurement category cannot be used to measure a main power supply circuit.

⚠ DANGER

- Do not use a measuring instrument to measure a main power supply circuit whose category exceeds the instrument's rated measurement category.



- Do not use a measuring instrument that does not have a rated measurement category to measure a main power supply circuit.

Failure to follow this guidance will cause serious bodily injury or damage to the instrument and installation.

No measurement category (O)	Applicable to the measurement of other circuits that are not directly connected to the main power supply. Example: Measurement on the secondary-side equipment from the socket outlet of fixed equipment through a transformer, etc.
Measurement category II (CAT II)	Applicable to test and measuring circuits connected directly to utilization points (socket outlets and similar points) of a low-voltage mains installation. Example: Measurements on household appliances, portable tools, and similar equipment, and on the consumer side only of socket outlets in the fixed equipment.
Measurement category III (CAT III)	Applicable to test and measuring circuits connected to the distribution part of the a building's low-voltage mains installation. Example: Measurements on distribution boards (including secondary meters), photovoltaic panels, circuit breakers, wiring, including cables, bus-bars, junction boxes, switches, and socket outlets in a fixed equipment, as well as equipment for industrial use and some other equipment such as stationary motors with permanent connection to the fixed equipment.
Measurement category IV (CAT IV)	Applicable to test and measuring circuits connected at the source of the a building's low-voltage mains installation. Example: Measurements on devices installed before the main fuse or circuit breaker in the building installation.

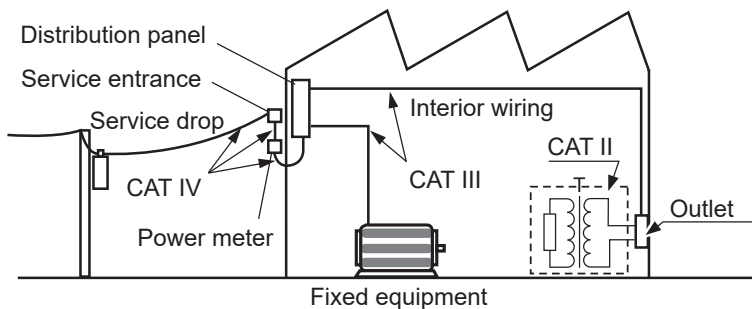

Precautions for Use

Be sure to follow the precautions listed below in order to use the system safely and in a manner that allows it to function effectively.

Use of the system should conform not only to its specifications, but also to the specifications of all accessories, options, and other equipment in use.

Installing the system

WARNING

■ **Do not use the system in locations such as the following:**



- Locations with direct sunlight exposure or high temperatures
- Locations where corrosive or explosive gases are generated
- Locations with powerful electromagnetic radiation exposure or electrostatic charges
- Close to inductive heating devices (high-frequency inductive heating devices, IH cooktops, etc.)
- Where it would be subject to a large amount of mechanical vibration
- Locations exposed to water, oil, chemicals, or solvents
- Where it would be exposed to high humidity or condensation
- Locations with an excessive amount of dust
- Locations with an unstable or inclined position

Doing so could damage the system or cause it to malfunction, resulting in bodily injury.

■ **Secure a space as specified in the vicinity of the vents (inlet/exhaust) of the EA5502 Source Module.**



Heat is expelled from the vents at the rear. Keep a distance between the Source Module and other units installed so that those units will not be directly exposed to the air expelled from the Source Module.

Leave at least 1000 mm from the vents to the wall, as accumulated heat could result in a fire. Do not put any objects in the area 1000 mm from the back of the module. See “Source Module” (p. 18).

■ **Place the Source Module, leaving enough space around it to facilitate unplugging the power cord.**

If there is not enough space left around, the power cannot be shut off immediately in an emergency. Failure to follow this guidance could result in bodily injury, fire, or damage to the system.

CAUTION



■ **Embed each device of the ALDAS-E into the relevant rack cabinet provided by Hioki.**

If the devices are stacked on top of each other, they could tip over or fall, causing damage.

- Place with its bottom side facing downward.
- Do not block vent openings.
- Maintain the clearance distances shown in the diagram below to prevent heat buildup.

Sense Module

All surfaces except bottom: 30 mm or more

Bottom: 15 mm or more above the installation surface (height of support legs).

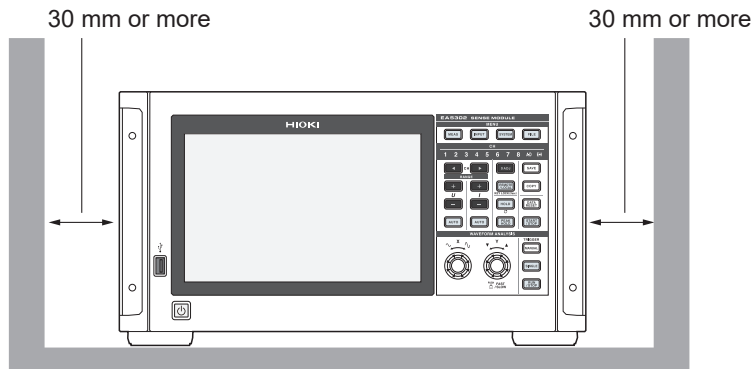

Source Module

Front: 300 mm or more

Rear: 1000 mm or more for a single module and 1500 mm or more for two modules

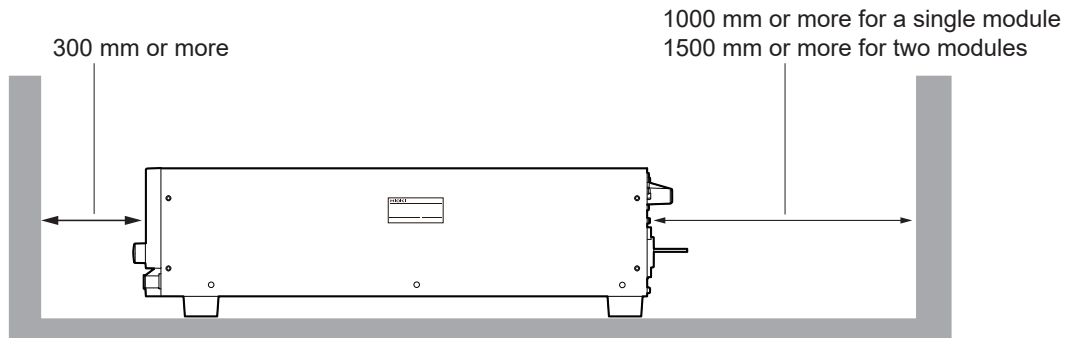

The modules are classified as a Class A device under the EN 61326 standard.

Use of them in a residential setting such as a neighborhood could interfere with reception of radio and television broadcasts.

If this occurs, take appropriate steps to counteract the issue.

Cautions for measurement

DANGER



- **Do not use the system for measurements on any circuits that exceed the ratings or specifications of the system.**

Failure to follow this guidance could cause damage to the system or overheating, resulting in serious bodily injury.

WARNING



- **Do not use the system for measuring AC voltages such as commercial power.**

Doing so could damage the products, resulting in bodily injury.

- **Do not touch the wires being measured.**

The wires being measured could become hot, possibly resulting in burns.

- **Do not input voltage or electric current into the input terminal while the system power is turned off.**

Failure to follow this guidance could damage the products.

Cautions for transporting the products

CAUTION



- **Do not subject the products to vibration or mechanical shock while transporting or handling them.**

- **Do not drop the products.**

Failure to follow this guidance could damage the products.

- **Work with at least one other person to hold the Source Module on the left and right sides.**

Source Module weight: Approx. 20.0 kg



- **Follow your company's safety guidelines, such as using anti-slip gloves and safety boots.**

Failure to follow this guidance could cause bodily injury.

Shipping precautions

CAUTION

Observe the following when shipping the products:



- Remove each device from the rack cabinet.
- Remove the accessories and optional equipment from the system.
- When requesting repair, include a description of the malfunction.
- Use the original packaging materials in which the instrument was delivered, and then place it in an additional box.

Failure to follow this guidance could cause damage to the products during shipment.

- When shipping the system, use the original boxes and packaging materials in which they were delivered. However, do not use the original box and packaging materials if they are damaged. If the original box and packaging materials cannot be used, contact your authorized Hioki distributor or reseller. You will be sent suitable boxes and packaging materials.
- When packing the system, disconnect test leads and a USB flash drive.
- When transporting the system, exercise care to avoid dropping them or otherwise subjecting them to rough handling.

Warranty

- Please note that in the event the system is embedded in another system or sold to another owner, Hioki is not liable for any direct or indirect damage sustained by the end-user.
- The L1101, L1101-01 Sense Cable, L1151, L1151-01 Source Cable, Z5411, Z5412, and Z5413 Rack Cabinets are not covered by the warranty.

Measurement Process

The basic measurement procedure is as follows:

1 Conduct a pre-measurement inspection

"2.1 Inspecting the Products Before Use" (p.33)

2 Prepare for measurement

"2.2 Installing the PC Application" (p.34)

"2.3 Setting the IP Address of Each Device" (p.38)

"2.4 Connecting the LAN Cables" (p.42)

"2.5 Connecting the Source Cables" (p.43)

"2.6 Connecting the Sense Cables (Voltage Input)" (p.45)

"2.7 Connecting the Current Sensor (Current Input)" (p.46)

"2.8 Supplying Power" (p.48)

For allow high-precision measurement, it is recommended to warm up allow the modules for at least 30 min. after turning them on and before starting measurements.

"2.9 Zero Adjustment and Degaussing (DMAG)" (p.50)

3 Connect the measurement target (DUT)

"2.10 Connecting to the Measurement Target" (p.51)

4 Configure the PC application

"3 Configuring the PC Application" (p.55)

5 Perform measurement

"4.1 Starting/Stopping the Measurement and Checking the Progress" (p.71)

6 Check the measurement results

"5 Checking Impedance Measurement Results" (p.73)

"6 I-V Graph" (p.79)

"7 Graph Common Operation" (p.85)

"8 Manipulating Files" (p.89)

7 Ending measurement (p.103)

1.1 Product Overview and Features

This product (ALDAS-E) is an Active Line Device Analysis System (ALDAS) that can conduct electrochemical impedance spectroscopy (EIS) measurements and plot I-V graph characteristics simultaneously for an electrolysis cell (EC) or fuel cell (FC) during its operation.

● Impedance measurement with excellent reproducibility

Impedance measurements can be performed with excellent reproducibility even in high electrical noise environments, such as those produced by DC power supplies during electrolysis operations.

● Simultaneous multichannel measurement

The system can measure the impedance of up to 48 channels (EA5302-08 × 6 modules) simultaneously.

● Cole-Cole plots (Nyquist plots)

The system can perform impedance measurement and generate Cole-Cole plots (Nyquist plots) based on user-defined frequency lists ranging from 0.01 Hz to 100 kHz.

● Extended duration impedance measurement

The system can measure impedance at a user-defined frequency and fixed interval, logging readings up to 180 days.

● Parameter comparisons on the graph

The measured data can be compared on a graph instantly to verify the measurement parameters of the experiment.

● I-V graph

The system plots the I-V graphs based on the DC current and DC voltage values acquired simultaneously with impedance measurements.

1.2 Part Names and Functions

Control Module

Front side

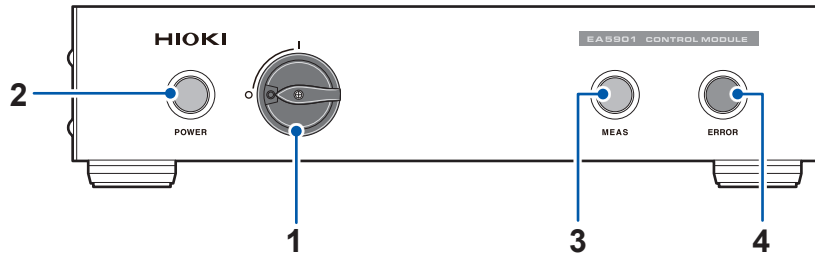

Rear side

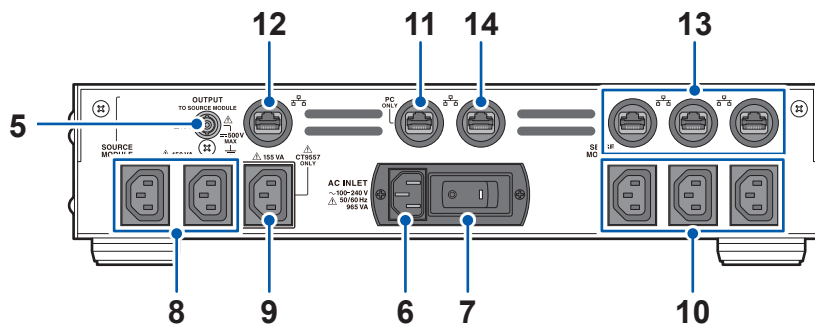

1	Start/stop switch	While the main breaker of the system is on, operating this switch turns on/off the main power of the entire system.	p.48
2	POWER LED	This LED blinks while the system is warming up after the power has been turned on. It lights up when the warm-up of the system is completed.	—
3	MEAS LED	This LED is lit during measurement.	
4	ERROR LED	This LED is lit while an error is activated.	
5	Control signal output terminal for Source Module	Connect the supplied Source Module control cable to this terminal. It allows you to control the Source Module from the system.	p.146
6	Power supply inlet	Connect the included power cord to the power supply.	p.48
7	Main breaker	Turns the entire system's main power supply on and off.	
8	Power outlet	Plug in the Source Module power cord to one of the power outlets.	p.148
9	Power outlet	If necessary, you can connect the optional CT9557 to the second power outlet.	
10	Power outlet	Plug in the Sense Module power cord to one of the power outlets.	p.150
11	RJ-45 connector	Connect the system and PC with a LAN cable.	
12	RJ-45 connector	Connect the system and primary Source Module with a LAN cable.	
13	RJ-45 connector	Connect the system and Sense Module with a LAN cable.	
14	RJ-45 connector	Use this connector when two systems are used. Connect these two systems with a LAN cable.	

Right side

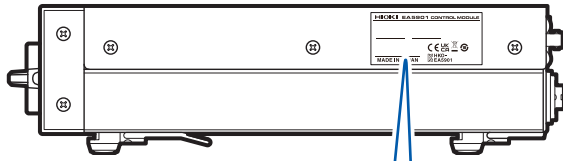

Label

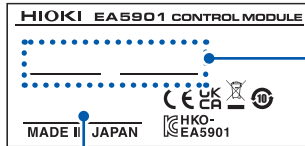

Serial number*1

MAC address

*1. Serial number

For the latest information, check Hioki's website.
Do not remove this label because the number is required for product tracking.

Sense Module

Front side

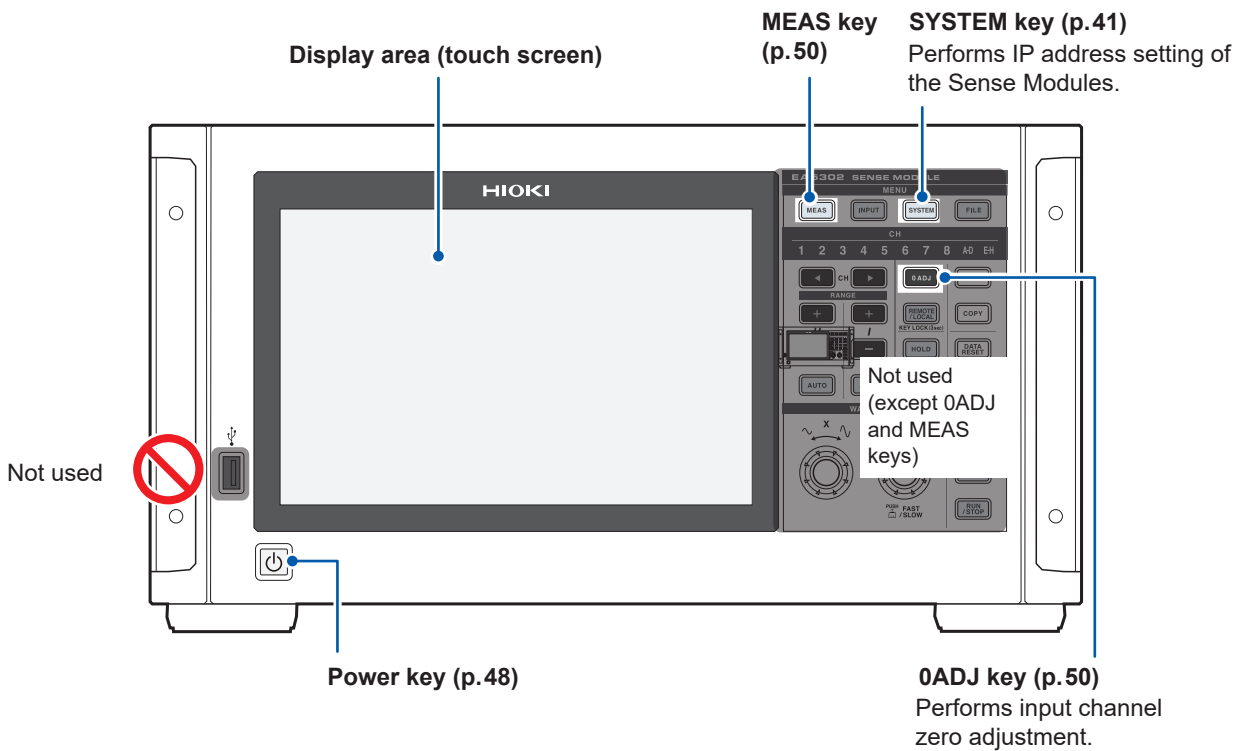

Handling the touch screen

CAUTION



- Do not press too hard on the touch screen.
- Do not use hard or sharp objects to operate the touch screen.

Failure to follow this guidance could damage the products.

Rear side

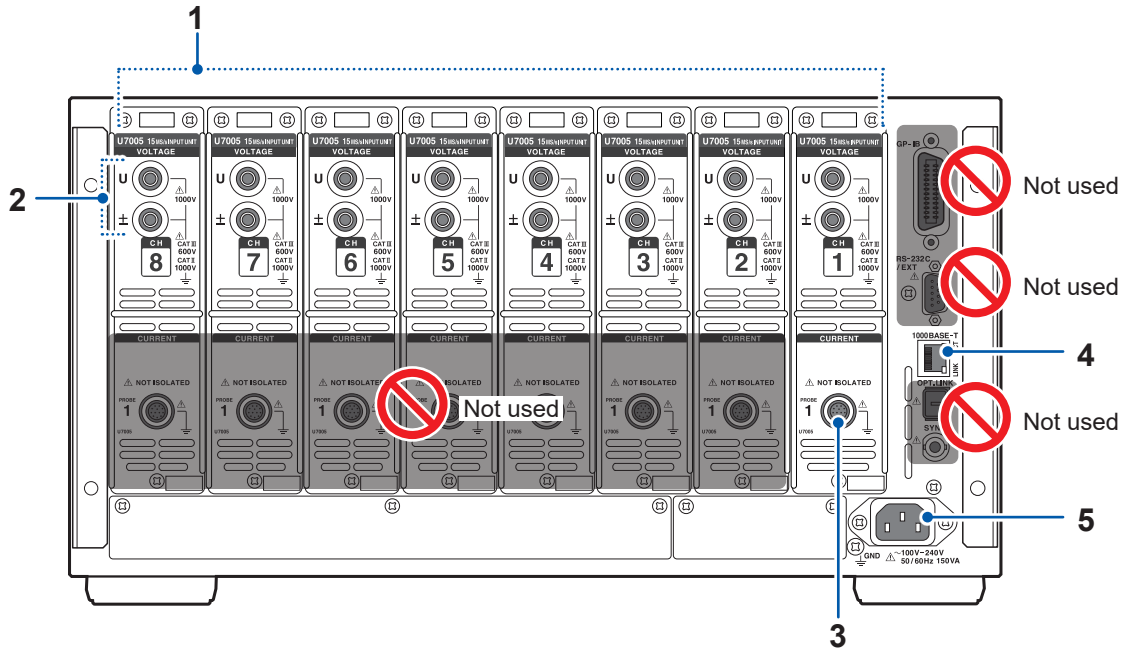

1	Input channels	The Sense Module accepts up to eight voltage input channels. (Specify the number of input channels when ordering.)	p.9
2	Voltage input terminals	Connect the L1101 Sense Cable.	p.45
3	Probe1 terminal (For current sensors)	Connect Hioki's current sensors. The Sense Module automatically recognizes current sensors. It also supplies power to the current sensors.	p.46
4	RJ-45 connector (Gigabit Ethernet)	Connect a LAN cable. Connect the Sense Module and Control Module with the LAN cable.	p.150
5	Power supply inlet	Connect the supplied power cord for connecting devices and plug it to the Control Module's power outlet.	p.149

Right side



Left side

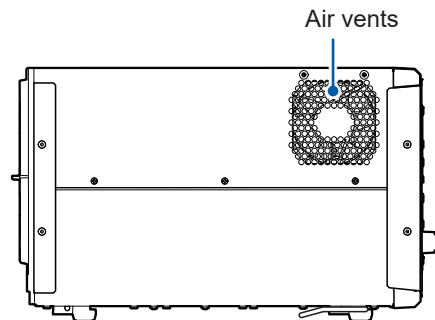

Label



Model number MAC address
Serial number*¹

*1. Serial number

For the latest information, check Hioki's website. Do not remove this label. It contains important information required for future service and support.

Source Module

Front side

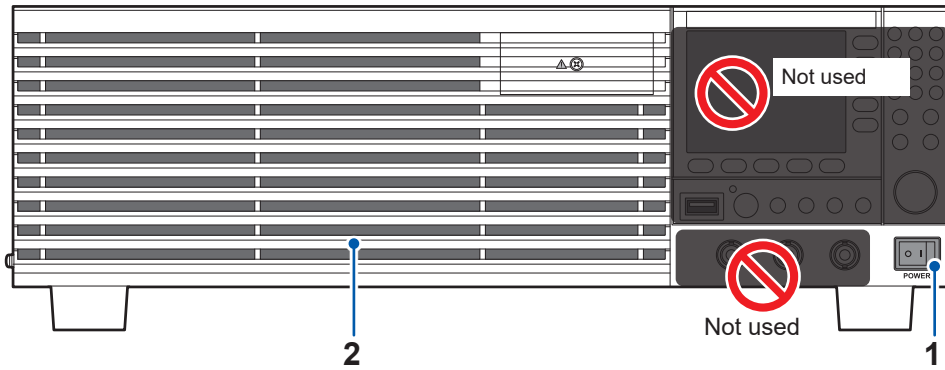

Rear side

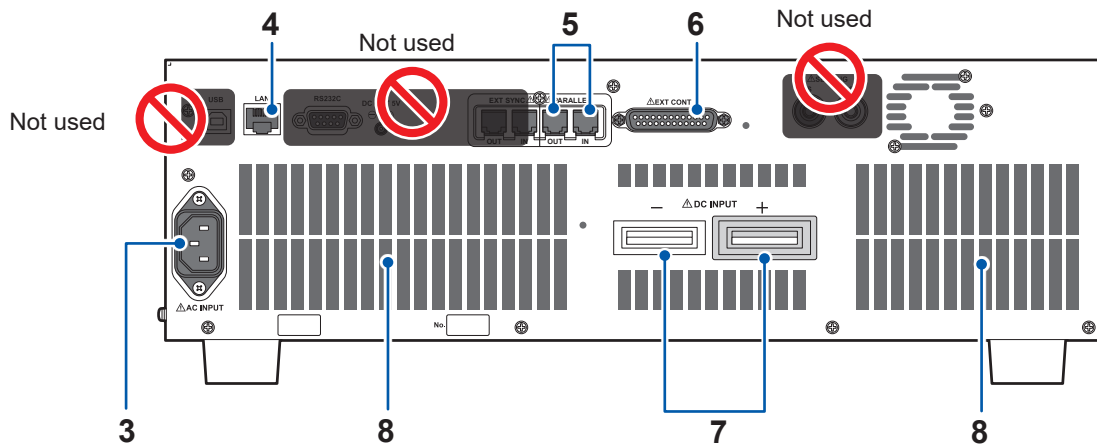

1	Power switch	Turns the system power on or off.	—
2	Air vents (inlet)	These ventilation holes prevent the internal parts from overheating. Do not block the air vents or insert any foreign object.	p. 17
3	Power supply inlet	Connect the supplied power cord and plug it in to the Control Module's power outlet.	p. 148
4	RJ-45 connector	Connect the Control Module and system with a LAN cable.	p. 150
5	PARALLEL connector	Use this connector when two systems are operated in parallel. A cover is attached to the terminal section.	p. 146
6	EXT CONT connector	Connect the Source Module control signal output terminal of the Control Module to this connector using the Source Module control cable. A cover is attached to the terminal section.	p. 146
7	Load input terminal (DC INPUT terminal)	Connect the L1151 Source Cable.	p. 43
8	Air vents (exhaust)	These ventilation holes prevent the internal parts from overheating. Do not block the air vents or insert any foreign object.	p. 17

Right side

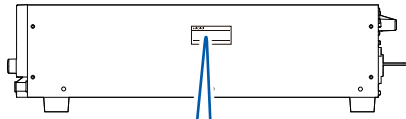

Label

*1. Serial number
For the latest information, check Hioki's website.
Do not remove this label because the number is required for product tracking.

Serial number^{*1} MAC address

1.3 System Architecture

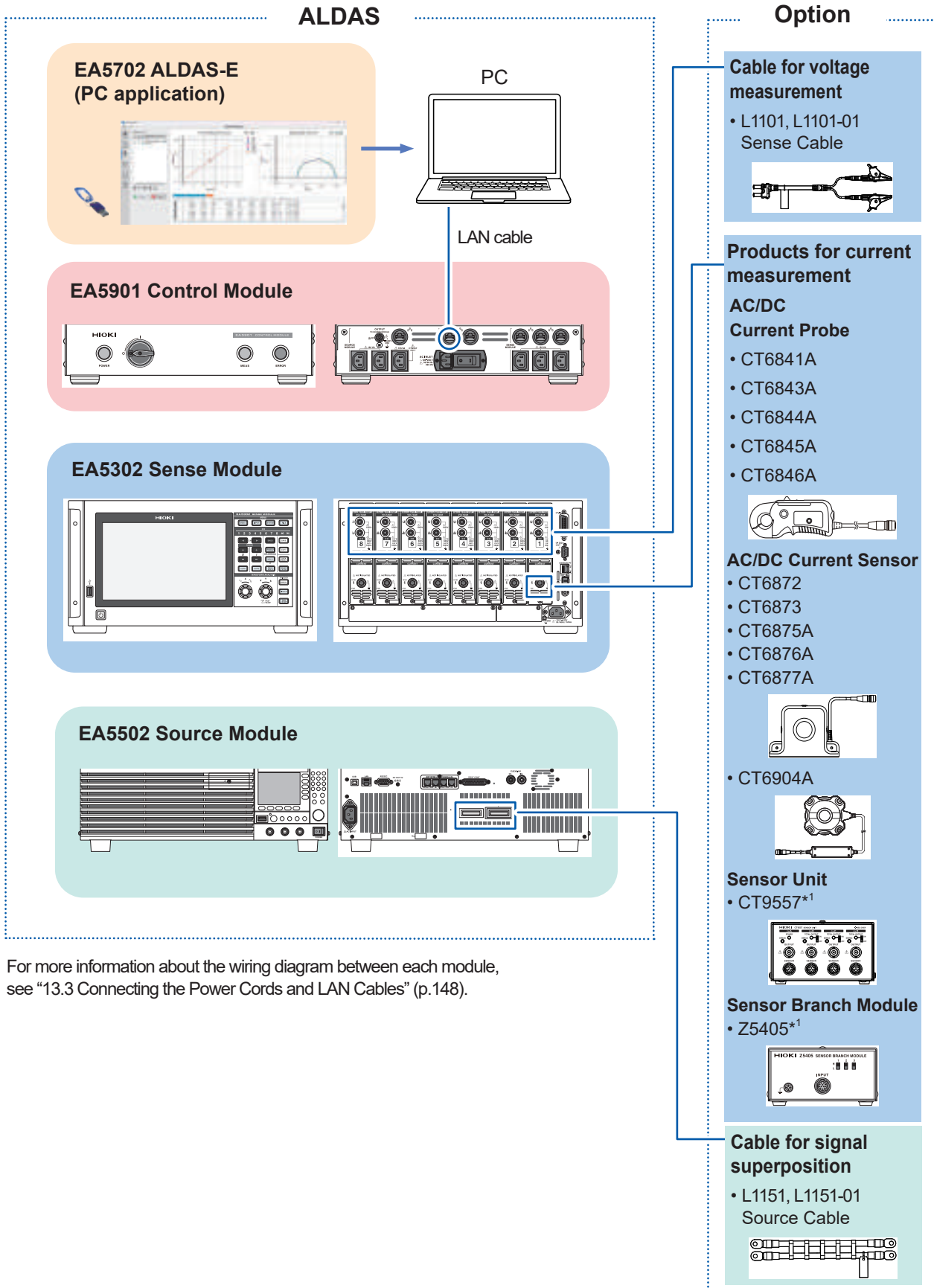

For more information about the wiring diagram between each module, see “13.3 Connecting the Power Cords and LAN Cables” (p.148).

*1. The CT9904 connection cable (optional) is required to connect to the EA5302 Sense Module.

1.4 Rack Cabinet Configuration



1

Overview

Specifications of the rack cabinet maximum configuration

Model	Z5411	Z5412	Z5413
Height	Approx. 860 mm (33.9 in.)	Approx. 1100 mm (43.3 in.)	Approx. 1360 mm (53.5 in.)
Weight	Approx. 85 kg	Approx. 125 kg	Approx. 150 kg
Maximum rated power	360 VA	815 VA	965 VA
EA5901 Control Module	1 module	1 module	1 module
EA5302 Sense Module	1 module	Up to 2 modules	Up to 3 modules
EA5502 Source Module	1 module	Up to 2 modules	Up to 2 modules

2

Preparing for Measurement

2.1 Inspecting the Products Before Use

Inspect the system for malfunctions or damage and check it for proper operation before use. If there is any malfunction or damage, please contact your authorized Hioki distributor or reseller.

Inspecting accessories and optional equipment

Make sure that . . .	Action
Insulation of the power cords, Sense Cable, and Source Cable are not damaged. No metal is exposed.	Do not use damaged products with the system to avoid electric shock or short circuits. The system cannot perform measurements in this state. Contact your authorized Hioki distributor or reseller.
The current sensor's clamps are not cracked or damaged.	

Inspecting the system

Make sure that . . .	Action
The products are not damaged.	If damage is found, request repair.
The Sense Module displays [EA5302 SENSE MODULE] when turned on.	If [EA5302 SENSE MODULE] is not displayed, there could be damage to the power cord or a product malfunction. Contact your authorized Hioki distributor or reseller.

2.2 Installing the PC Application

- 1 Log in to the PC using an administrator account.
- 2 Exit all running applications on PC.
- 3 Insert the USB flash drive with the EA5700 PC application installer into the PC's USB port.
- 4 Execute the installer [setup_HIOKI_EA5700_ALDAS_V (version No.).exe].

If the User Account Control security feature in Windows requires the user to permit a change:
Select **[Yes]**.

(This window may appear after the installation mode is selected.)

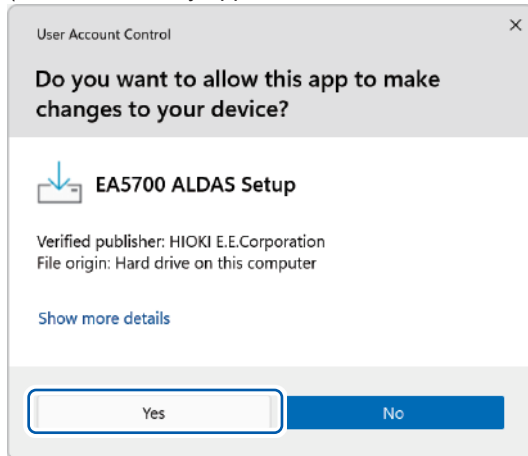

When the installation mode selection screen appears:

Select **[Install for all users]**.

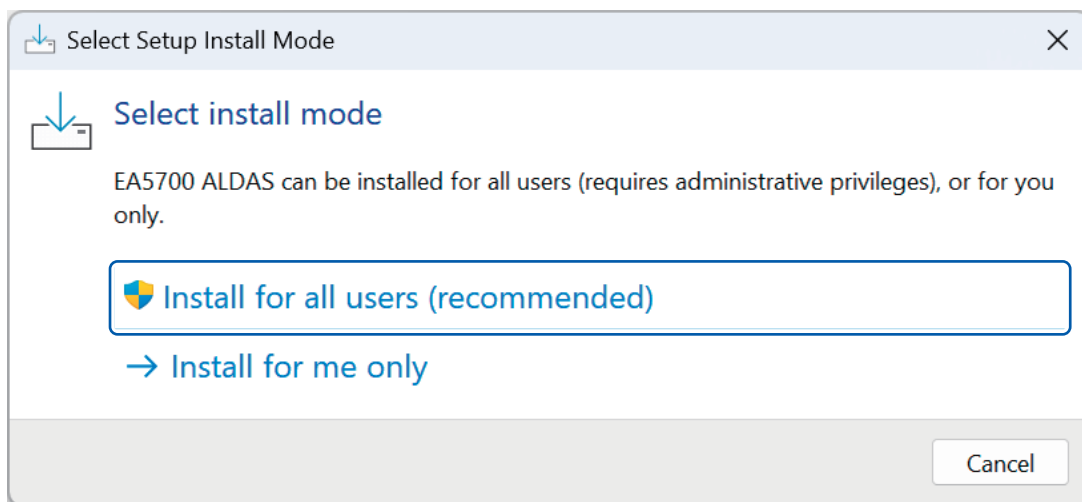

5 Select a language and click **[OK]**.

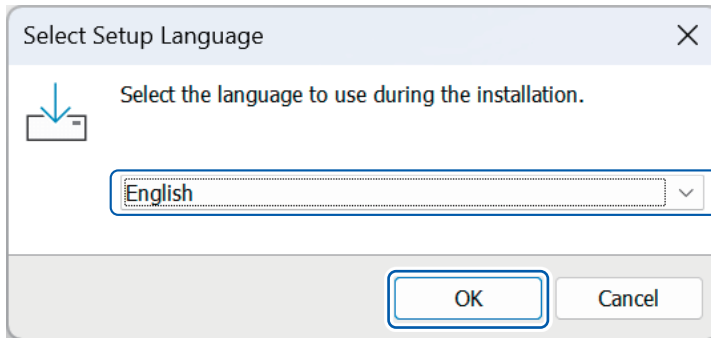

The **[Welcome to the EA5700 ALDAS Setup Wizard]** dialog box will be displayed.

6 Click **[Next]**.

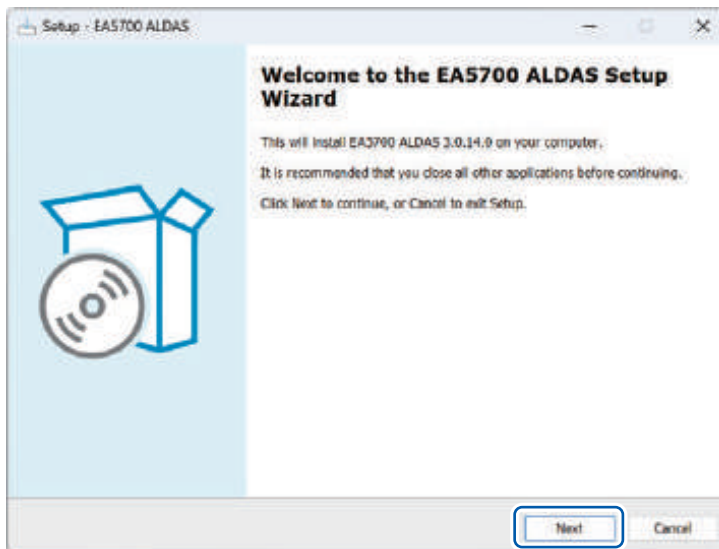

7 Read the **[User's License Agreement]** and select the **[I accept the agreement]** option button. Click **[Next]**.

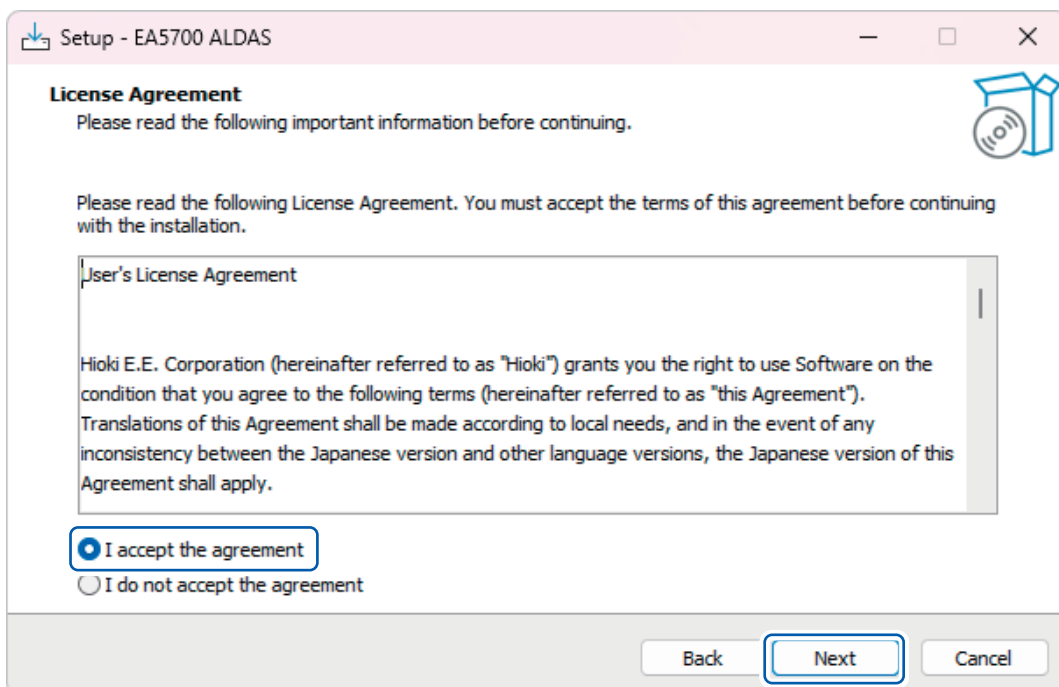

8 Confirm that the **[Create a desktop shortcut]** checkbox is selected and click **[Next]**.

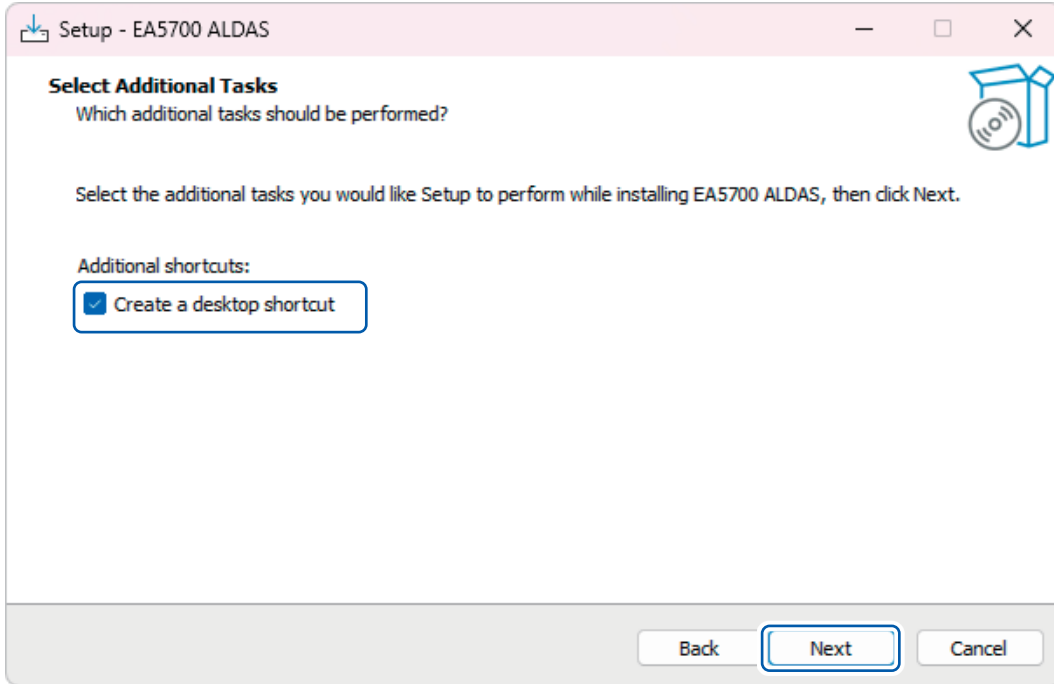

9 Review the information on the dialog box and click **[Install]**.

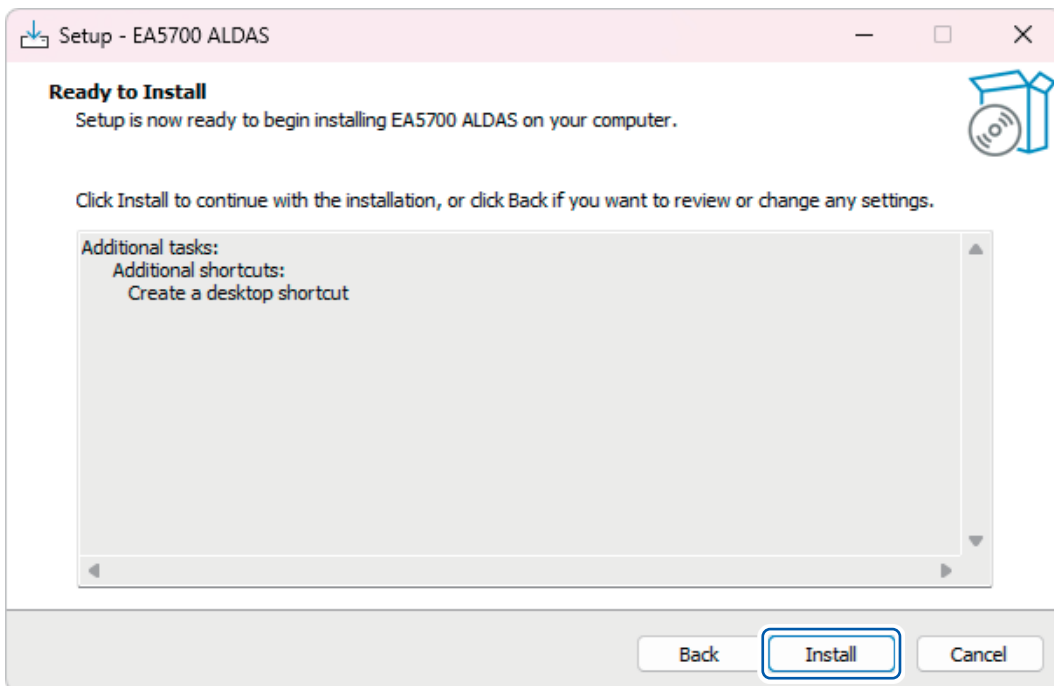

10 Once the installation has completed, click **[Finish]**.

If the **[Launch EA5700 ALDAS]** checkbox is selected, the PC application will start.

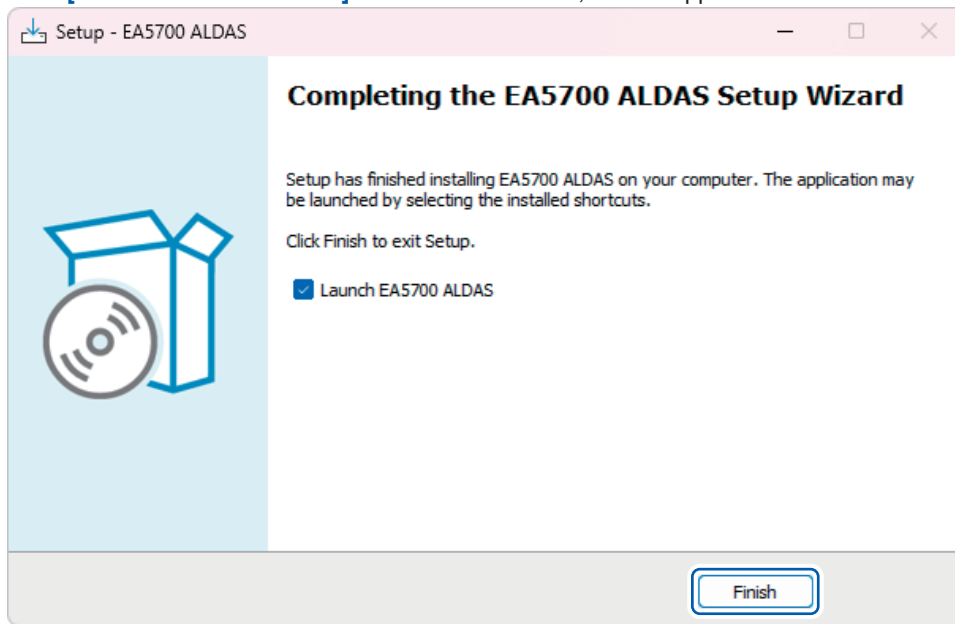

2.3 Setting the IP Address of Each Device

If you purchased the equipment along with the rack cabinet assembled by Hioki, the IP address settings for each device are already set, so no further setup is needed.

However, if additional devices are added afterward, please follow the procedure below to configure the IP address for the new device.

IMPORTANT
 Always configure your LAN settings before connecting to the network. Modifying your LAN settings after connecting to the network can lead to IP address conflicts with other devices or result in invalid address information being transmitted over the LAN.

Configure the IP address of each device according to the following LAN connection diagram and IP setting tables. For LAN connections between each module, see “Connecting the LAN cables” (p.150)

For more information about how to turn on the power to each device, see “2.8 Supplying Power” (p.48).

LAN connection diagram

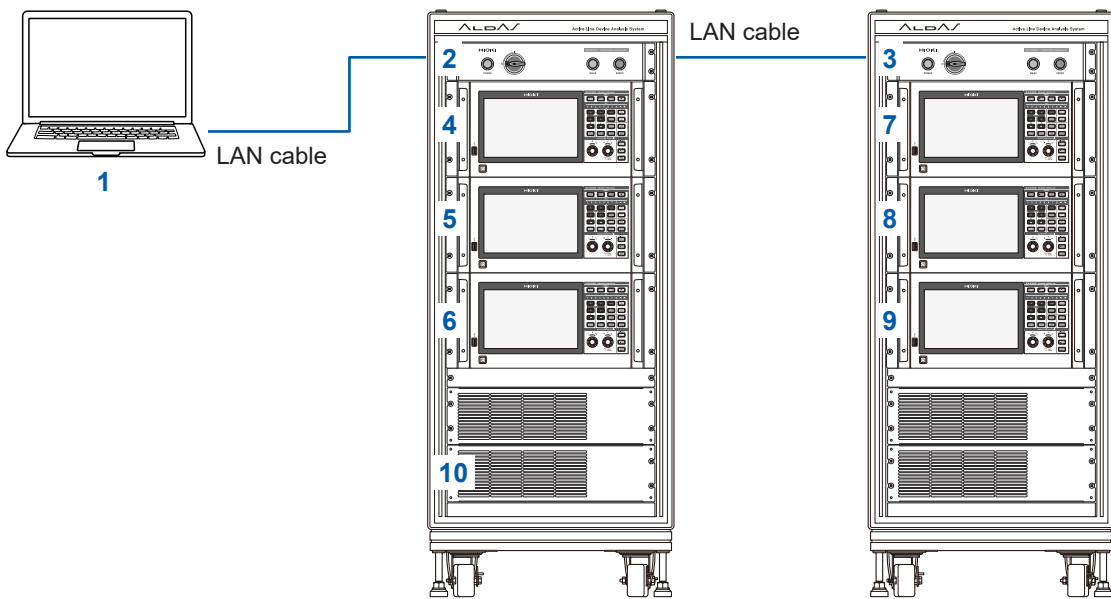

PC

	IP address	Subnet mask	Default gateway
1	192.168.200.200	255.255.0.0	Blank

EA5901 Control Module

Primary

	Display name	IP address	Subnet mask
2	Base IP Address	192.168.201.1	255.255.0.0
	Control Module1	192.168.201.3	255.255.0.0

Secondary

	Display name	IP address	Subnet mask
3	Base IP Address	192.168.202.1	255.255.0.0
	Control Module2	192.168.202.3	255.255.0.0

EA5302 Sense Module

Primary (Constituent units: 1 to 3 modules)

	Display name	IP address	Subnet mask
4	Sense Module 1	192.168.201.4	255.255.0.0
5	Sense Module 2	192.168.201.5	255.255.0.0
6	Sense Module 3	192.168.201.6	255.255.0.0

Secondary (Constituent units: 1 to 3 modules)

	Display name	IP address	Subnet mask
7	Sense Module 4	192.168.202.4	255.255.0.0
8	Sense Module 5	192.168.202.5	255.255.0.0
9	Sense Module 6	192.168.202.6	255.255.0.0

EA5502 Source Module

Primary (Constituent units: 1 or 2 modules)

	Display name	IP address	Subnet mask
10	Source Module	192.168.201.2	255.255.0.0

Setting the IP address of the PC

- 1 Press the Windows key and the R key at the same time.
The [Run] dialog box will be displayed.

- 2 Enter [ncpa.cpl] in the [Open] box and click [OK].

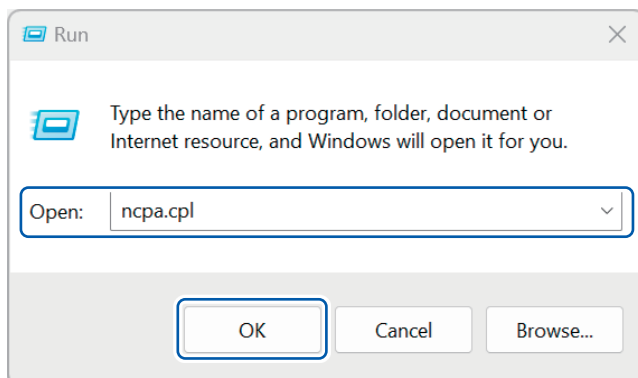

- 3 From the [Network Connections] window, double-click the selected Ethernet port for connecting the PC application with the system.

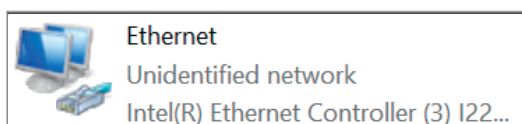

The [Ethernet Properties] dialog box will appear.

- 4 Select the **[Internet Protocol Version 4(TCP/IPv4)]** checkbox and click **[Properties]**.

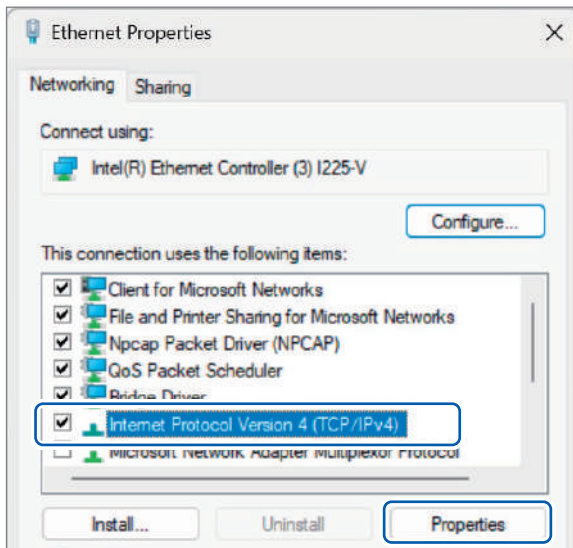

- 5 Set the **[IP address]** to **192.168.200.200**.

The recommended setting range is from 192.168.200.10 to 192.168.200.255.

The following IP addresses cannot be used as they are reserved for the system's operation:
192.168.200.1 to 192.168.200.9

- 6 Set the **[Subnet mask]** setting to **255.255.0.0**.

- 7 Leave the **[Default gateway]** setting blank.

- 8 Click **[OK]**.

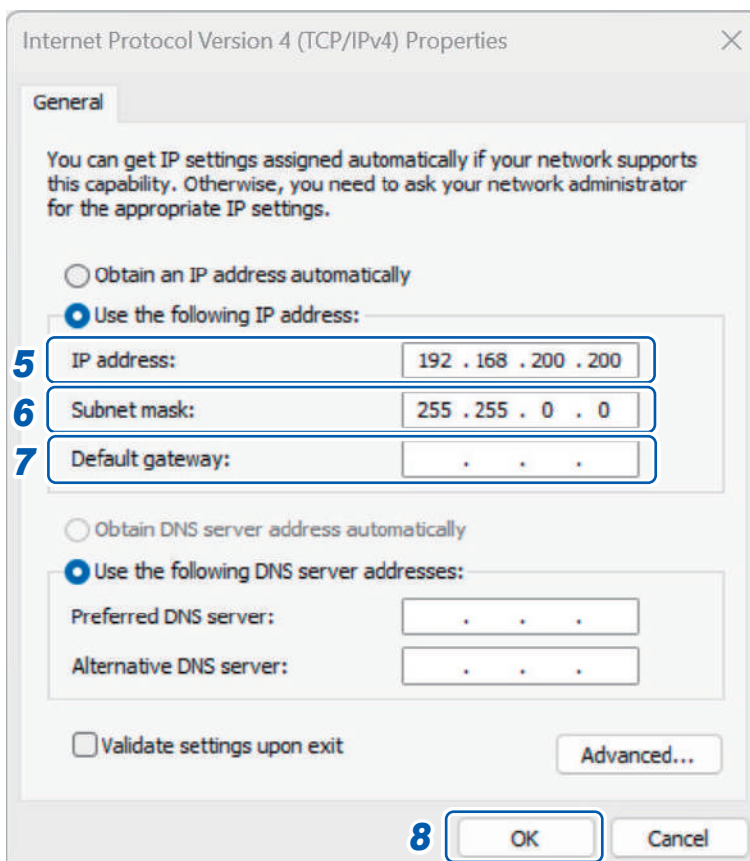

Setting the IP address of the Control Modules (for the second and subsequent modules)

This setting is not needed for a single Control Module (the address is set by default).

1 Set the IP address for the secondary Control Module using the IP setting application.

Download and install the IP setting application from Hioki's website.

See "Information on download site" (p.7).

Refer to the manual included with the application for detailed instructions on how to use it.

Setting the IP address of the Sense Modules (for the second and subsequent modules)

This setting is not needed for a single Sense Module (the address is set by default).

1 Press the **SYSTEM** key on the Sense Module, and then tap **[COM]** option on the screen.

2 Tap the **[DHCP]** box, and then select "OFF".

3 Tap the **[IPv4 address]** box and enter the IPv4 address using the numeric keypad.

This address identifies each individual device connected on the network. Set a unique address to avoid conflicts with other devices.

Set the IP address according to the IP address setting table for the Sense Modules (p. 39).

4 Tap the **[Subnet mask]** box and enter the subnet mask using the numeric keypad.

This setting separates the IP address into the address portion indicating the network and the address portion indicating the device.

Set it to "255.255.0.0".

5 Tap the **[Default gateway]** box and enter the default gateway using the numeric keypad.

Specify the IP address of the device acting as the gateway when the communicating PC and this device are on different networks. Set it to "0.0.0.0".

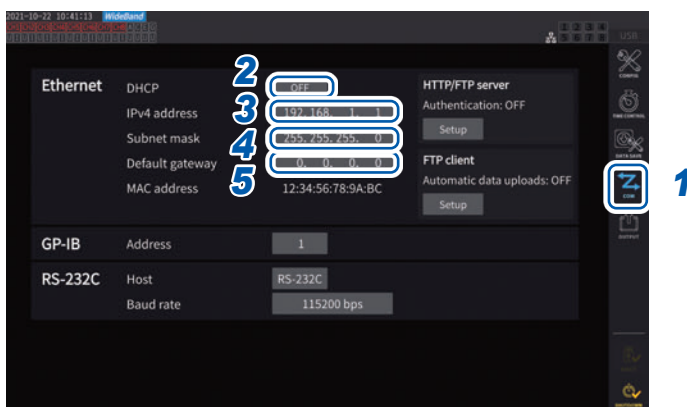

2.4 Connecting the LAN Cables

If the system is not connected to the PC with a LAN cable, connect a LAN cable according to “Connecting the LAN cables” (p.150).

2.5 Connecting the Source Cables

Connect the L1151 Source Cables (optional) to the load input terminals (DC INPUT terminals) on the back of the Source Module.

DANGER

- **Never touch the load input terminals (DC INPUT terminals) while they are energized.**



- **Do not place non-insulating materials within 50 mm of the energized source cable.**

Failure to follow this guidance could cause electric shock or other serious bodily injury or short circuit.

- **Turn off the DC (output) power source of the measurement target before connecting the cords or attaching the terminal covers.**



Failure to follow this guidance could cause electric shock or other serious bodily injury or short circuit.

Arc flash could occur, resulting in serious bodily injury or damage to the system or other equipment.

WARNING

- **Be sure to attach the supplied load input terminal (DC INPUT terminal) cover.**



Failure to follow this guidance could cause electric shock or other serious bodily injury or short circuit.

1 Exit the PC application, and then turn off the DC (output) power source to the measurement target.

2 Turn off the Source Module power.

Power to the Source Module can be turned off by switching OFF the start/stop switch on the Source Module or the main breaker on the EA5901 Control Module.

3 Connect the Source Cables to the load input terminals (DC INPUT terminals) on the back of the Source Module using the supplied load input terminal screw set.

Make sure that the polarity of the load input terminals and the Source Cable is correct.

Source Cable red insulation cap: HIGH (positive electrode)

Source Cable black insulation cap: LOW (negative electrode)

Tightening torque: 22.4 N·m

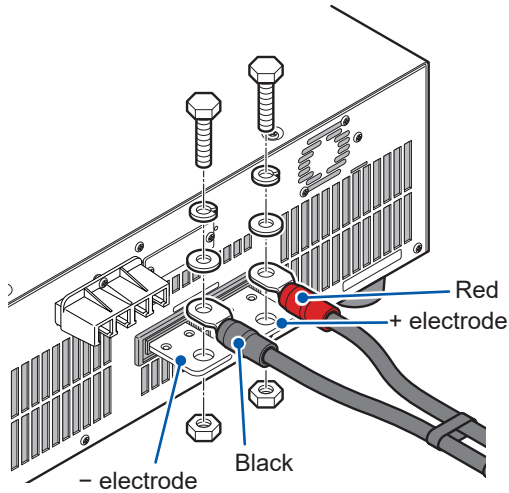

4 Attach the bottom parts of the supplied load input terminal cover below the Source Cables connected to the load input terminals.

5 Align the top part of the cover with the bottom part.



6 Press the cover onto the panel surface and secure it using the supplied screws for the load input terminal cover.

Make sure the screws are securely tightened.

2.6 Connecting the Sense Cables (Voltage Input)

Connect the L1101 Sense Cable (optional) to the voltage input terminals on the rear of the Sense Module.

Connect the necessary number of Sense Cables depending on the number of channels available on your Sense Module and the number of electrolysis cells to be measured.

DANGER



- **Do not short the positive and negative sides of the measurement target (DUT) or the measurement line with the metal part of the Sense Cable clip.**

Failure to follow this guidance will cause an arc flash, resulting in serious bodily injury or damage to the device or other equipment.



- **Turn off the DC power source (output) to the measurement target before connecting the cables.**

Failure to follow this guidance could cause electric shock or other serious bodily injury or short circuit.

Arc flash could occur, resulting in serious bodily injury or damage to the system or other equipment.

WARNING



- **Use only Hioki-specified connection cords with the system.**

Failure to follow this guidance could cause bodily injury or a short circuit. See "Products for current measurement" (p. 10).

IMPORTANT

For accurate measurement, ensure the Sense Cable is firmly and fully inserted.

Rear panel of the Sense Module

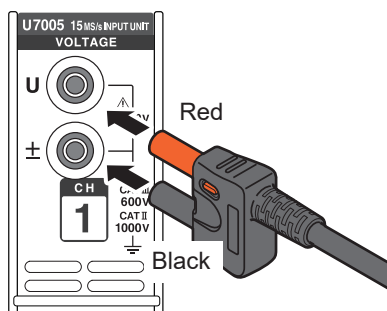

- 1 Insert the Sense Cables into the voltage input terminals.**

Plug the red cable into the "U" terminal, and black cable into the "±" terminal.

2.7 Connecting the Current Sensor (Current Input)

Connect the current sensor to the Probe 1 terminal on the Sense Module.

DANGER

- Do not use the current sensors to measure a circuit carrying a voltage greater than the maximum rated voltage to earth*¹.



- Do not use the current sensors for measuring bare conductors.

Doing so could result in serious bodily injury or a short circuit.

*1. For details about the maximum rated voltage to earth of the current sensor, refer to the instruction manual that came with the current sensor.



- Connect the current sensor to the Probe 1 terminal only.

Using a current sensor other than the option listed in this manual may result in serious personal injury.

CAUTION



- Do not connect or disconnect connectors while the modules have been turned on.

Doing so could damage the sensor.

IMPORTANT

- Do not drop a current sensor onto a floor or other surface.
 - Do not subject the current sensor to mechanical shocks.
- Failure to follow this guidance could adversely affect measurement accuracy and open/close operation

For detailed specifications and instructions for the current sensors being used, refer to the instruction manual that came with the current sensors.

How to plug the connector

IMPORTANT

Always connect the current sensor to CH1 (Probe 1 terminal) only, even when measuring voltage on multiple channels.

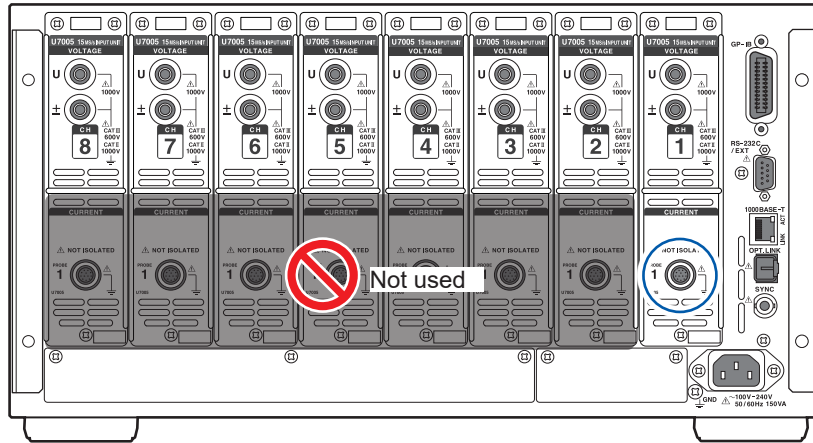

2

Preparing for Measurement

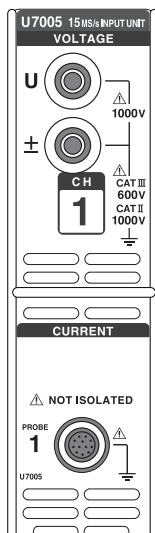

2 Hold the connector with its broader notch facing upward.

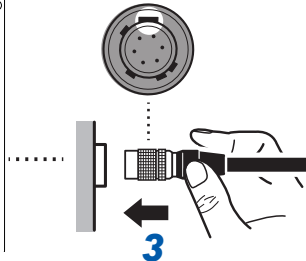

1 Turn off the Sense Module.

2 Align the positions of the connector guides of the Sense Module and the current sensor.

3 Hold the plastic part of the connector and insert it straight until it is locked.

The Sense Module automatically recognizes the type of current sensor when it is plugged in.

How to unplug the connector

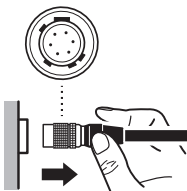

1 Hold the metallic part of the connector and slide it toward the cable side to unlock the connector.

2 Pull out the connector.

2.8 Supplying Power

DANGER



- **Use only the specified power cord to provide power to the system.**

Using a power cord other than the specified part will cause a fire, resulting in serious bodily injury.

WARNING



- **Connect the power cord to a 3-prong grounded-type (2-pole) power outlet.**

Connecting the power cord to an ungrounded power outlet could result in electric shock.

CAUTION



- **Do not power the system with a power supply that generates a rectangular or pseudo-sine wave, such as an uninterruptible power supply (UPS) or DC/AC inverter.**

Doing so could damage the products, resulting in bodily injury. Ensure to use a power supply system with a sine-wave output.



- **Before connecting the power cord to the outlet, verify that the your supply voltage falls within the supply voltage range noted on the AC inlet of the module.**

Supplying a voltage outside the specified range to the product could damage it, causing bodily injury.

- **Ground the ground terminals of the system and the equipment to be connected at a same location.**

Connecting the cable when there is a difference in ground potentials between them could cause damage or malfunction.

Connecting the power cords

Connect the power cords according to “13.3 Connecting the Power Cords and LAN Cables” (p. 148).

- 1** Turn off the power (main breaker) to the Control Module.
- 2** Connect the power cord of each device to the Control Module.
See “13.3 Connecting the Power Cords and LAN Cables” (p. 148).
- 3** Verify that the main power supply voltage falls within the rated range (AC 100 V to 240 V) and connect the included power cord (for the main power supply) to the Control Module’s power inlet.
- 4** Connect the power cord’s plug to main power supply outlet.

Turning on the system

- 1** Confirm that the Source Cables, Sense Cables, and current sensor are all connected.
- 2** After turning on (I) the main breaker of the Control Module, turn on (I) the start/stop switch.
The power is supplied to all the devices connected to the power outlets of the Control Module.
- 3** Let the system warm-up for at least 30 minutes before starting the measurement.

Turning off the system

CAUTION



- Ensure the measurement target’s DC power supply is turned off and the system detects no voltage or current before shutting down the system.

Failure to follow this guidance could damage the device.

- 1** Turn off the measurement target’s DC power supply.
- 2** Verify that there is no voltage or current detected from the measurement target by the Sense Module.
- 3** After turning off (O) the start/stop switch of the Control Module, turn off (O) the main breaker.

When the start/stop switch of the Control Module is turned off, the power supplied to all the devices connected to the power outlets will turn off.

2.9 Zero Adjustment and Degaussing (DMAG)

Zero adjustment is performed for all input channel ranges simultaneously. The current sensor will also be degaussed (DMAG) at the same time. When two or more Sense Modules are installed, perform zero adjustment for all of these Sense Modules.

- 1** Verify that the measurement target is powered off and has no input detected for both voltage and current measurement.
- 2** Press the **MEAS** key (p.26).
- 3** Press the **0ADJ** key (p.26).
- 4** If a confirmation dialog is shown on the Sense Module's display, tap **[Yes]**.

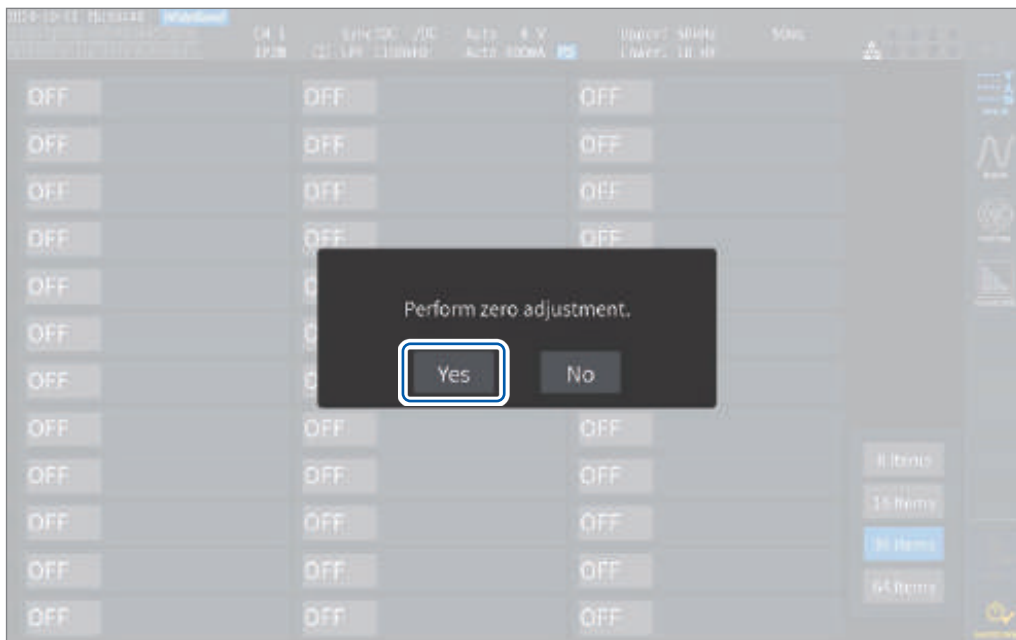

The message **[Performing zero adjustment...]** will be displayed, and zero adjustment will complete in about 30 seconds.

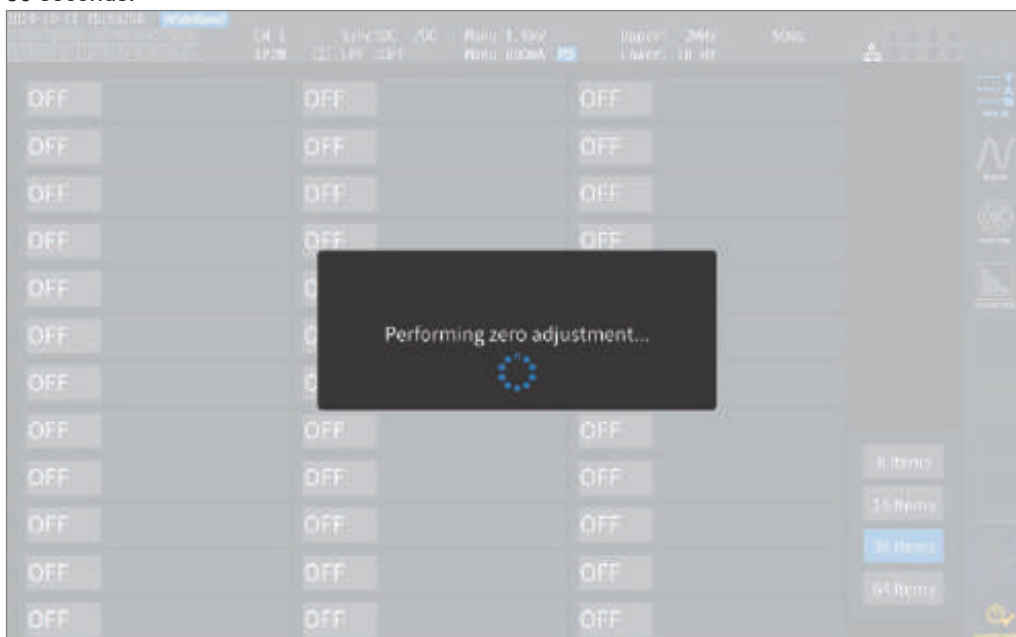

2.10 Connecting to the Measurement Target

Connect the Source Cables, Sense Cables, and current sensor to the measurement target.

⚠ DANGER

- **Do not short the positive and negative measurement lines with the metal part of the Sense Cable clip.**



Failure to follow this guidance will cause an arc flash, resulting in serious bodily injury or damage to the device or other equipment.

- **Never touch the metal areas on test leads or at the tips of voltage cords during measurement.**

Doing so could result in serious bodily injury or a short circuit.



- **Turn off the power supply to the measurement target and measurement line before connecting the Source Cables, Sense Cables, and current sensor.**

Failure to follow this guidance could cause electric shock or other serious bodily injury or short circuit.

⚠ CAUTION



- **Connect the red clip of the Source Cable to the positive terminal (high-potential) and the black clip to the negative terminal (low-potential).**

Connecting the cables with incorrect polarity can cause damage to the Source Module.

Connection Diagram

(1) For single cell

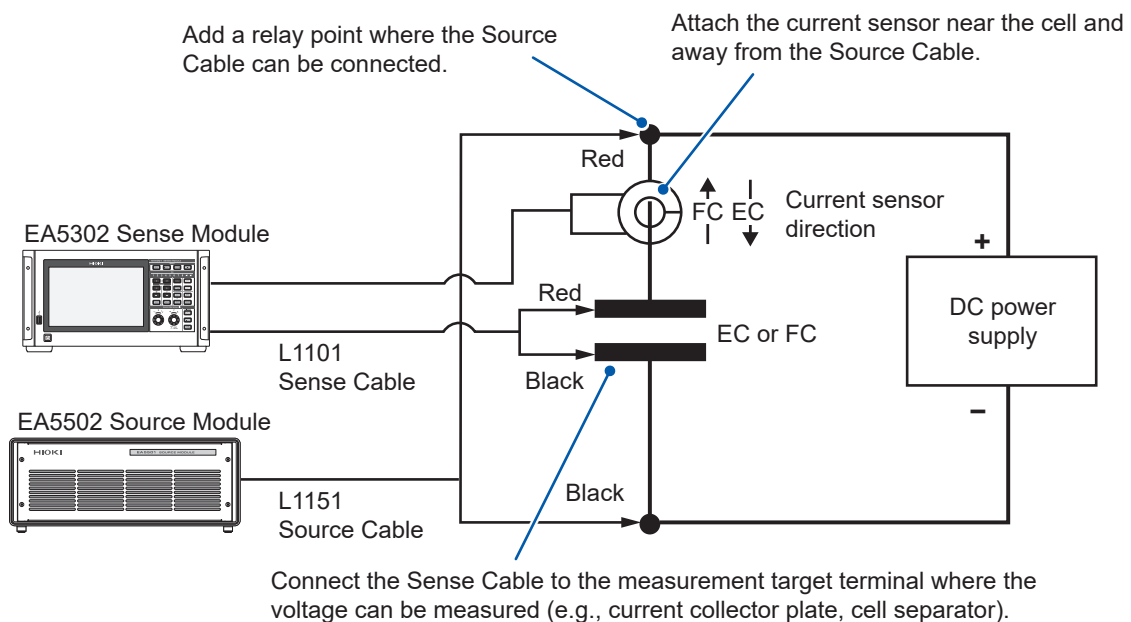

(2) For multiple cells (stack)

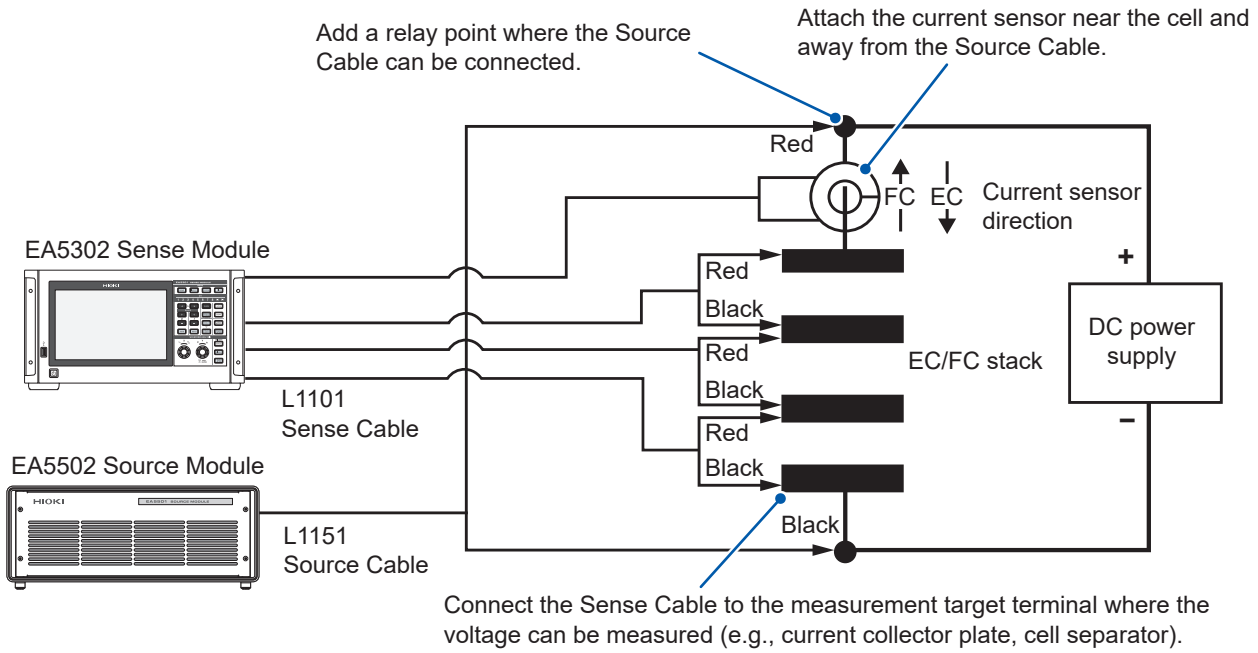

- 1** Turn off the DC power supplies to the DUT and measurement line and then verify that they are completely deenergized.
- 2** Confirm that the measurement system (Sense and Source modules) is turned off.
- 3** Prepare two relay cables with the same length to connect the positive and negative sides of the measurement target to the Source Cables.

The relay cable is not provided with this system. Please prepare a suitable relay cable in compliance with the DC current specification of the measurement target.

Example of a relay cable:  Full length: Approx. 20 cm

4 Clamp the current sensor around the relay cable connected to the DUT.

The clamp type sensor can also be connected after step 5.
Clamp the current sensor around the relay cable (either positive or negative side).
Follow the current sensor's direction depending on the measurement target (DUT) as shown below.

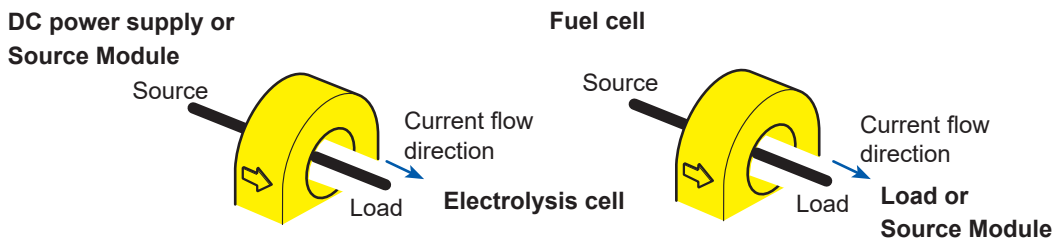

Clamping precautions

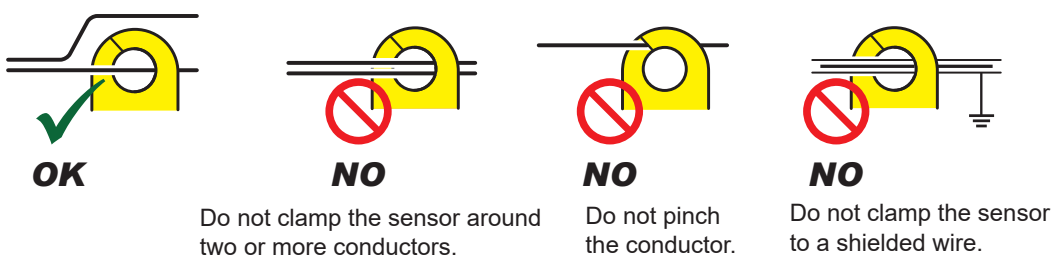

5 Connect the Source Cables to the relay cable and the cable connected with the external DC power supply (or load) using nuts and screws (use the terminal block if there is one).

Connect the terminal of the red insulation cap to the positive terminal (high potential) and that of the black insulation cap to the negative terminal (low potential).

6 Attach the Sense Cable for voltage measurement directly to the terminal of the measurement target.

The closer the Sense Cable terminal is to the measurement target, the more accurately measurement can be performed.

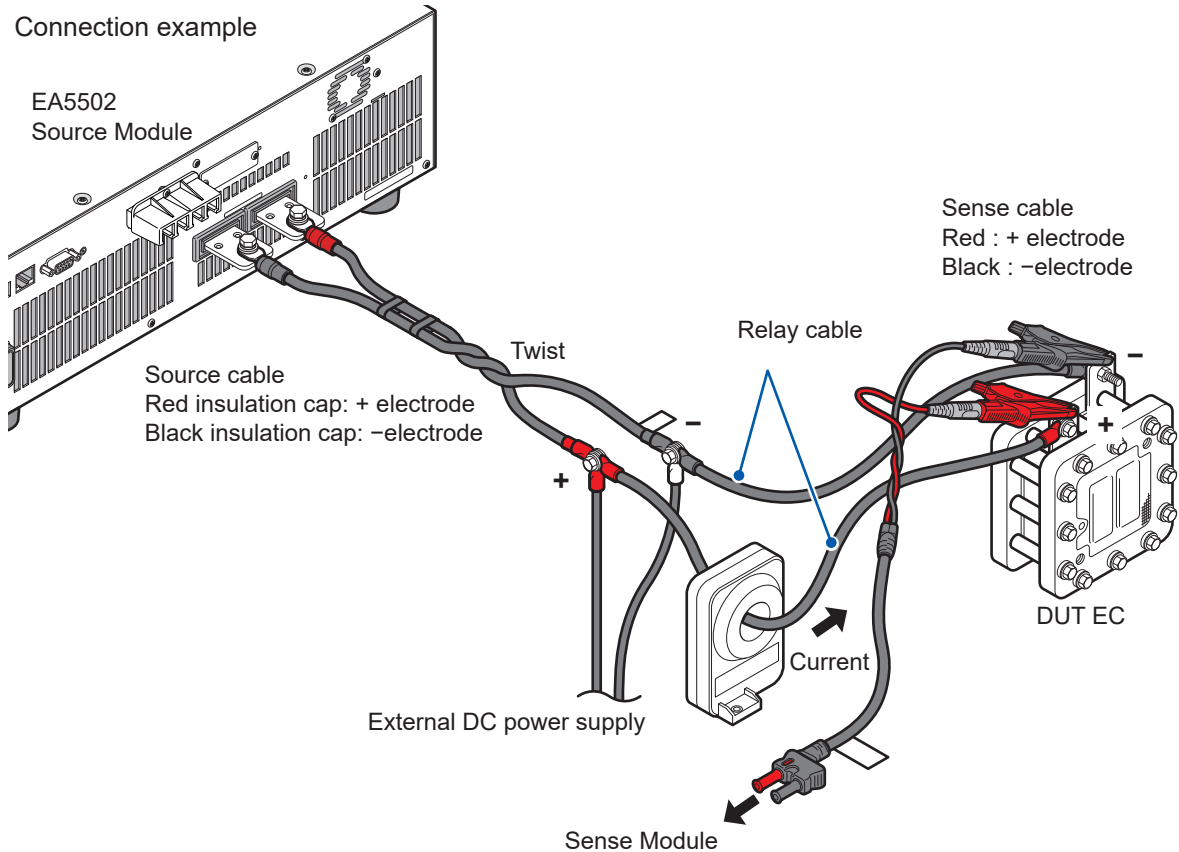

See “Methods for stabilizing measurement” (p. 158).

IMPORTANT

Confirm that the DC (output) power supply voltage of the measurement target is over 10 V (EA5502 specification warranty operation range).

While operation is possible below 10 V (EA5502 actual operating range) by reducing the measurement signal amplitude (current), specifications are not guaranteed. Measurement can become increasingly unstable as the DC power supply (output) voltage of the measurement target falls below 10 V.

See “EA5502 operation range” (p. 119).

3

Configuring the PC Application

3.1 Inserting a USB Dongle Key into the PC

⚠ CAUTION



- **Before handling a USB dongle key, discharge static electricity from your body.**

Application of static electricity could damage the USB dongle key, or cause the system to malfunction. Additionally, the system could fail to start.

IMPORTANT

The Electrolysis Cell Analyzer will perform license authentication when it is launched and starts measurement.

Do not remove the USB dongle key while the application is running.

- 1 **Insert the USB dongle key into the USB port of the PC with the EA5702 Electrolysis Cell Analyzer installed.**

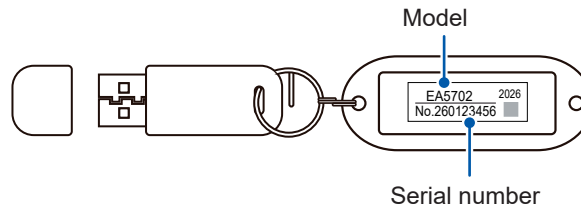

3.2 Launching the EA5702 ALDAS-E PC Application

- 1 **Launch the EA5702 ALDAS-E PC application.**

Launch the application by selecting “HIOKI EA5700 ALDAS” from the desktop icons or application list, or using the search box. After USB dongle key authentication, the PC application launches as “EA5702 ALDAS-E”.

If the USB dongle key is not inserted when launching the application, the following screen will appear. Click **[OK]** to exit the application and then restart the application after inserting the USB dongle key.

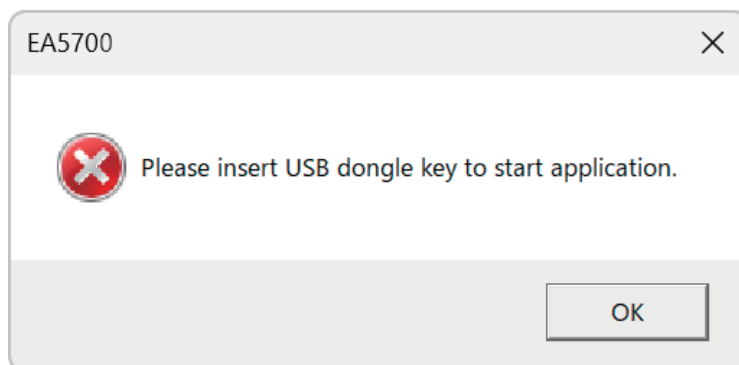

3.3 Creating a Measurement Project

A measurement project's file consists of measurement conditions, hardware information, measurement target information and measurement results. Opening the project file [**ProjectName.aldasproj**], you can restore and load information such as the previous measurement results and setting conditions. Follow the steps below to create a measurement project.

1 Click [**New**] in the [**HOME**] tab.

[**Project Settings**] window will be displayed.

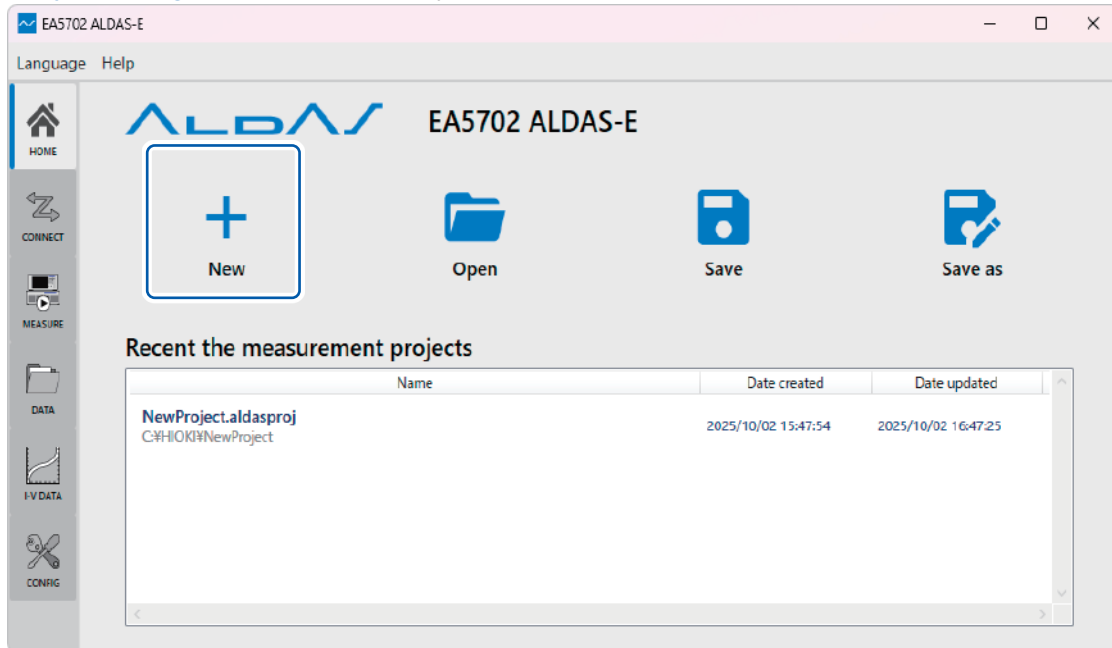

2 Click [**Browse**] to select the location to save the project file.

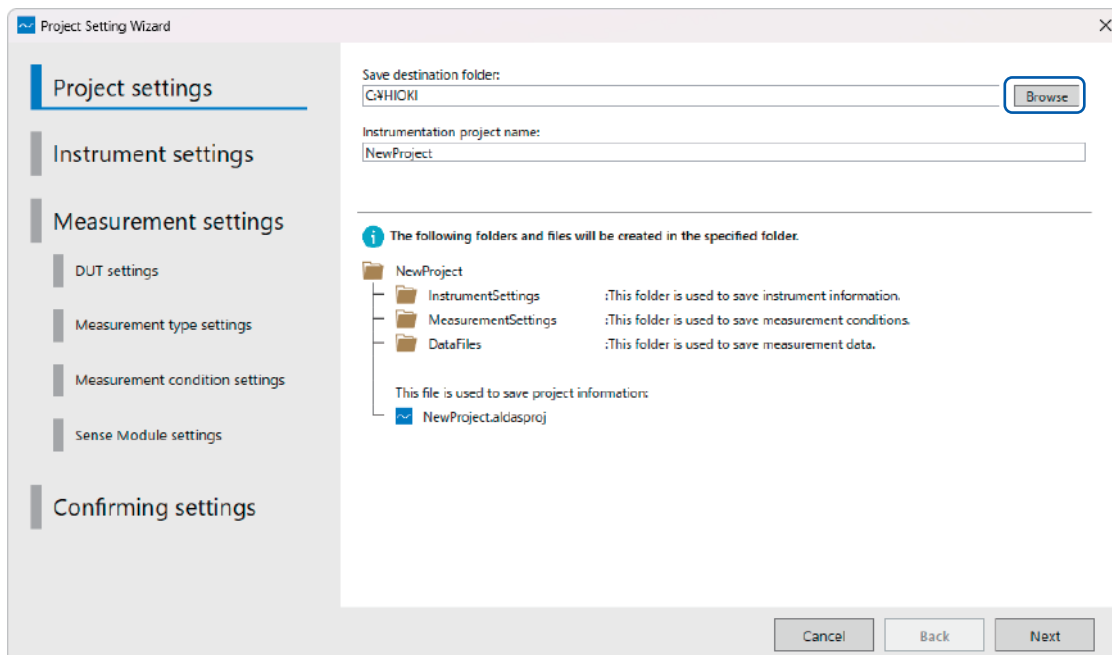

3 Click [Select Folder].

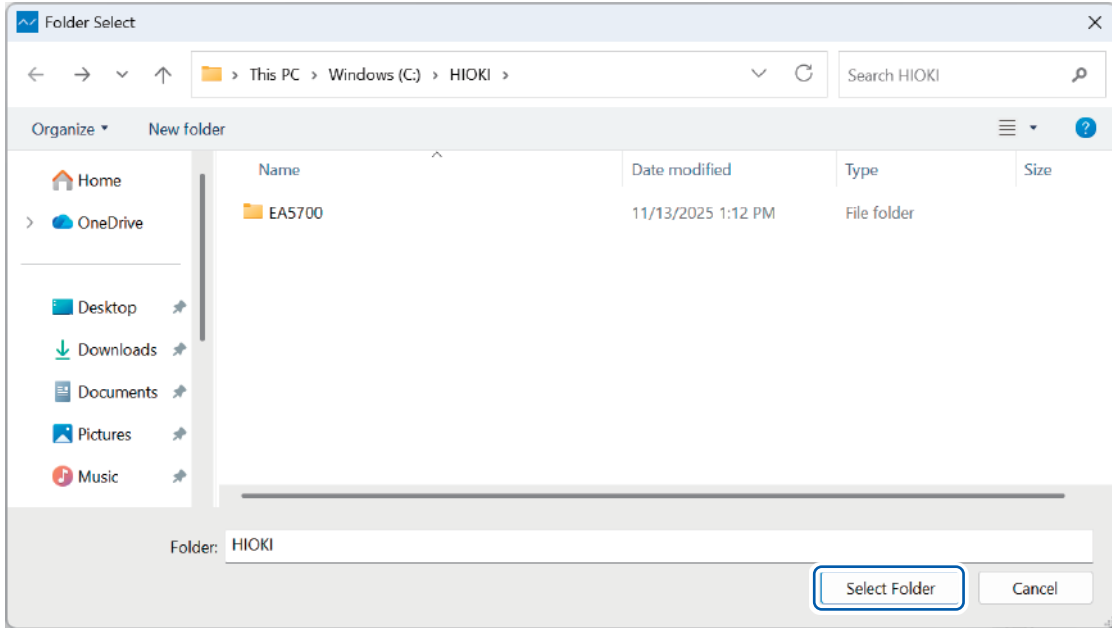

4 Specify the project name in the [Instrumentation project name] text box.

An error will be displayed if a project folder with the same name already exists in the specified directory. Specify a different name.

5 Click [Next].

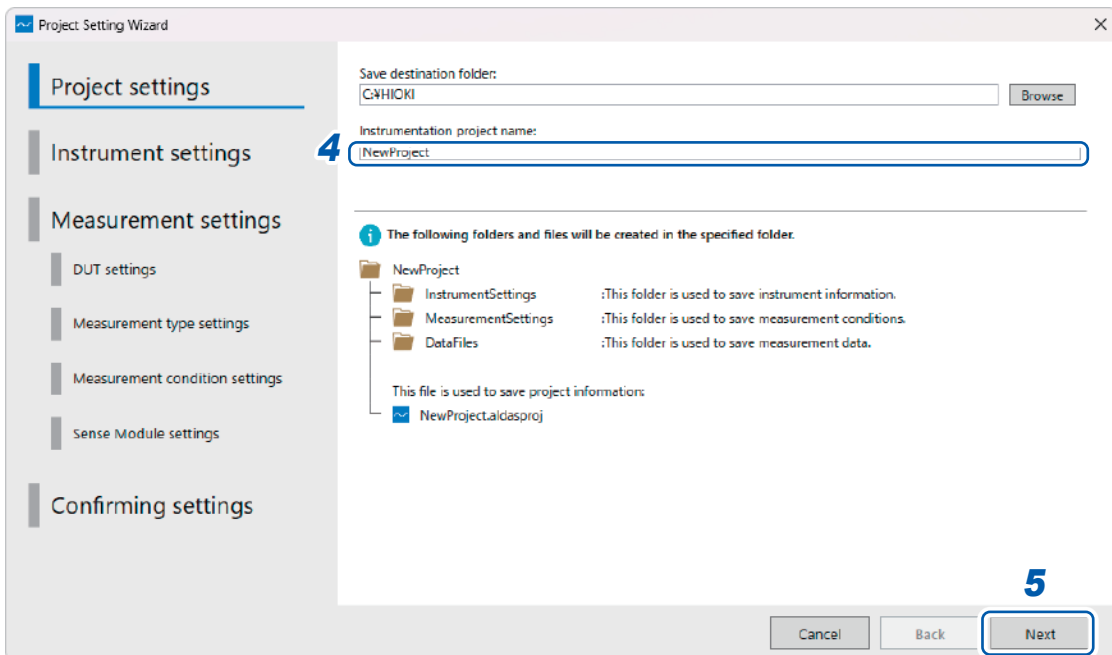

3.4 Setting the System Configuration (Communication Connection with the System)

The PC environment needs to be set up to connect and communicate with the system instruments, which include the Sense Module (equipped with a current sensor and Sense Cables) and Source Module (equipped with a Source Cable), that are involved in the measurement process.

If the initial configuration has been completed

A message indicating that the connection is successful will be displayed. Click **[Next]** and proceed to “3.5 Setting the Measurement Method” (p.60).

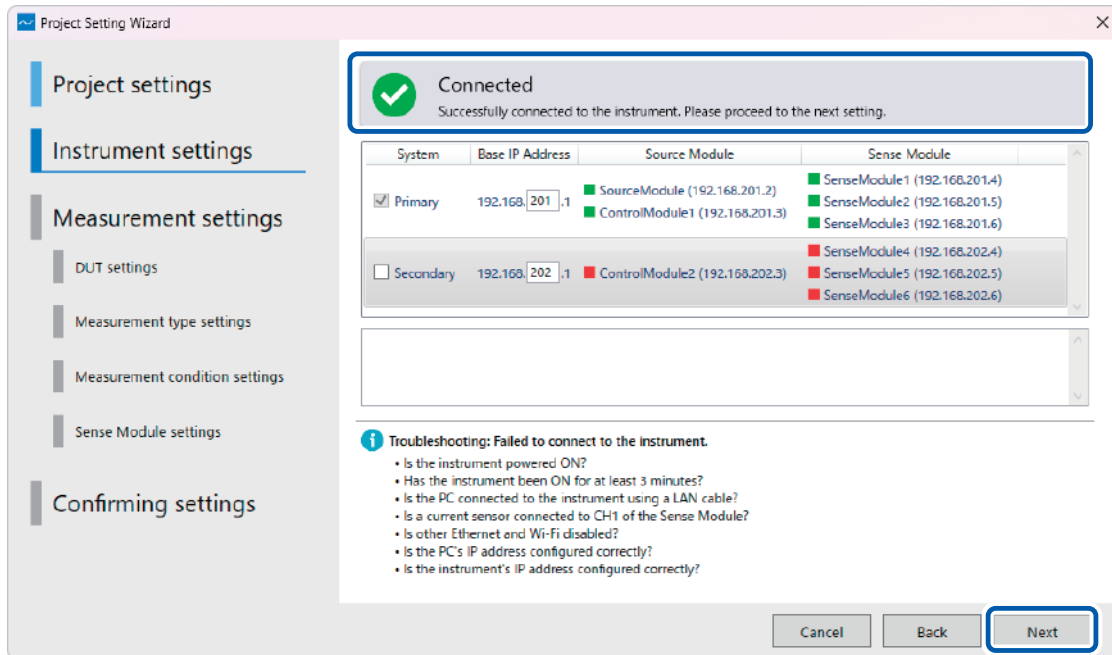

IMPORTANT

It takes at least three minutes to warm-up the Control Module.

If connection with the system failed:

A message indicating that the PC application failed to connect to the measurement system will be displayed.

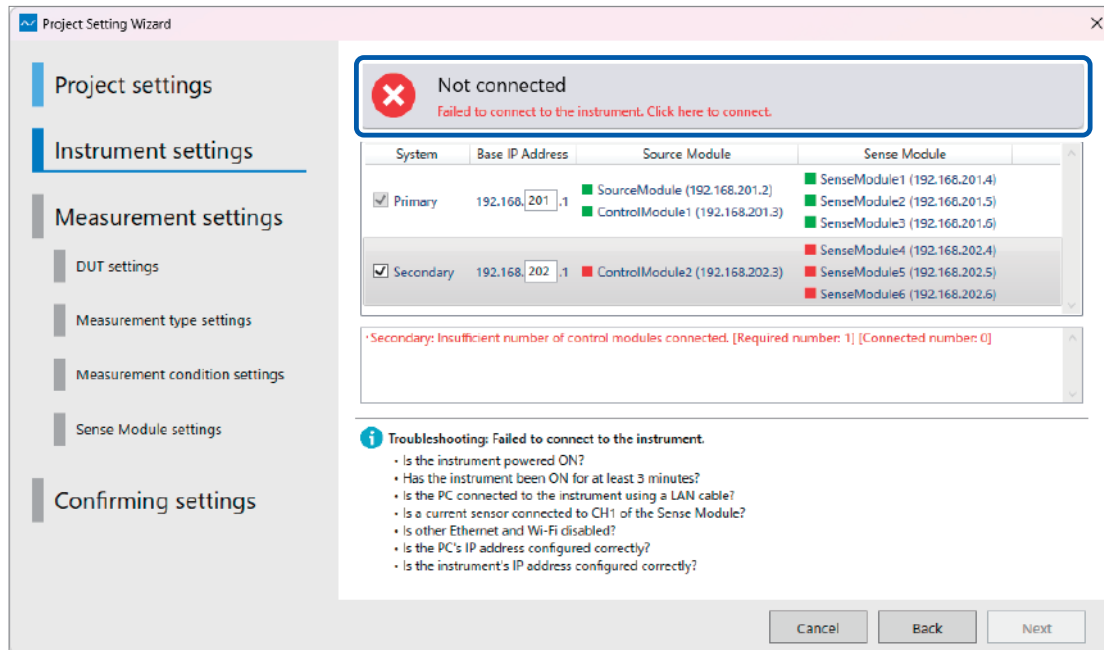

IMPORTANT

If you are having trouble with the connections, please check the following troubleshooting points:

- Is the instrument powered ON?
- Has the instrument been ON for at least 3 minutes?
- Is the PC connected to the instrument using a LAN cable?
- Is a current sensor connected to CH1 of the Sense Module?
- Is the PC's IP address configured correctly?
- Is the instrument's IP address configured correctly?

1 Check the conditions stated in "IMPORTANT" again, and then click [Not connected].

If the settings have been configured properly, a message indicating that the connection is successful will be displayed.

2 Click [Next].

Proceed to "3.5 Setting the Measurement Method" (p.60).

3.5 Setting the Measurement Method

This section provides guidance on how to set the measurement target, measurement conditions, as well as settings for the Source and Sense Module.

Setting the measurement target (DUT)

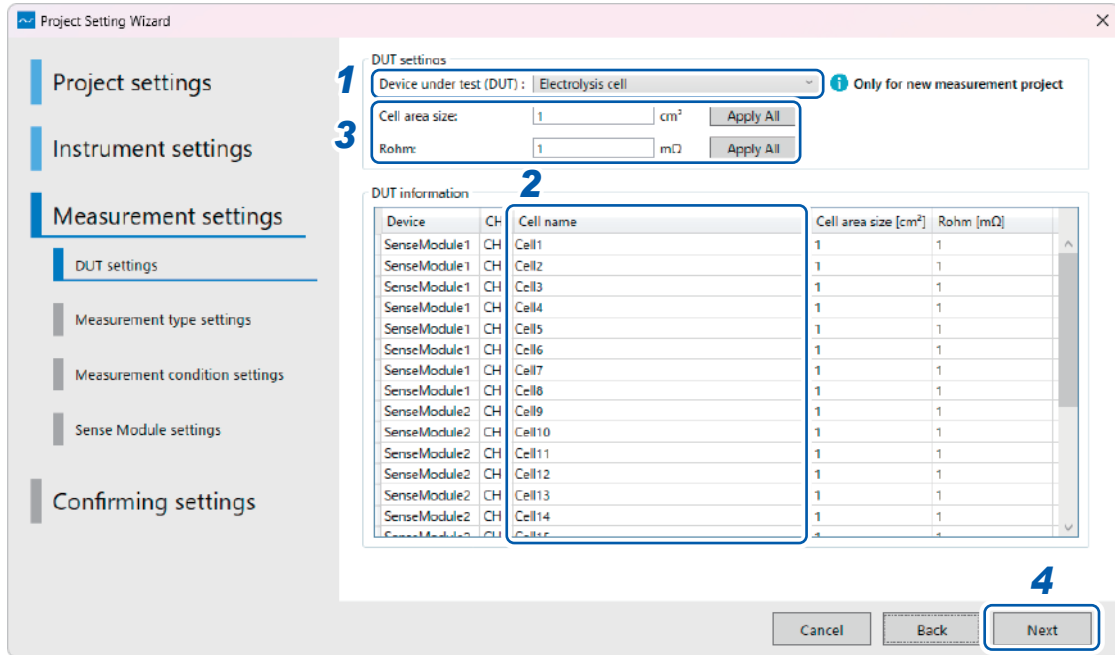

1 (When creating a new project file) Select **[Device under test (DUT)]**.

Electrolysis cell	EC: Electrolysis Cell
Fuel cell	FC: Fuel Cell

To change the measurement target (DUT), create a new project file.

2 Enter the name in **[Cell name]**.

The assigned name here will be shown in the graph legend. For the I-V graph, each cell name will have its own respective I-V plot. Multiple cells will result in multiple I-V curves on the same graph.

3 Enter values in **[Cell area size]** and **[Rohm]**.

Cell area size	By default, the cell size area size is set to “1”, but you can modify this value. The cell area size value is used to calculate the cell’s performance display in the I-V graph with current density. Specify “1”, which is the default value, in the following cases: <ul style="list-style-type: none"> • The current density display is not selected • The parameters are unknown • The parameter of the cell area size, etc. is not applicable to the measurement target
Rohm	Specifies the cell’s ohmic resistance. This value is used to calculate IRfree plots. If no value is specified, the default value is 1 mΩ.

4 Click **[Next]**.

The measurement method settings window will be displayed.

Setting the measurement method

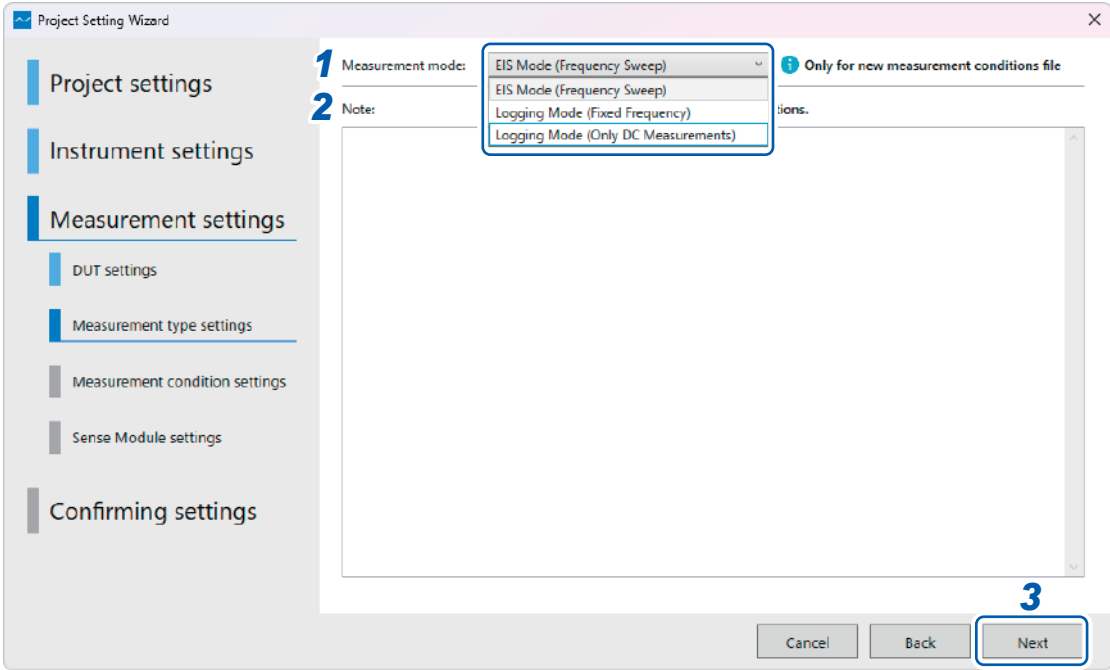

1 Select [Measurement mode].

IMPORTANT
 If the PC goes into sleep mode during measurement, the measurement will stop. Please check your PC's power settings beforehand.

EIS Mode (Frequency Sweep)	Measures impedance while sweeping through a range of frequencies.
Logging Mode (Fixed Frequency)	Measures impedance continuously according to the specified frequency and measurement interval.
Logging Mode (Only DC Measurements)	Measures the DC voltage and current continuously according to the specified interval.

2 Enter any text in [Note].

You can enter and save the measurement conditions and other necessary notes as text and link them with the measurement data.

3 Click [Next].

The measurement conditions settings window will be displayed according to the measurement mode selected.
 "Setting the measurement conditions: EIS Mode (Frequency Sweep)" (p.62)
 "Setting the measurement conditions: Logging Mode (Fixed Frequency)" (p.64)
 "Setting the measurement conditions: Logging Mode (Only DC Measurements)" (p.66)

Setting the measurement conditions: EIS Mode (Frequency Sweep)

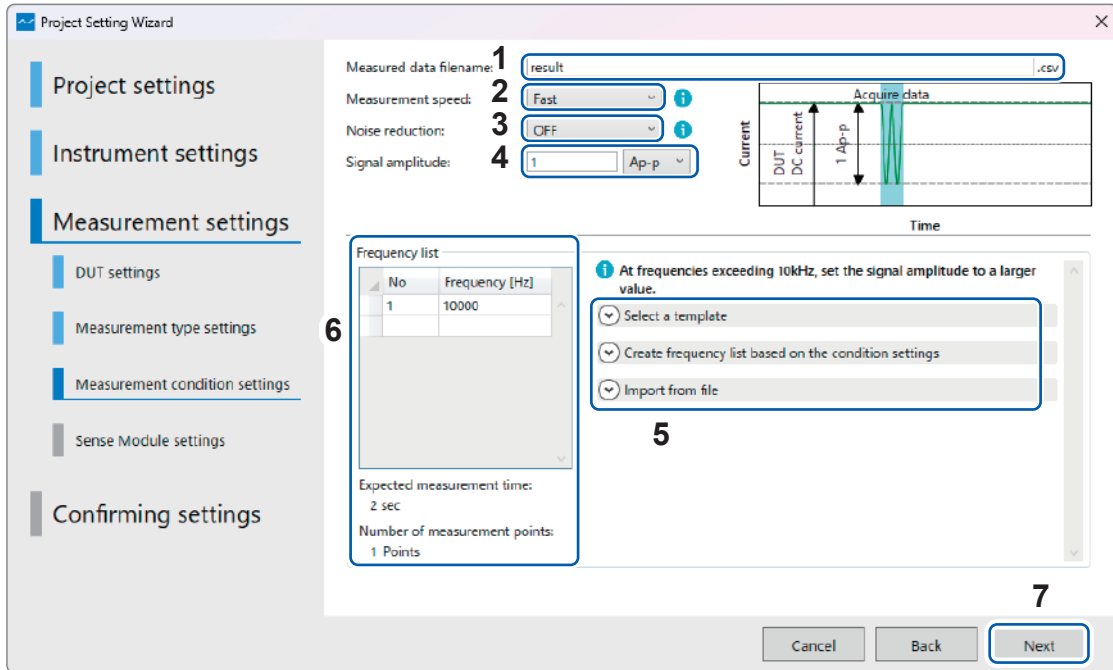

No.	Setting item	Description
1	Measured data filename	Specify the name of the measurement result file to be saved. The file will be saved in the [DataFiles] folder in the project folder. If a file with the same name exists in the [DataFiles] folder, an incremented number will be appended to the end of the filename, for example [Filename_1.csv].
2	Measurement speed	Select the speed from [Fast], [Medium], and [Slow].
		[Fast] The measurement speed takes precedence over stability. This measurement speed yields the least stable results among all the others.
		[Medium] The measurement process ensures a balance between measurement speed and measurement stability.
3	Noise reduction	[Slow] Priority is given to the measurement stability when taking measurements. As the number of measurements increases, the measurement speed slows down compared to other modes.
		[OFF] Disables noise reduction.
		[ON] Reduces the noise generated at frequencies higher than the measurement signal frequency.

No.	Setting item	Description
4	Signal amplitude	<p>Set the amplitude of the measurement signal by selecting either peak-to-peak or RMS current.</p> <div style="border: 1px solid #00AEEF; padding: 5px;"> <p>IMPORTANT</p> <p>Set the measurement signal amplitude according to the measurement target specifications. Start with the amplitude value at around 5% of the measurement target DC current value. Setting the amplitude too small will result in an unstable impedance measurement. Setting the amplitude too large will cause the measurement target current to fluctuate significantly due to the applied measurement signal. See "Impedance measurement during DC operation" (p.155).</p> </div>
5	Frequency list generation method	<p>Select the method for generating a test frequency list.</p> <p>[Select a template] Select frequency range template via drop down menu. Conditions will be registered in the frequency list when they are selected from the combo box.</p> <p>[Create frequency list based on the condition settings] Generate the frequency list by specifying parameters such as start frequency, end frequency, and number of points. The conditions will be registered in the frequency list when you click the [Create] button after configuring the settings.</p> <p>[Import from file] Load the frequency list from a CSV file. When you click [Browse] and select a file, the measurement signal's frequencies will be loaded and registered in the frequency list. CSV files must satisfy the following conditions:</p> <ul style="list-style-type: none"> • Each frequency value must be separated by a newline codes. • Frequency values must be within the range of 0.01 Hz to 100000 Hz. • Frequency values must have no more than two significant figures. Example: 1200 Hz satisfies the conditions, but 1230 Hz does not. <p>If a value does not satisfy the conditions, it will be converted automatically to the nearest two significant figures value.</p>
6	Frequency list (Edit as necessary)	<p>Perform measurement at the frequencies displayed in [Frequency list]. Double-click each number in the [Frequency] column to change the measurement signal frequency.</p> <p>For more information about the resolution at which frequencies can be set, see "Impedance measurement frequency resolution" (p.109) in the specifications.</p> <p>The [Expected measurement time] and [Number of measurement points] will be displayed underneath the list. Measurement time can vary depending on the measurement conditions. Use this information as a guide when creating conditions.</p> <p>Noted that the maximum number of measurement points is 1000.</p>
7	Next	<p>The Sense Module setting window (p.67) is displayed.</p>

Setting the measurement conditions: Logging Mode (Fixed Frequency)

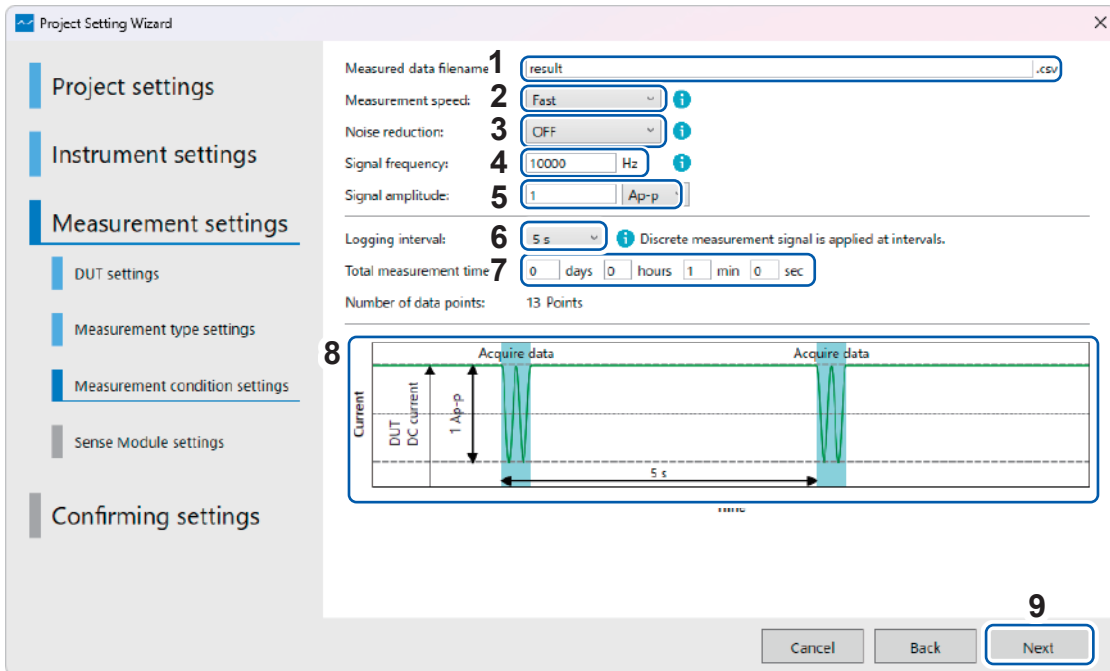

No.	Setting item	Description
1	Measured data filename	Specify the name of the measurement result file to be saved. The file will be saved in the [DataFiles] folder in the project folder. If a file with the same name exists in the [DataFiles] folder, an incremented number will be appended to the end of the filename, for example [Filename_1.csv].
2	Measurement speed	Select the speed from [Fast], [Medium], and [Slow].
		[Fast] The measurement speed takes precedence over stability. This measurement speed yields the least stable results among all the others.
		[Medium] The measurement process ensures a balance between measurement speed and measurement stability.
3	Noise reduction	[Slow] Priority is given to the measurement stability when taking measurements. As the number of measurements increases, the measurement speed slows down compared to other modes.
		[OFF] Disables noise reduction.
		[ON] Reduces the noise generated at frequencies higher than the measurement signal frequency.
4	Signal frequency	Specify the measurement signal frequency.

No.	Setting item	Description
5	Signal amplitude	<p>Set the amplitude of the measurement signal by selecting either peak-to-peak or RMS current.</p> <div style="border: 1px solid black; padding: 5px;"> <p>IMPORTANT</p> <p>Set the measurement signal amplitude according to the measurement target specifications. Start with the amplitude value at around 5% of the measurement target DC current value. Setting the amplitude too small will result in an unstable impedance measurement. Setting the amplitude too large will cause the measurement target current to fluctuate significantly due to the applied measurement signal. See "Impedance measurement during DC operation" (p. 155).</p> </div>
6	Logging interval	Select the data acquisition interval for each measurement.
7	Total measurement time	Specify the total time until measurement is completed. Set the time so that the number of measurements will be 5000 (Points) or less.
8	Current waveform during signal superposition	<p>This is a diagram that shows the current flowing to the cell during signal superposition. The horizontal axis indicates the time, while the vertical axis indicates the current value.</p> <p>The graph changes when the user inputs signal frequency, signal amplitude, logging interval, and speed.</p> <p>In the Logging Mode, impedance is measured by performing signal superposition at the logging interval. The DC voltage and current are measured immediately before the signal superposition. The continuous measurement signal is applied when there is short intervals between the measurements. In this case, the DC voltage and DC current is recorded only at the beginning of the measurement.</p>
9	Next	The Sense Module setting window (p.67) is displayed.

Setting the measurement conditions: Logging Mode (Only DC Measurements)

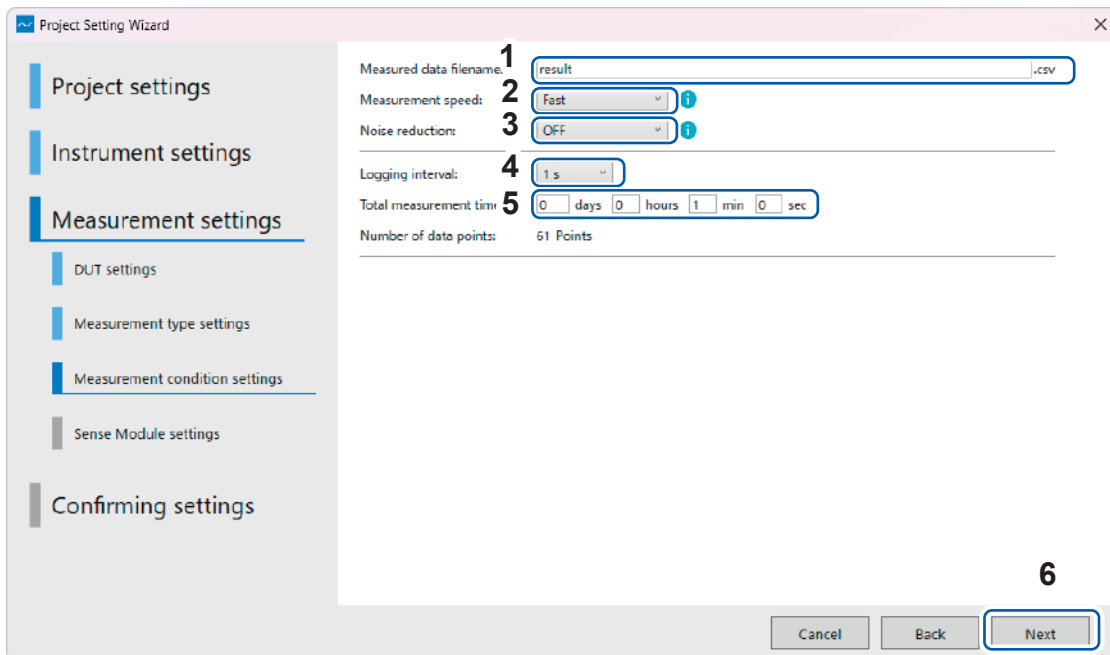

No.	Setting item	Description
1	Measured data filename	Specify the name of the measurement result file to be saved. The file will be saved in the [DataFiles] folder in the project folder. If a file with the same name exists in the [DataFiles] folder, an incremented number will be appended to the end of the filename, for example [Filename_1.csv] .
2	Measurement speed	Select the speed from [Fast] , [Medium] , and [Slow] .
		[Fast] The measurement speed takes precedence over stability. This measurement speed yields the least stable results among all the others.
		[Medium] The measurement process ensures a balance between measurement speed and measurement stability.
3	Noise reduction	[Slow] Priority is given to the measurement stability when taking measurements. As the number of measurements increases, the measurement speed slows down compared to other modes.
		Select the filter for suppressing noise.
		[OFF] Disables noise reduction.
4	Logging interval	[ON] Reduces the noise generated at frequencies higher than the measurement signal frequency.
		Select the data acquisition interval for each measurement.
5	Total measurement time	Specify the total time until measurement is completed. Set the time so that the number of measurements will be 5000 (Points) or less.
6	Next	The Sense Module setting window (p.67) is displayed.

Configuring the Sense Module

A Sense Module settings window will be displayed according to the type of Sense Module connected in “3.4 Setting the System Configuration (Communication Connection with the System)” (p.58).

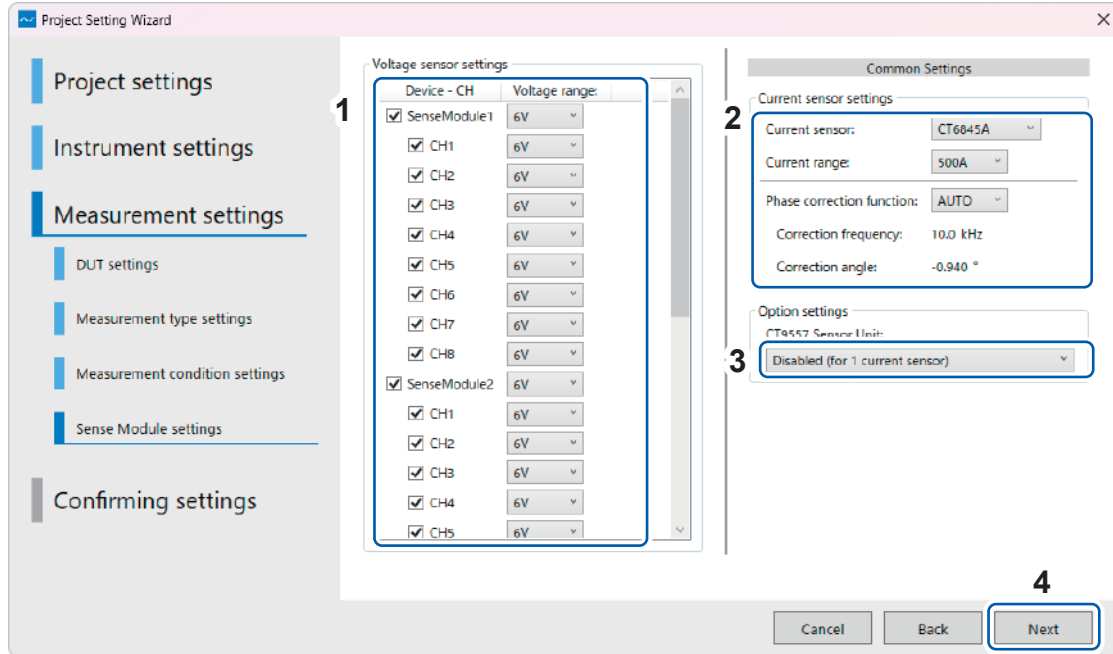

3

Configuring the PC Application

No.	Setting item	Description	
1	Voltage sensor settings	Checkboxes	Select the checkboxes of the channels to be used.
		Voltage range	The voltage range must be set larger than the measurement target's load voltage.
2	Current sensor settings	Current sensor	Displays the model name of the currently connected current sensor. See “2.7 Connecting the Current Sensor (Current Input)” (p.46). When the Z5405 Sensor Branch Module is used, select the current sensor connected to the module from the options.
		Current range	The current range must be set larger than the DUT's load current.
		Phase correction function	[AUTO] Uses the correction value registered for each sensor. [OFF] Disables phase correction.
3	Option settings CT9557 Sensor Unit	When the CT9557 Sensor Unit is used, enable the unit and select the number of sensors connected to the sensor unit.	
4	Next	Displays a window for confirming the settings (p.68).	

3.6 Confirming the Settings

1 Confirm the settings.

Confirm the settings of the measurement project to be created.

2 Click [Complete].

Creation of the measurement project is completed and the project is then saved. After that, the main application window is displayed.

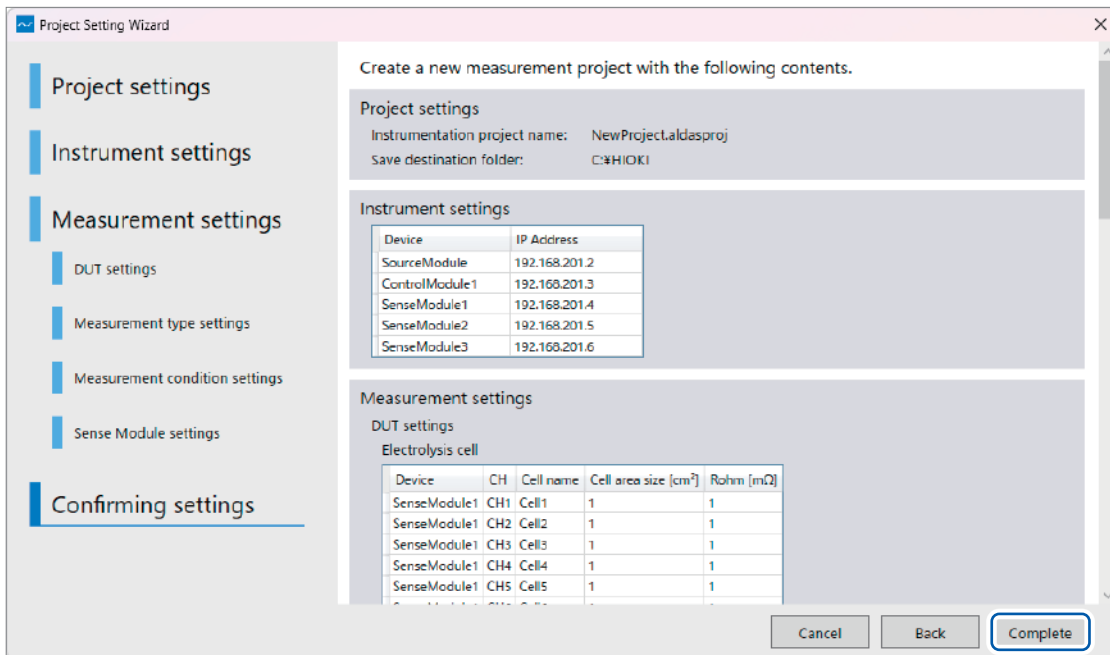





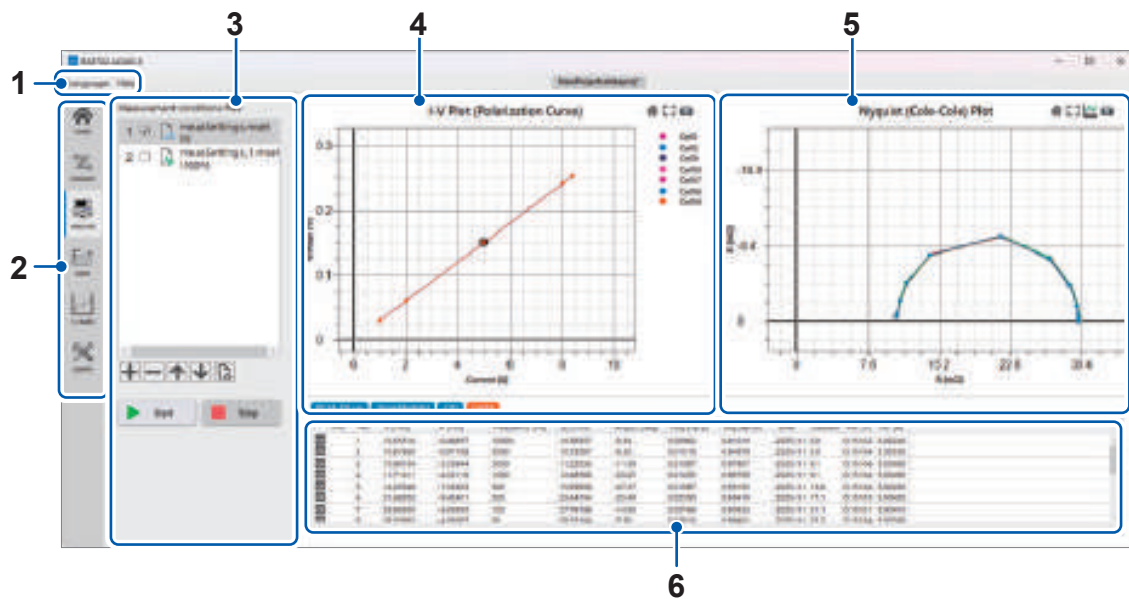

3.7 Description of Main Application Window

The main application window will be displayed after completing the measurement setup.



3

Configuring the PC Application

1	Menu bar	Language	The application language can be changed and selected here.	
		Help	The Help menu contains the application information and the instruction manual.	
2	Tab list		Home	Displays windows to create, save, and open project files.
			Connection settings	Displays the connection status button and system information.
			Measurement settings	Displays a list of measurement condition files, measurement start and stop buttons, and measurement progress.
			Measurement data	Displays the data file list.
			I-V data	Displays the I-V data list.
			Configuration settings	Display graph and data table settings.
3	Side menu	Displays settings for the function selected in the tab list.		
4	I-V graph	A graph that represents the relationship between current (or current density) and voltage.		
5	Impedance graph	A graph that indicates the impedance characteristics.		
6	Data table	Displays detailed measurement data from the selected file in a table.		

3.8 Checking the Folders and Files of the Measurement Project

Confirm that the following folders and files have been generated in the directory you specified in “3.3 Creating a Measurement Project” (p.56).

[Specified project name] directory

- [DataFiles] directory
- [InstrumentSettings] directory
- [MeasurementSettings] directory
- [Specified project name.aldasproj] project file

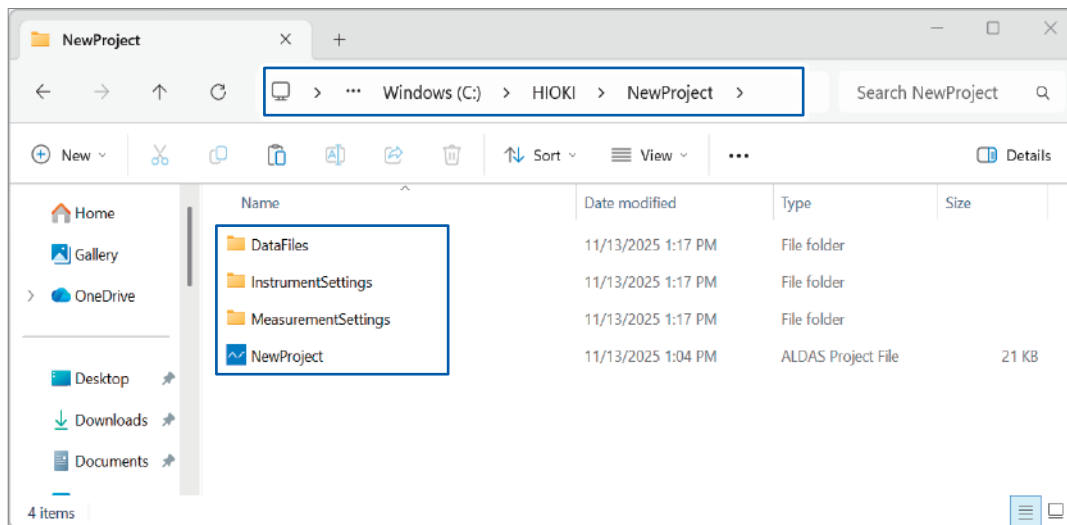

4

Making Measurements

4.1 Starting/Stopping the Measurement and Checking the Progress

1 Click the Measurement settings ([MEASURE]) tab.

2 Click [Start].

Measurement starts according to the set conditions, and the window automatically switches to the Measurement data ([DATA]) tab.

Measurement stops automatically once the final data point in the measurement condition file is acquired.

To forcibly stop the measurement, click [Stop].

3 Check the current measurement conditions and measurement progress in the measurement status area.

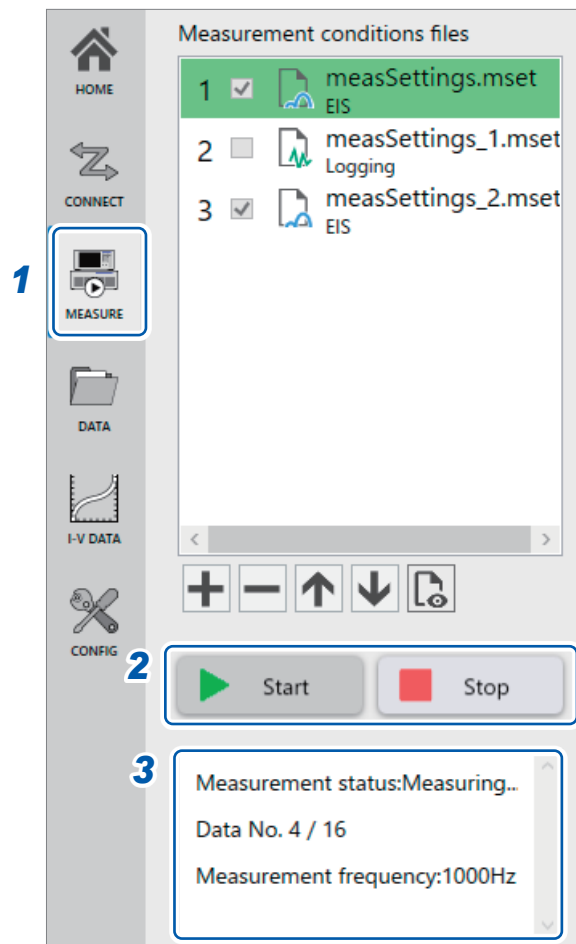

4

4.2 Continuous Measurement (When There Are Multiple Measurement Conditions)

1 Click the Measurement settings ([MEASURE]) tab.

2 Edit the list of the [Measurement conditions files].

If multiple measurement conditions are listed in the [Measurement conditions files], the measurements are conducted in order from top to bottom for the conditions with checked boxes.

For more information about the use of the measurement condition files, see “8.2 Using the Measurement Conditions Files” (p.90).

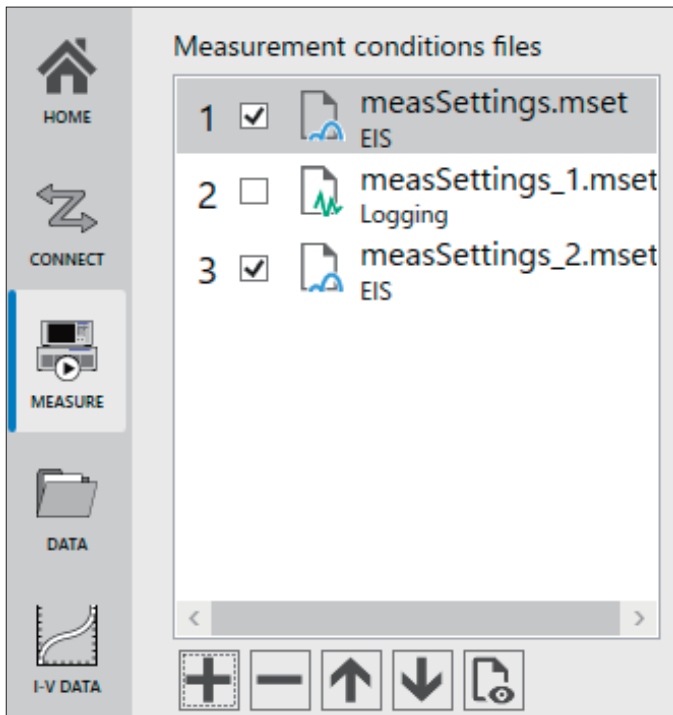

5

Checking Impedance Measurement Results

5.1 Checking the Measurement Data

1 Click the Measurement data ([DATA]) tab.

2 Select the data file you wish to view under [Data files].

There are two categories of data file: [EIS] and [Logging].

Selecting a data file from a different category than the one currently displayed will automatically switch the graph type accordingly. Information for each measured channels will be displayed under [Target information].

3 Select a target from [Target information].

Measurement data for the selected channel will be displayed in the data table at the bottom right of the window, allowing you to check measurement values such as the impedance of each frequency. The next page displays the detailed information for each item in the data table.

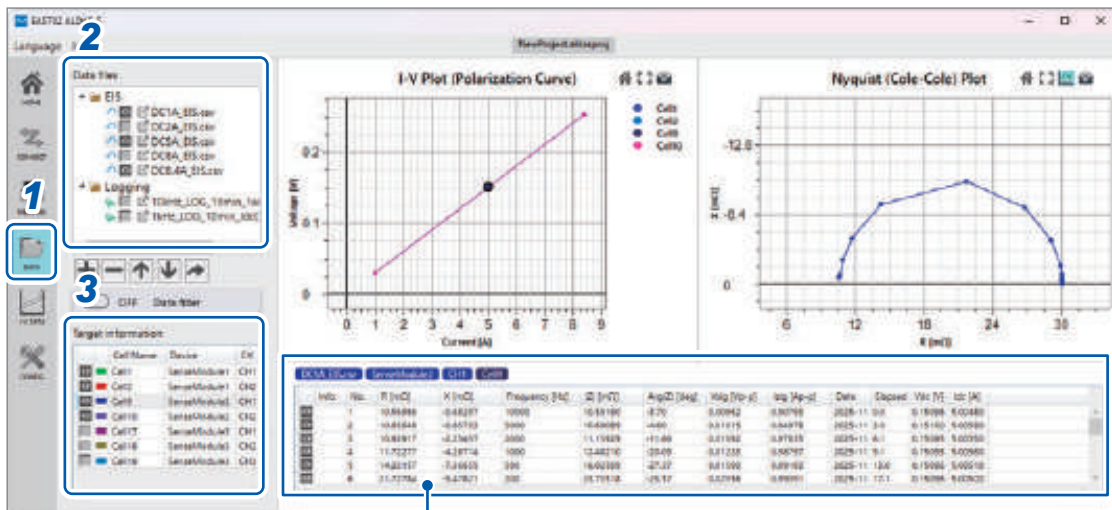

Data table

5

Data table explanation

1	2	3	4	5	6	7	8	9	10
<input checked="" type="checkbox"/>	Info	No.	R [mΩ]	X [mΩ]	Frequency [Hz]	Z [mΩ]	Arg(Z) [deg]	Vsig [Vp-p]	Isig [Ap-p]
<input checked="" type="checkbox"/>		1	468.57277	-193.99339	100000	507.14286	-22.49	0.00201	0.00396
<input type="checkbox"/>		2	88.08412	47.34119	10000	100.00000	28.26	0.00003	0.00028

11	12	13	14
Date	Elapsed	Vdc [V]	Idc [A]
2025-09	0.0	NaN	-0.86670
2025-09	3.5	NaN	-0.86690

No.	Item	Description
1		Selects whether to display the corresponding data in the graph. If the <input checked="" type="checkbox"/> mark is selected, it will be displayed on the graph; if the <input type="checkbox"/> mark is not selected, it will not be displayed on the graph.
2	Info	A warning icon will be displayed if the measured value is abnormal or if there is an error with the measurement conditions. Hover over the icon to see the reason. A warning example are listed below: <ul style="list-style-type: none"> • The measured value contains a non-numeric value (NaN). • The measured values contain infinity values (∞). • A small value of Vsig could lead to a significant measurement error. • Isig is very small compared to the set value. • The real part of the impedance has a negative value.
3	No.	This is the sequence number assigned to each data point as it is collected.
4	R [mΩ]	Real part of the impedance.
5	X [mΩ]	Imaginary part of the impedance.
6	Frequency [Hz]	Frequency at which impedance was measured.
7	Z [mΩ]	Absolute value of the impedance.
8	Arg(Z) [deg]	Phase angle of the impedance.
9	Vsig [Vp-p]	Peak-to-peak of signal's voltage amplitude at the impedance measurement frequency.
10	Isig [Ap-p]	Peak-to-peak of signal's current amplitude at the impedance measurement frequency.
11	Date	The time and date of data acquisition.
12	Elapsed Time [s]	Total time that has passed since the measurement begin.
13	Vdc [V]	Measured DC voltage.
14	Idc [A]	Measured DC current.

Checking the measurement conditions linked to the data file

- 1 Click the button of the measurement condition linked to the data file.

Measurement conditions for each measured data file can be viewed here.

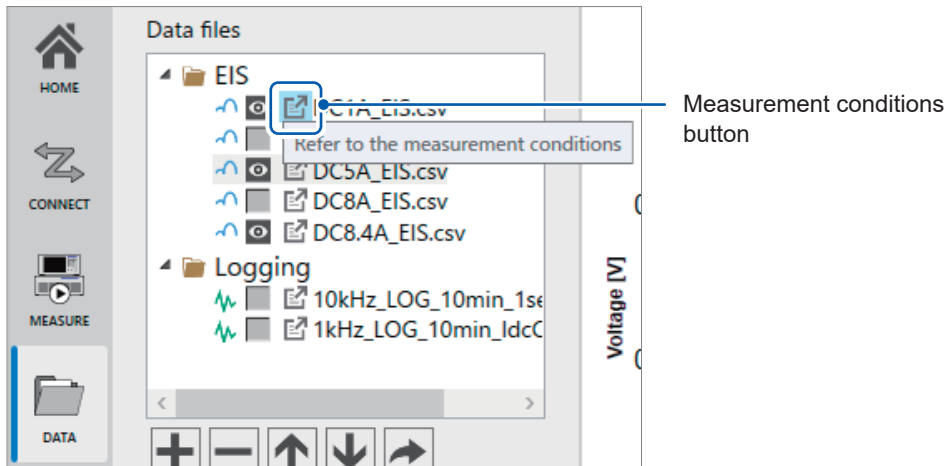

- 2 Click on the tab of the measurement condition item you wish to check.

The contents of the measurement conditions cannot be edited.

Only the **[Note]** in the **[Measurement type settings]** tab can be edited.

This part allows you to enter a memo during measurement and save it together with the measurement data file.

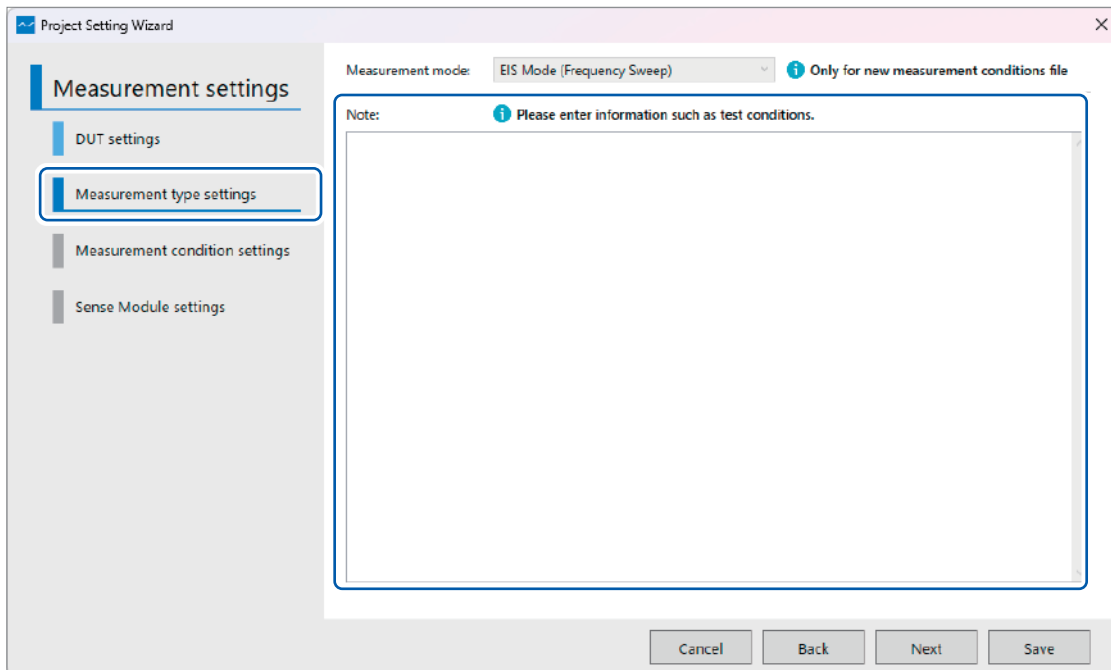

5.2 Configuring the Impedance Graph Settings

1 Click the Configuration settings ([CONFIG]) tab.

Graph's configuration setting will be displayed.

If you selected the [EIS] category data file

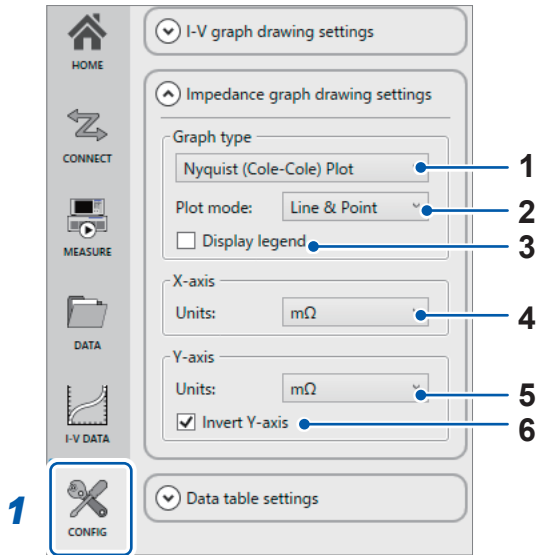

If you selected the [Logging] category data file

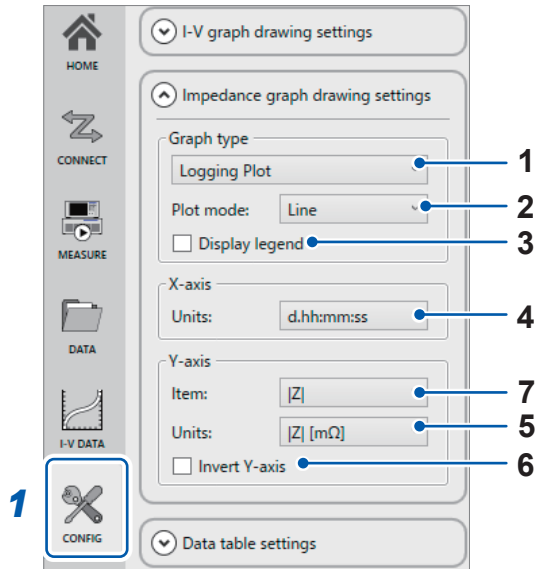

2 Change the impedance graph's configuration settings.

No.	Item	Description
1	Graph type	You can select from the following graph types: For [EIS] category: • Nyquist (Cole-Cole) Plot • Bode Plot For [Logging] category: • Logging Plot
2	Plot mode	You can set the plot mode to Point, Line, or Line & Point.
3	Display legend	The graph legend can be displayed or hidden.
4	X-axis units	You can select the unit prefix for the X-axis to change the scale of the graph.
5	Y-axis units	You can select the unit prefix for the Y-axis to change the scale of the graph.
6	Invert Y-axis	Positive and negative directions for the Y-axis can be inverted for better visualization purposes.
7	Y-axis item	You can change and select the Y-axis item from the drop-down menu depending on the graph types.

5.3 Setting the Data Filter

By using the data filter function, you can search measured data for data that satisfies certain conditions.

1 Click the Measurement data ([DATA]) tab.

2 Click [Data filter].

The data selection window will be displayed.

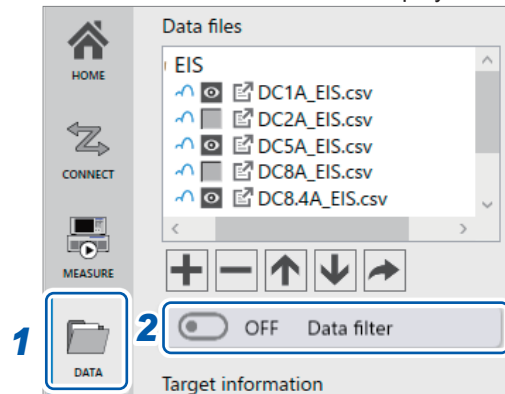

3 Select [Data type].

4 Specify the [Enable highlight mode after filter application] setting.

If the [Enable highlight mode after filter application] checkbox is selected, only measurement targets that match the filter conditions will be highlighted and displayed in the graph.

5 Select detailed search conditions and enter a keyword or value.

Selecting multiple parameters will apply an AND condition.

6 Click [OK].

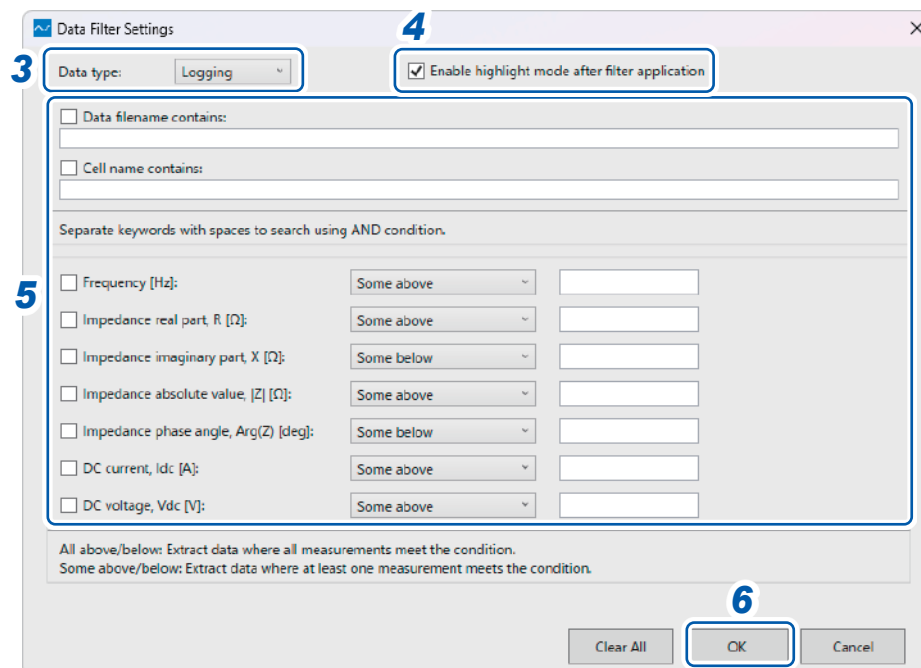

6 I-V Graph

This software generates an I-V graph based on the measured DC current and voltage DC values. The I-V graph is displayed alongside the impedance graph for easy comparison. You can also generate an IR-free graph by entering the cell's ohmic resistance in the cell information.

6.1 Displaying the I-V Graph

1 Click the I-V data ([I-V DATA]) tab.

2 Select the [Display I-V graph] checkbox.

You can display or hide the graph by selecting or deselecting the checkbox.

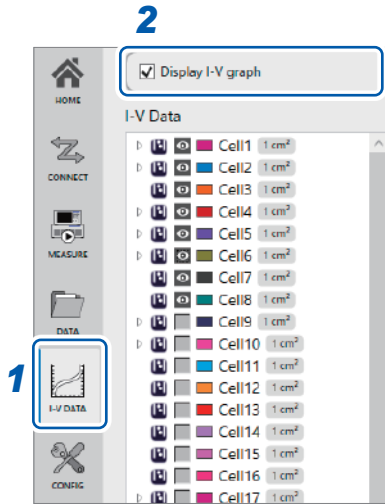

The I-V graph is displayed on the left side of the impedance graph.

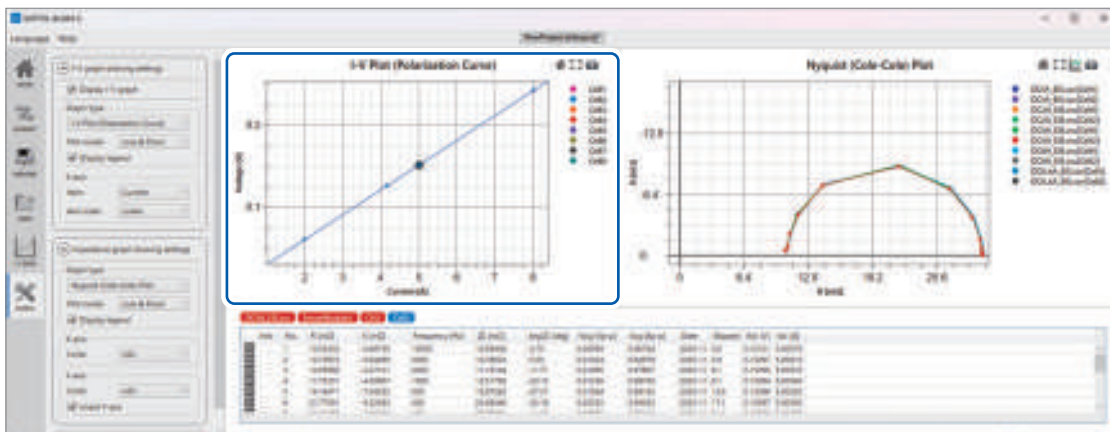

6.2 Configuring the I-V Graph Settings

1 Click the Configuration settings ([CONFIG]) tab.

2 Change [I-V graph drawing settings].

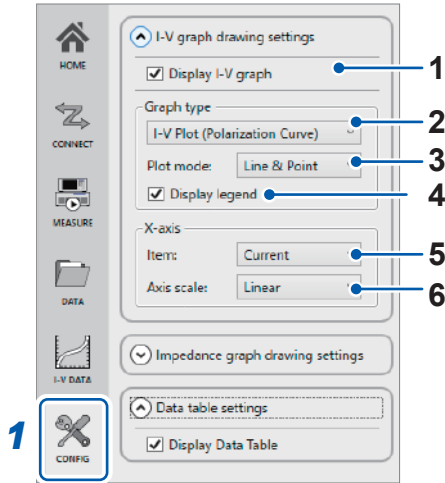

No.	Item	Description
1	Display I-V graph	You can show or hide the I-V graph.
2	Graph type	Graph types available for selection: <ul style="list-style-type: none"> • I-V Plot • IR-free Plot *¹ • I-Power Plot *¹ • I-Impedance Plot *¹
3	Plot mode	Set the plot mode to Point, Line, or Line & Point.
4	Display legend	The graph legend can be displayed or hidden.
5	X-axis Item	The X-axis parameter can be set to either Current or Current Density.
6	X-axis Axis scale	The X-axis scale can be selected as linear or logarithmic.

*1. Graph description:

IR-free Plot

Plots the values calculated using the following formula and the user-specified ohmic resistance value as the **[IR-free Voltage]** value on the vertical axis.

$$\text{IR-free Voltage} = V_{dc} - R_{ohm} \times I_{dc}$$

V_{dc}: DC voltage of the measurement target

I_{dc}: DC current of the measurement target

R_{ohm}: Ohmic resistance specified by the user in cell information

I-Power Plot

Plots the values calculated using the following formula from the measurement data as the **[Power]** value on the vertical axis.

$$\text{Power} = V_{dc} \times I_{dc}$$

V_{dc}: DC voltage of the measurement target

I_{dc}: DC current of the measurement target

I-Impedance Plot

Plots the following measured values as the **[Rh_f]** or **[Rl_f]** value on the vertical axis. You can change these values with the operations in "6.3 Editing I-V Data" (p.81).

R_{hf}: Impedance real part at the highest frequency in the measurement data for the corresponding channel

R_{lf}: Impedance real part at the lowest frequency in the measurement data for the corresponding channel

6.3 Editing I-V Data

Editing cell information

- 1 Click the I-V data ([I-V DATA]) tab.
- 2 Right-click on the cell information you wish to edit in the [I-V Data] list, and then select [Edit cell information].

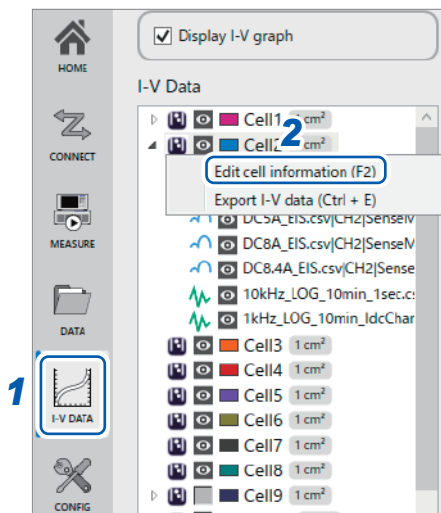

The cell information editing window will be displayed. The cell information set in “Setting the measurement target (DUT)” (p. 60) is displayed in this window.

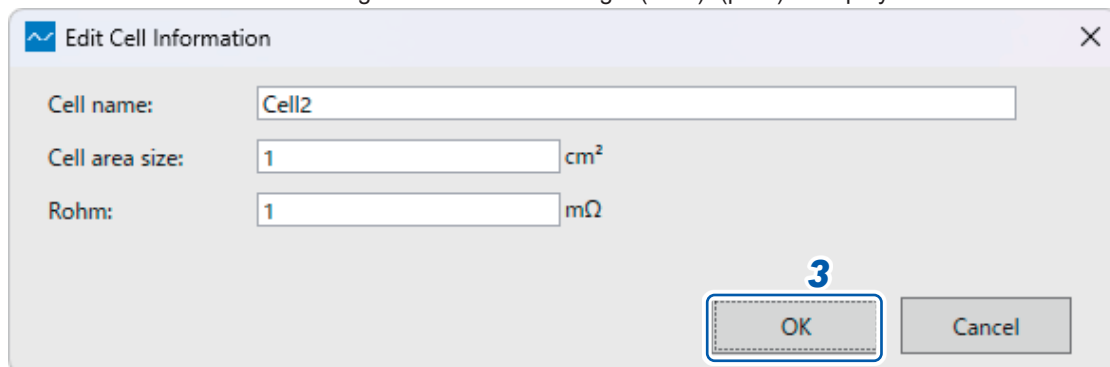

Cell name	You can change the name of the cell displayed on the graph legend and other locations.
Cell area size	By default, the cell size area size is set to “1”, but this value can be modified. This value is used to calculate current density. The default value “1” applies in the following cases: <ul style="list-style-type: none"> • The current density display is not selected • The parameters are unknown • The parameter of the cell area size, etc. is not applicable to the measurement target
Rohm	Specifies the cell’s ohmic resistance. This value is used to calculate IR-free plots. If no value is specified, the default value is 1 mΩ.

- 3 Edit the cell information and click [OK].
The edited information will be applied to the display results.

Editing the I-V information

- 1 Click the I-V data ([I-V DATA]) tab.
- 2 Right-click on the I-V information you wish to edit in the [I-V Data] list, and then select [Edit I-V information].

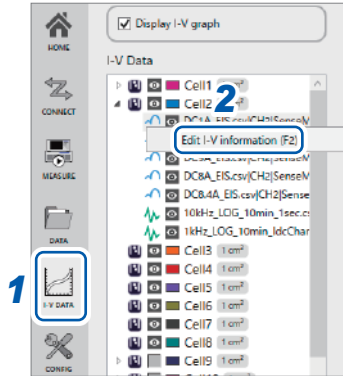

The I-V information editing window will be displayed.

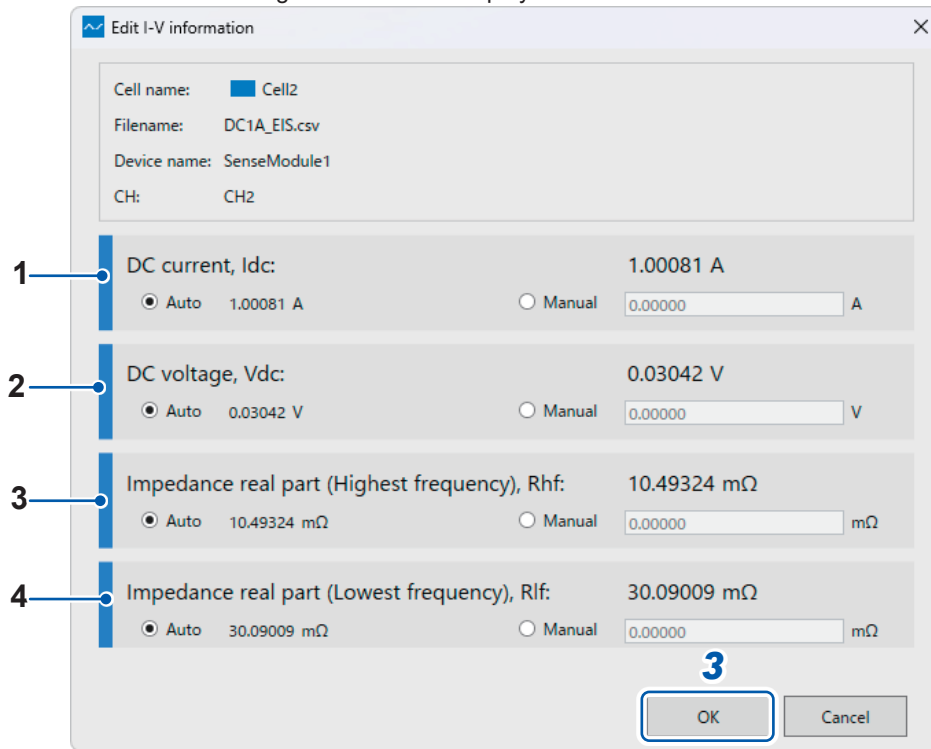

No.	Item	Description
1	DC current, Idc	Measured DC current of the measurement target. When set to [Auto] , the measurement uses the average DC current value in the corresponding impedance measurement data.
2	DC voltage, Vdc	Measured DC voltage of the measurement target. When set to [Auto] , the measurement uses the average DC voltage value in the corresponding impedance measurement data.
3	Impedance real part (Highest frequency), Rhf	This is the real part value of the impedance at the highest frequency, and this value is used to draw the I-Impedance Plot. When set to [Auto] , the measurement uses the real parts of the impedance data at the highest frequency in the respective channel.
4	Impedance real part (Lowest frequency), Rlf	This is the real part value of the impedance at the lowest frequency, and this value is used to draw the I-Impedance Plot. When set to [Auto] , the measurement uses the real parts of the impedance data at the lowest frequency in the respective channel.

3 Edit each item.

- **[Auto]** : automatically use the value calculated from the measurement.
- **[Manual]** : manually enter each value.

4 Click **[OK]**.

The new data values setting will be applied to the results.

I-V information data edited in [Manual]

- Edited data in **[Manual]** will have small yellow pointer.
- I-V data that includes edited data in **[Manual]** will be displayed as a dashed line on the graph.

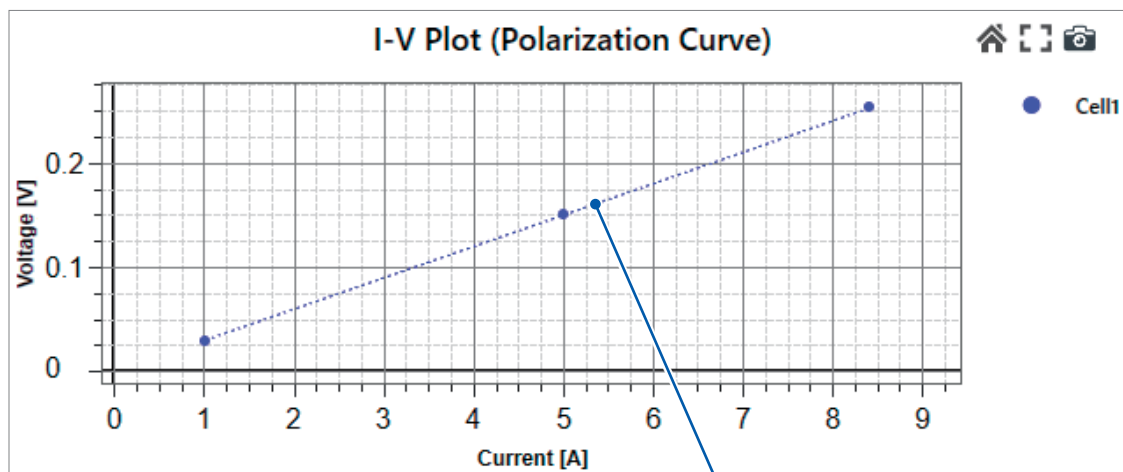
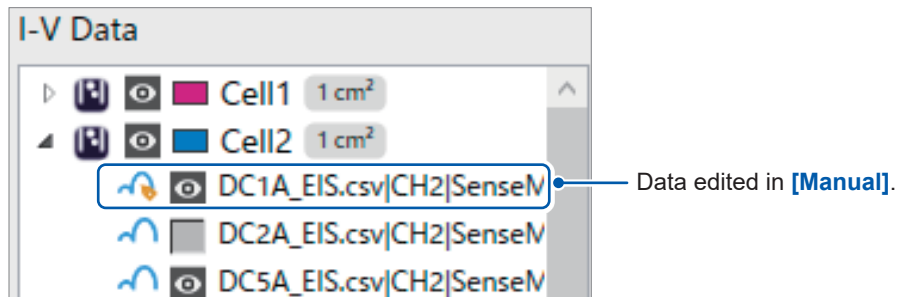

I-V data that includes edited data in **[Manual]**

6.4 Exporting the I-V Data

- 1 Click the I-V data ([I-V DATA]) tab.
- 2 Right-click on the cell information of the [I-V Data] list, and then select [Export I-V data].

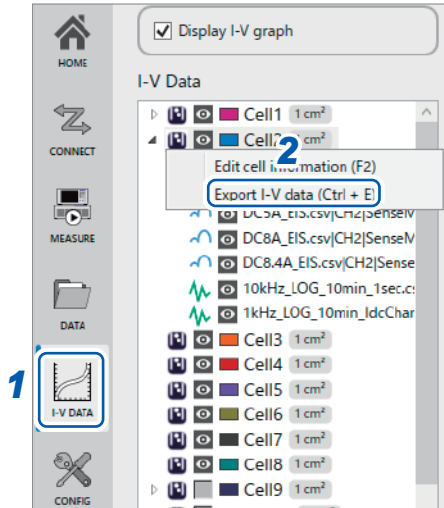

The Export I-V Data Options window will be displayed.

- 3 Specify the saving destination file path and file name for the I-V data, and then click [OK].

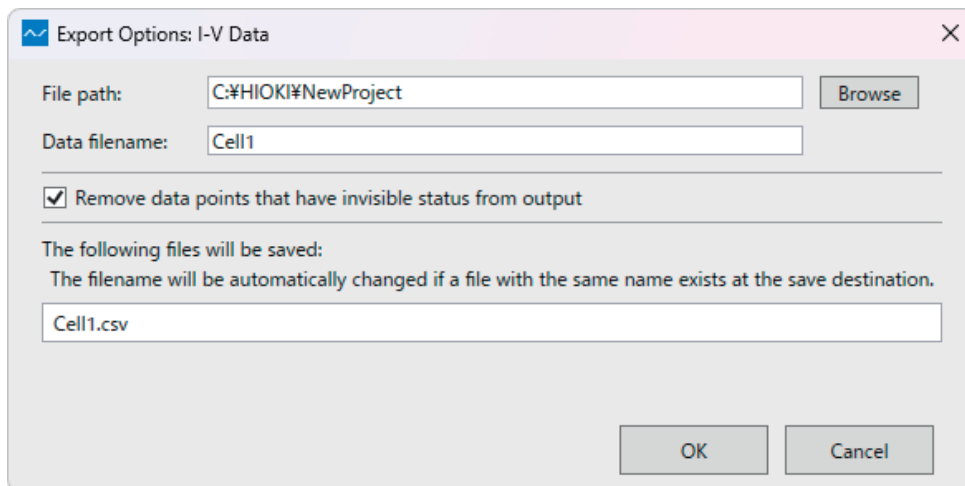

The I-V data will be output to a CSV file.

The format of the I-V data is listed below.

Item	Unit	Description
Idc	A	The DC current value set in [Edit I-V information] window is applied (Auto/Manual).
Vdc	V	The DC voltage value set in [Edit I-V information] window is applied (Auto/Manual).
Current Density	A/cm ²	The current density is calculated by dividing the DC current value by the cross-sectional area of the cell.
Rhf	Ω	The impedance real part value corresponding to the highest frequency in the data set from the [Edit I-V information] window.
Rlf	Ω	The impedance real part value corresponding to the lowest frequency in the data set from the [Edit I-V information] window.

7

Graph Common Operation

7.1 Setting for Displaying or Hiding the Measurement Data Graph



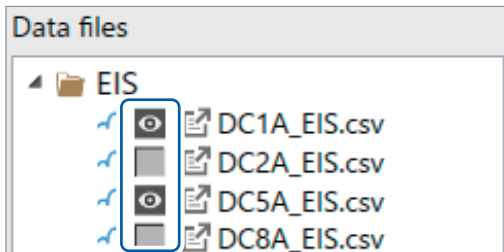

You can select or deselect the  mark to show or hide data on the graph.

For data files



Changes the display for all data in the selected file.





For target information

	Cell Name	Device	CH
	Cell1	SenseModule1	CH1
	Cell2	SenseModule1	CH2
	Cell4	SenseModule1	CH4
	Cell5	SenseModule1	CH5

Changes the display for data from the selected channel.

For the data table

DC1A_EIS.csv SenseModule1 CH1 Cell1

	Info	No.	R [mΩ]	X [mΩ]	Frequency [Hz]
		1	10.52955	-0.45660	10000
		2	10.63287	-0.89698	5000
		3	10.99809	-2.39475	2000
		4	11.81300	-4.47578	1000

Changes the display for each selected data point.

7.2 Viewing Graphs

Viewing Graphs Using the Buttons

You can control the graph view with the buttons located at the top-right of the graph.

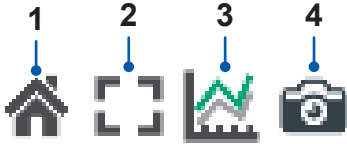

No.	Button label	Description
1	Reset Axes	Resets the graph to its default view, automatically scaling it to fit the entire graph with zeros on both axes.
2	Auto Scale	Resets the graph to its default view, automatically scaling it to fit the entire graph.
3	Plot Highlight	Impedance graph only The graph line of the selected data will be shown in its original color, while other lines will be grayed out. This feature makes it easier to focus on a specific set of data when multiple data sets are displayed on the graph.
4	Snap Shot	Captures the graph display and saves it as an image.

Viewing graphs using the mouse

You can use these mouse action to explore and analyze the graph data more effectively.

Mouse operation	Description
Left-click and drag	Enlarges selected area.
Right-click and drag	Grab and move the graph.
Double left-click	Resets the graph to its default view, automatically scaling it to fit the entire graph.
Double right-click	If a point was selected, this action will cancel the data point selection on the graph.
Scroll wheel	Zoom in and out.

7.3 Displaying the Data Details on Graphs

- 1** Hover the mouse cursor to a point on the graph.
The measurement information at that data point will appear.

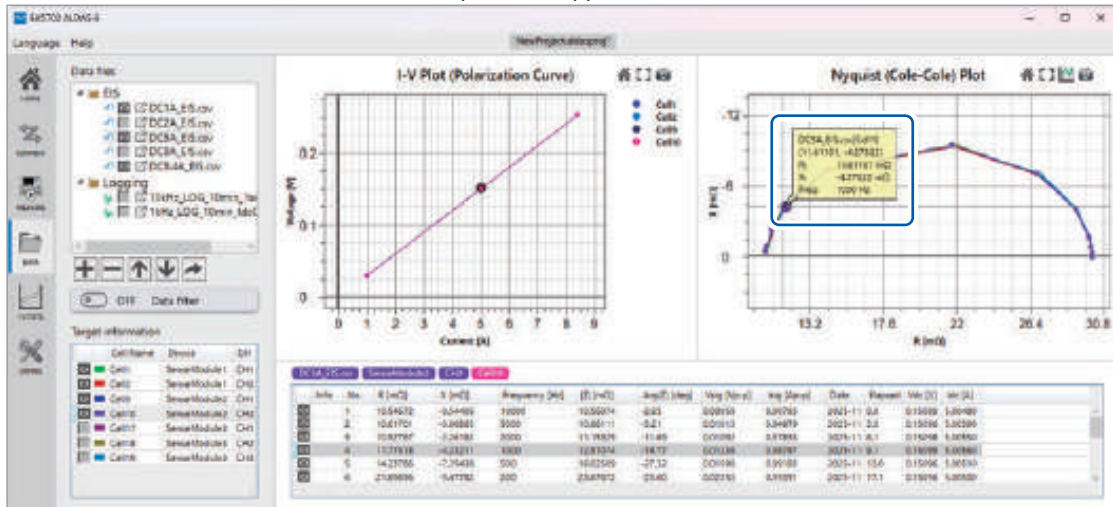

- 2** Click a point on the graph.
The selected point will be highlighted.
The data file, target information, and data table corresponding to the selected plot are displayed in each screen element. Additionally, the corresponding data is selected in the data table.

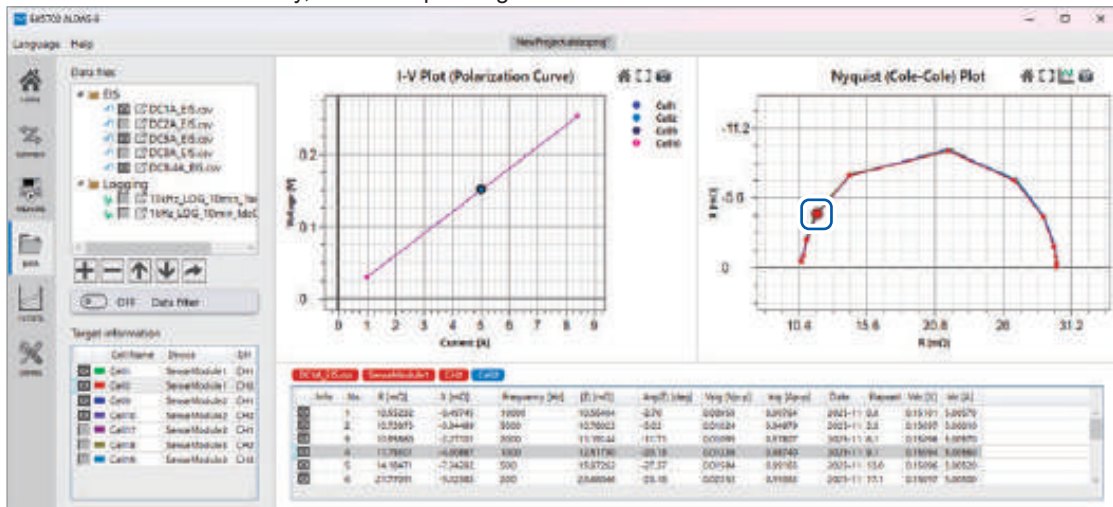

7.4 Setting the Graph Color and Marker Shape

- 1 Click the colored square button.

Target information			
	Cell Name	Device	CH
	Cell1	SenseModule1	CH1
	Cell2	SenseModule1	CH2
	Cell4	SenseModule1	CH4
	Cell5	SenseModule1	CH5

A **[Plot Options]** setting window will be displayed for the selected target information.

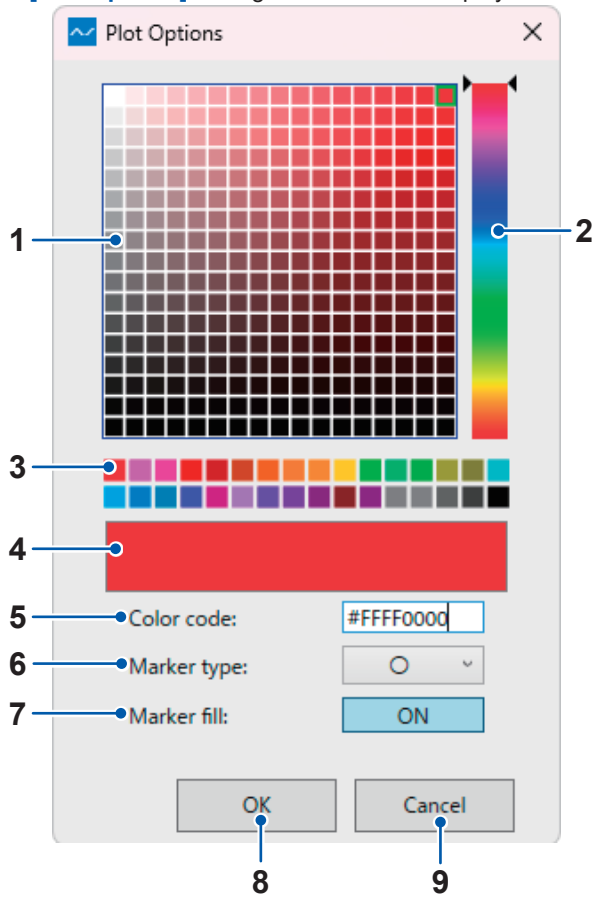

No.	Description
1	Select the graph color from a grid display.
2	Select a hue from a color bar.
3	Select the graph color from a number of color presets.
4	Displays the selected color.
5	Displays the color code for the selected color. You can also edit the color code directly.
6	Select the marker shape.
7	Enable or disable marker fill.
8	Click [OK] to apply the changes to the graph.
9	Discards changes and closes the window.

8

Manipulating Files

8.1 Checking the System Connection Status and Reconnection

The measurement condition cannot be set if the application fails to verify the connection to the system devices after starting the project. Please verify the connection using the following steps:

- 1 Open the Connection settings ([CONNECT]) tab and click the [Connection status] button.



- 2 To reconnect, click either the [Connected] or [Not connected] button.

A window for [Instrument settings] will be displayed.

Click either the [Connected] or [Not connected] button to reconnect with the system.

See "3.4 Setting the System Configuration (Communication Connection with the System)" (p.58).

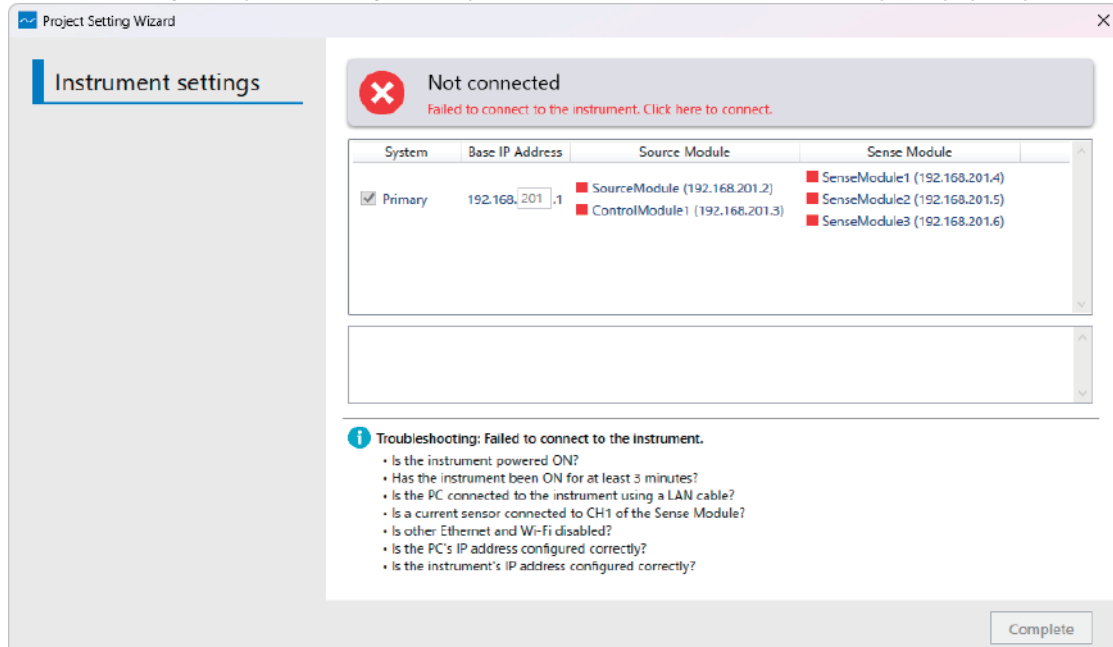

8.2 Using the Measurement Conditions Files

Adding, deleting, and sorting the measurement conditions

- 1 Click the Measurement settings ([MEASURE]) tab.
- 2 Use the files using the buttons at the bottom of the [Measurement conditions files] list.

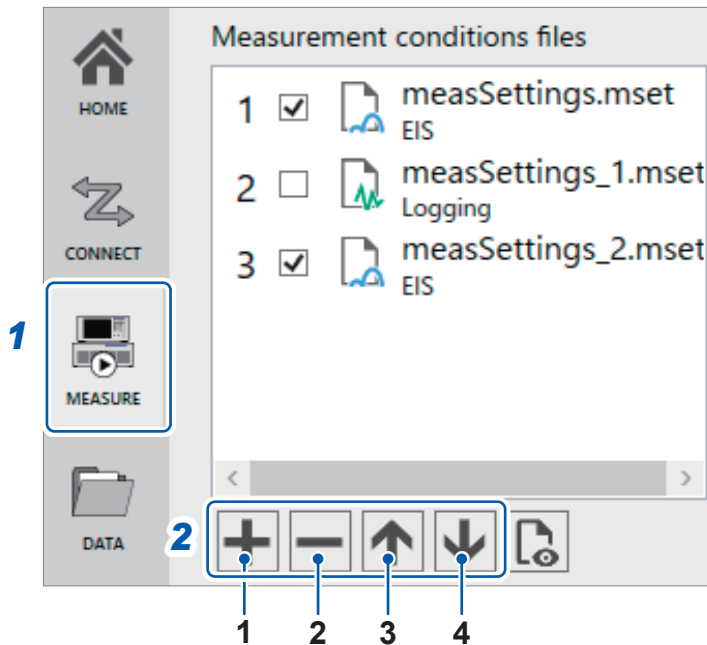

No.	Button label	Description
1	Add	Adds a new measurement condition.
2	Delete	Deletes the selected file.
3	Up	Moves the selected file up.
4	Down	Moves the selected file down.

Changing the existing measurement conditions

- 1 Click the Measurement settings ([MEASURE]) tab.
- 2 Double-click the measurement conditions file you wish to edit on the [Measurement conditions files] list.

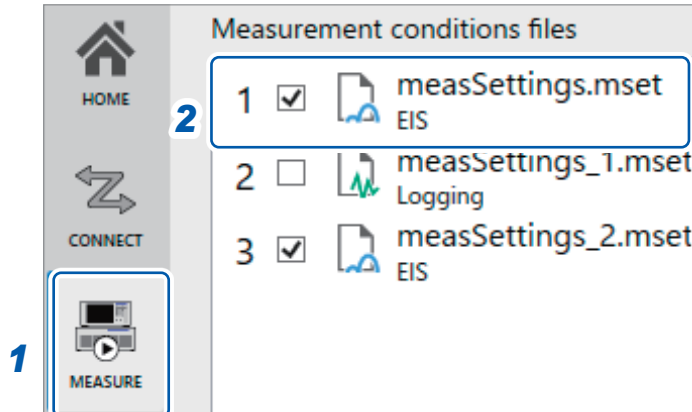

The measurement conditions setting window will be displayed.

- 3 Edit the parameter you wish to change and Click [Complete].

For more information about how to set the measurement conditions, see "3.5 Setting the Measurement Method" (p.60).

You can navigate the [Measurement settings] by selecting the tab available on the left-hand side of the [Project Settings] window.

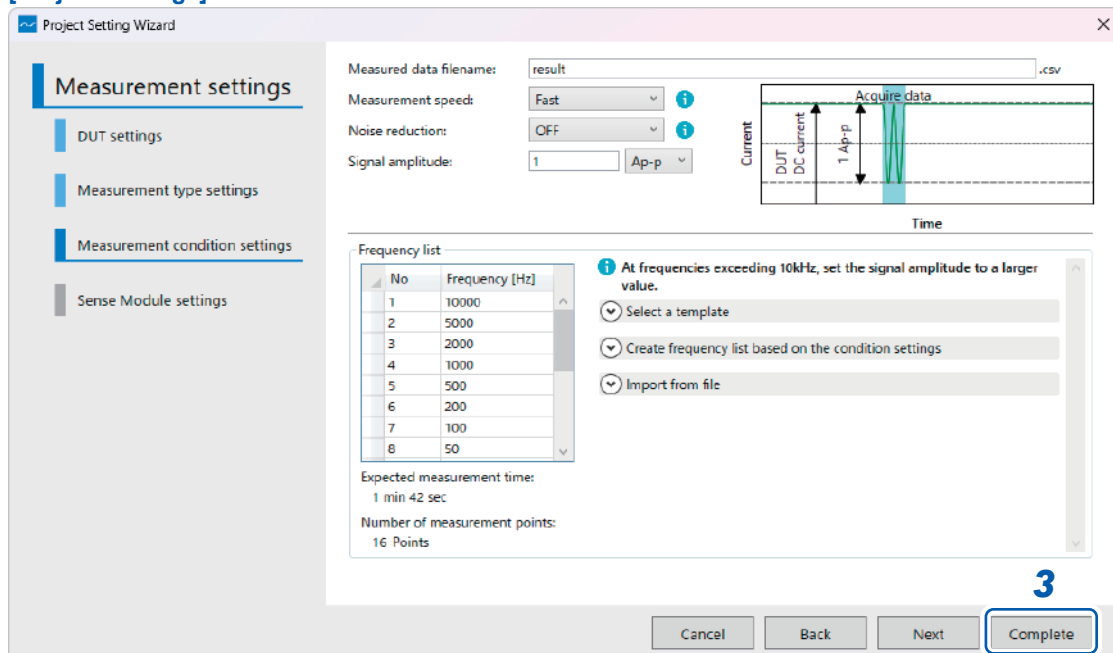

A dialog box confirming whether you wish to overwrite the settings will be displayed.

- 4 Click [Yes].

This will overwrite the measurement conditions with the new settings and save them.

Adding the existing measurement conditions

If you wish to copy and use measurement conditions created in another project, you can load them to this project [\[Measurement condition files\]](#) list.

Measurement conditions files are saved in the [\[MeasurementSettings\]](#) folder with “.mset” extension in the project folder.

- 1 Click the Measurement settings (**[MEASURE]**) tab.
- 2 Drag and drop the measurement conditions file you wish to load onto the [\[Measurement conditions files\]](#).

The measurement conditions will be loaded to the [\[Measurement conditions files\]](#) list.

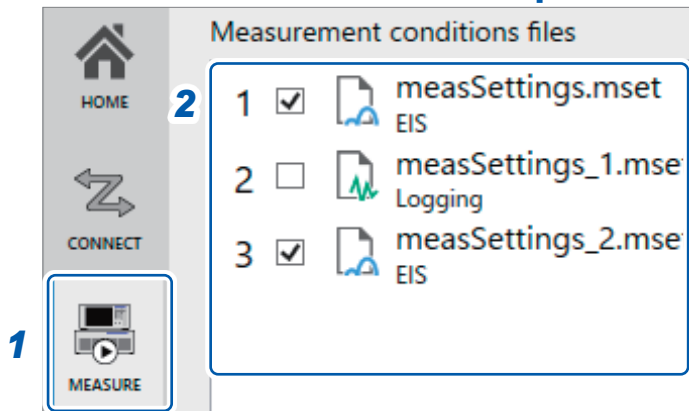

Changing the measurement condition file names

You can change the filename used to store measurement conditions.

- 1 Click the Measurement settings ([MEASURE]) tab.
- 2 Right-click the file for which you wish to change the name of the [Measurement conditions files] list.

The command menu will be displayed.

Alternatively, pressing the F2 key while a measurement conditions file is selected will display a screen allowing you to change the measurement conditions filename.

- 3 Click [Rename the measurement conditions file].

A screen allowing you to change the measurement conditions filename will be displayed.

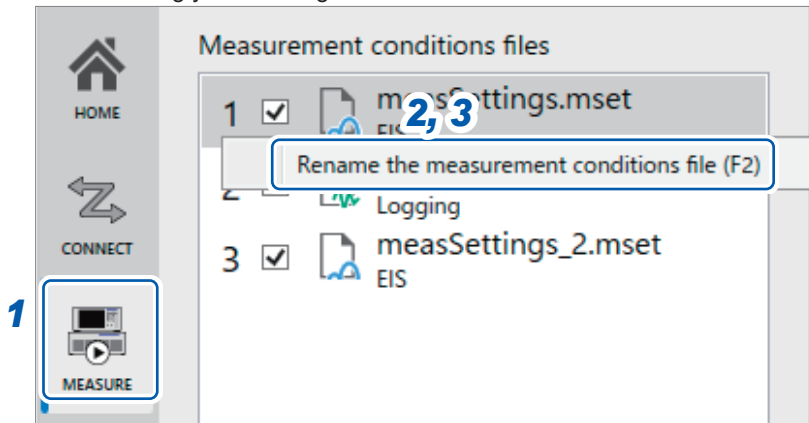

Adding data using the data file **[+]** button

You can add data using the menu shown when you click the **[+]** button underneath the **[Data files]** list.

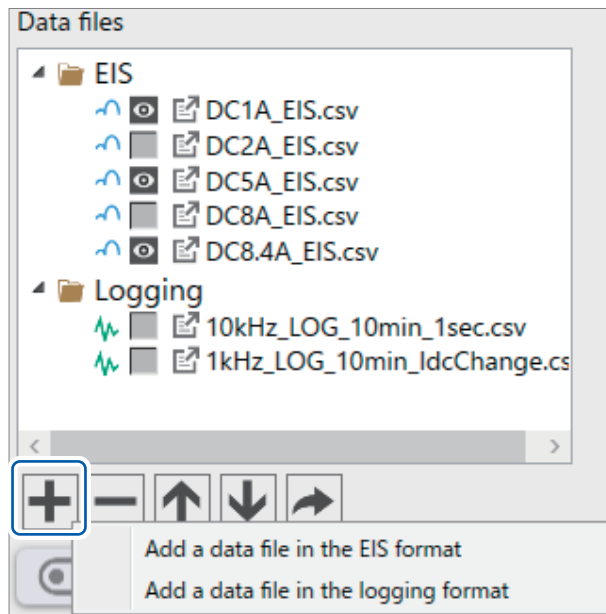

Loading data measured in a different project (including measurement conditions)

Folders named **[Data filename_Archive]** are generated in the **[DataFiles]** folder in the project folder.

You can drag and drop **[.darchive]** files inside any folder onto the **[Data files]** list or graph of the currently open project.

This allows you to load the data contained in the file, including links to measurement conditions from the time of measurement.

Changing the data file names

The names of data files can be changed.

- 1** Right-click the file you want to rename in the [Data files] list.

The command menu will be displayed.

- 2** Click [Rename the data file].

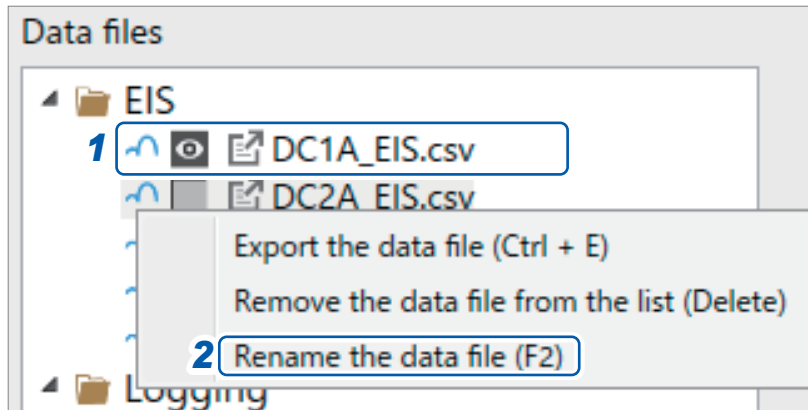

This command allows you to change the data file's name.

- 3** Enter a new filename and click [OK].

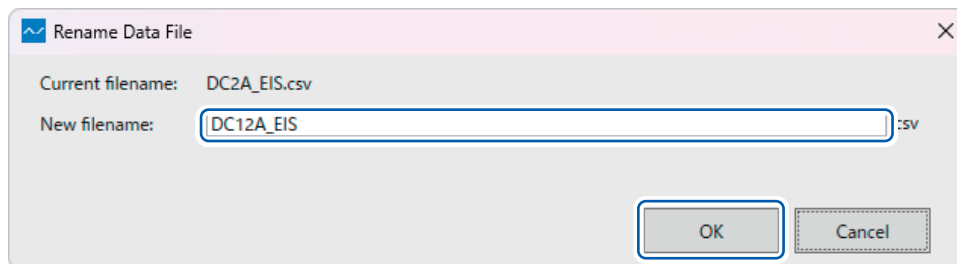

Deleting data files from the list

The data file will be removed from the measurement project but will remain in the project folder's **[DataFiles]** folder.

Deleting a file on the list

You can delete data files from the list.

1 Right-click the data file you wish to delete.

The command menu will be displayed.

2 Click **[Remove the data file from the list]**.

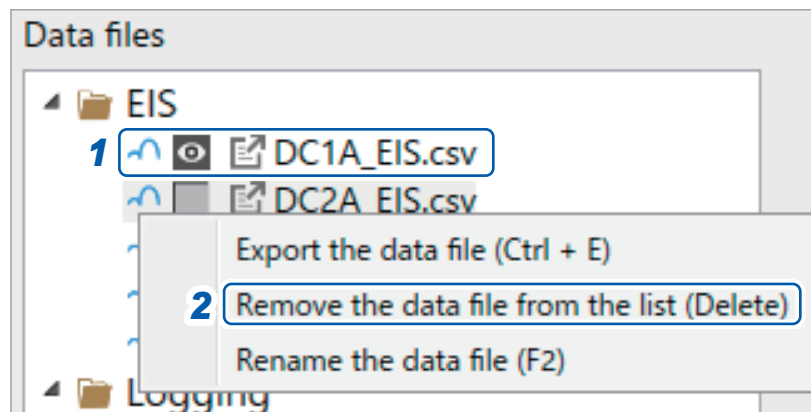

A confirmation dialog box will be displayed.

3 Click **[Yes]**.

The data file will be removed from the list.

Deleting a file using the menu

You can delete a data file using the command menu.

- 1** Select the data file you wish to delete.
- 2** Click the [-] button underneath the [Data files].
The command menu will be displayed.
- 3** Click [Remove the selected data file from the list].

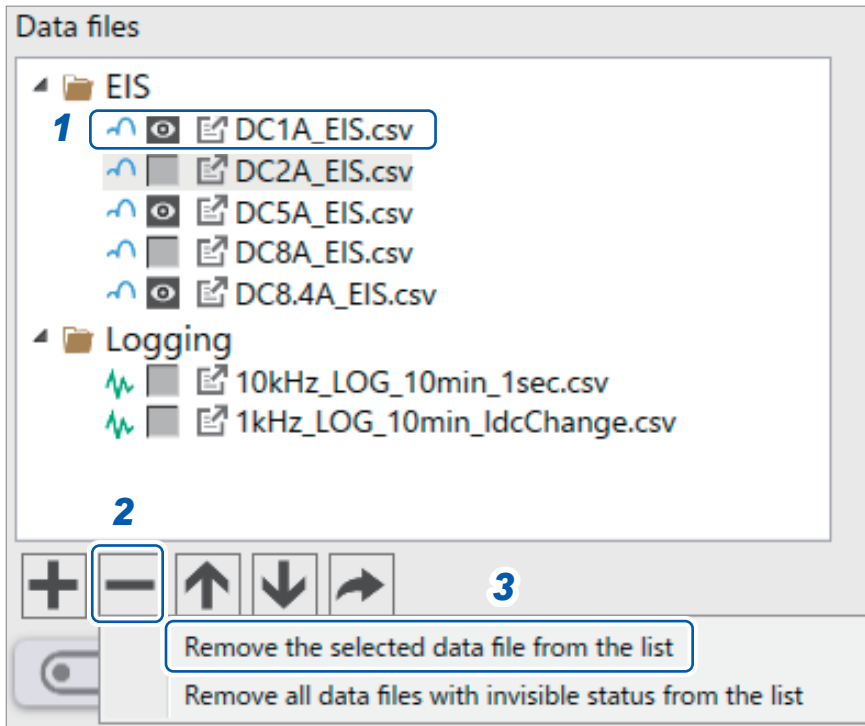

A confirmation dialog box will be displayed.

- 4** Click [Yes].
The data file will be removed from the list.

Exporting data files

- 1 Right-click the data file you wish to export in a different file format.
The command menu will be displayed.

- 2 Click **[Export the data file]**.

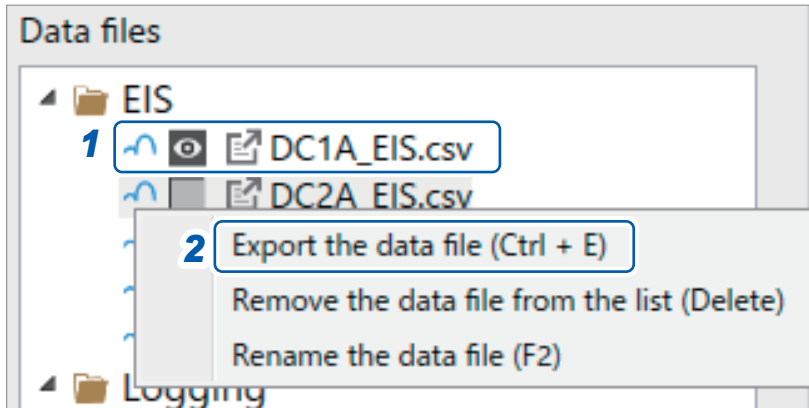

The data file export window will be displayed.

- 3 Set each export option item and click **[OK]**.

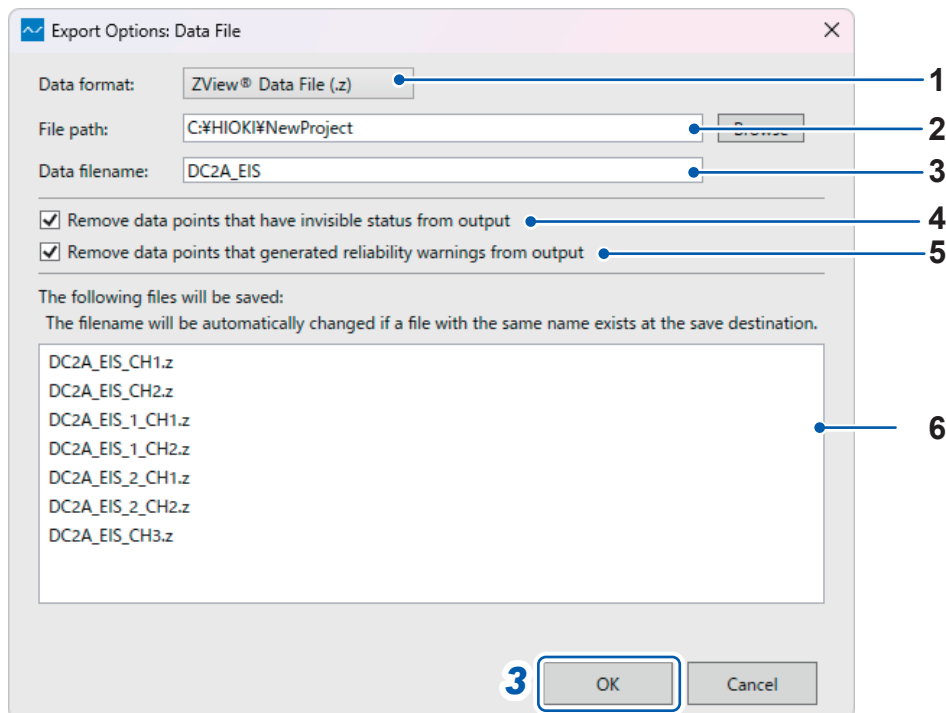

No.	Item	Description
1	Data format	Select the data file export format: • Z VIEW format: [ZView File(.Z)] • Multi-plot format: [Multi-plot File(.csv)]
2	File path	Specifies the folder where the file will be saved.
3	Data filename	Specifies the new data file name.
4	Remove data points that have invisible status from output	Removes data from the output file for which the  mark is not selected in Data table.
5	Remove data points that generated reliability warnings from output	Removes the data with the warning icon in [Info] from the output file.
6	The following files will be saved	Displays a list of data file names that will be saved.

The ALDAS data format

[ChannelNo.] will be replaced by the channel number.

Example: For CH2, "R_SenseModule1_Ch2", etc.

EIS format

Item	Unit	Description
Date		The time and date of data acquisition.
ElapsedTime	s	Total time that has passed since the measurement begin.
SetFrequency	Hz	Frequency set in the measurement conditions.
MeasuredFrequency_SenseModule1_Ch[ChannelNo.]	Hz	Indicates the frequency at which the impedance was measured.
R_SenseModule1_Ch[ChannelNo.]	Ω	Real part of the impedance.
X_SenseModule1_Ch[ChannelNo.]	Ω	Imaginary part of the impedance.
AbsZ_SenseModule1_Ch[ChannelNo.]	Ω	Absolute value of the impedance.
ArgZ_SenseModule1_Ch[ChannelNo.]	$^{\circ}$	Phase angle of the impedance.
Vsig_SenseModule1_Ch[ChannelNo.]	Vp-p	Peak-to-peak of signal's voltage amplitude at the impedance measurement frequency.
Isig_SenseModule1_Ch[ChannelNo.]	Ap-p	Peak-to-peak of signal's current amplitude at the impedance measurement frequency.
Vdc_SenseModule1_Ch[ChannelNo.]	V	DC voltage value.
Idc_SenseModule1_Ch[ChannelNo.]	A	DC current value.

Logging format

Item	Unit	Description
ElapsedTime		Total time that has passed since the measurement begin.
Date	s	The time and date of data acquisition.
SetFrequency	Hz	Frequency set in the measurement conditions.
MeasuredFrequency_SenseModule1_Ch[ChannelNo.]	Hz	Indicates the frequency at which the impedance was measured.
R_SenseModule1_Ch[ChannelNo.]	Ω	Real part of the impedance.
X_SenseModule1_Ch[ChannelNo.]	Ω	Imaginary part of the impedance.
AbsZ_SenseModule1_Ch[ChannelNo.]	Ω	Absolute value of the impedance.
ArgZ_SenseModule1_Ch[ChannelNo.]	$^{\circ}$	Phase angle of the impedance.
Vsig_SenseModule1_Ch[ChannelNo.]	Vp-p	Peak-to-peak of signal's voltage amplitude at the impedance measurement frequency.
Isig_SenseModule1_Ch[ChannelNo.]	Ap-p	Peak-to-peak of signal's current amplitude at the impedance measurement frequency.
Vdc_SenseModule1_Ch[ChannelNo.]	V	DC voltage value.
Idc_SenseModule1_Ch[ChannelNo.]	A	DC current value.

8.4 Manipulating Project Files

1 Use the project files in the [HOME] tab window.

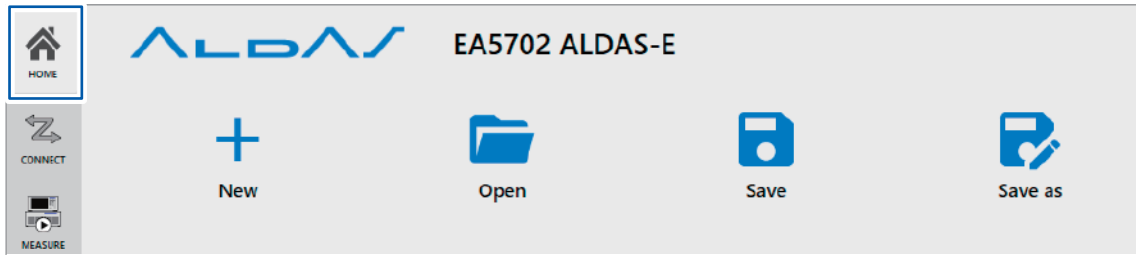

Button label	Description
New	Creates a new project. Perform settings according to "3 Configuring the PC Application" (p.55).
Open	Opens an existing project. Go to the directory of the project you wish to open in the file selection window, and then select the [Project name.aldasproj] file.
Save	Saves the status of the current project. Alternatively, use [ctrl]+[s] keys while the application is active will save the current project's state. The following information is saved when a project is saved: <ul style="list-style-type: none"> • Hardware component information • Measurement conditions file list • Data file list • Data files and Measurement condition file links • Data display/hide attributes • Graph color and marker shape information • Data reliability information
Save as	You can change a project's name as well as the directory in which it is stored. A folder with the same name as the project will be created in the specified directory, and the project file and related data files will be copied into it.

9

Ending Measurement

9.1 Exiting the PC Application

1 Confirm that the measurement operation has ended.

If any changes were made to the project, please save the project before exiting. (The current project file will be overwritten.)

2 Click the close button on the window.

The PC application will close.

9.2 Turning Off the System Power

CAUTION



- Ensure the measurement target's DC power supply is turned off and the system detects no voltage or current before shutting down the system.

Failure to follow this guidance could damage the device.

1 Turn off the measurement target's DC power supply.

2 Verify that there is no voltage or current detected from the measurement target by the Sense Module.

3 Turn off (O) the start/stop switch on the front panel of the EA5901 Control Module.

The power to the Control Module and all the devices connected to the power outlets of the Control Module will turn off.

4 Turn off (O) the main breaker on the back of EA5901 Control Module.

The power to the Control Module will turn off completely.

9.3 Disconnecting the Cables and Current Sensor from the Measurement Target

DANGER



- Turn off the power supply to the measurement target and measurement lines before disconnecting the Sense Cables, Source Cables, and current sensor.

Failure to do so could result in electric shock.

1 Disconnect the Sense Cable, current sensor, and Source Cable from the measurement target.

10 Sensor Branch Module

10.1 Overview of the Sensor Branch Module

The Z5405 Sensor Branch Module is capable of branching the waveform output from the optional current measurement product connected to the INPUT terminal up to three outputs. Use this module when connecting two or more EA5302 Sense Modules.

10.2 Part Names and Functions

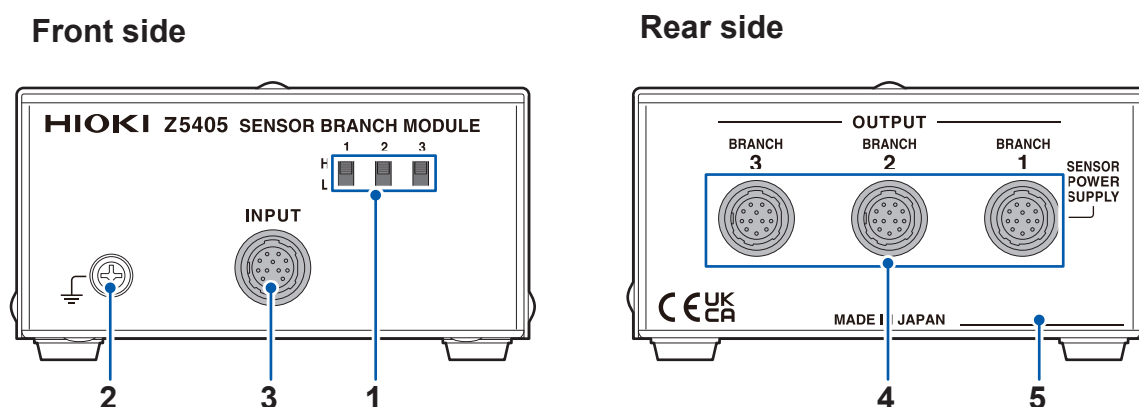

1	Current sensor rating setting switch	Set either H or L for each switch according to the rated current of the current sensor to be connected.	p. 106
2	Functional grounding terminal	In some situations, it is possible to reduce noise by grounding this terminal or by connecting it to the grounding terminal of the destination device. Use it as needed.	—
3	INPUT terminal Hioki's ME15W (female)	Connect the current sensor or CT9557 Sensor Unit to this terminal.	p. 106
4	OUTPUT terminal Hioki's ME15W (male)	Connect the EA5302 Sense Module to this terminal using the CT9904 Connection Cable. Ensure that BRANCH 1 is used for the power supply to the current sensor.	p. 106
5	Serial number	For the latest information, check Hioki's website.	—

10.3 Current Sensor Rating Setting (Switch)

Set either H or L for the current sensor rating setting switch according to the rated current of the current sensor to be connected to the Sensor Branch Module. When the CT9557 Sensor Unit is connected, perform settings according to the rated current of the current sensor connected to the CT9557.

Current sensor rating setting table

Current sensor rated current	Switch No.		
	1	2	3
5000 A	L	L	H
2000 A	L	L	L
1000 A 500 A 50 A	H	L	H
200 A	H	L	L
20 A	H	H	L
—	L	H	L
—	L	H	H
—	H	H	H

10.4 Sensor Branch Module Connection Method

Use the CT9904 Connection Cable to connect the Sensor Branch Module to each Sense Module and CT9557 Sensor Unit.

IMPORTANT

- Always connect the CT9904 Connection Cable to CH1 (Probe 1 terminal) of the Sense Module.
- Be sure to use BRANCH 1 to supply power to the current sensor.

Connection example

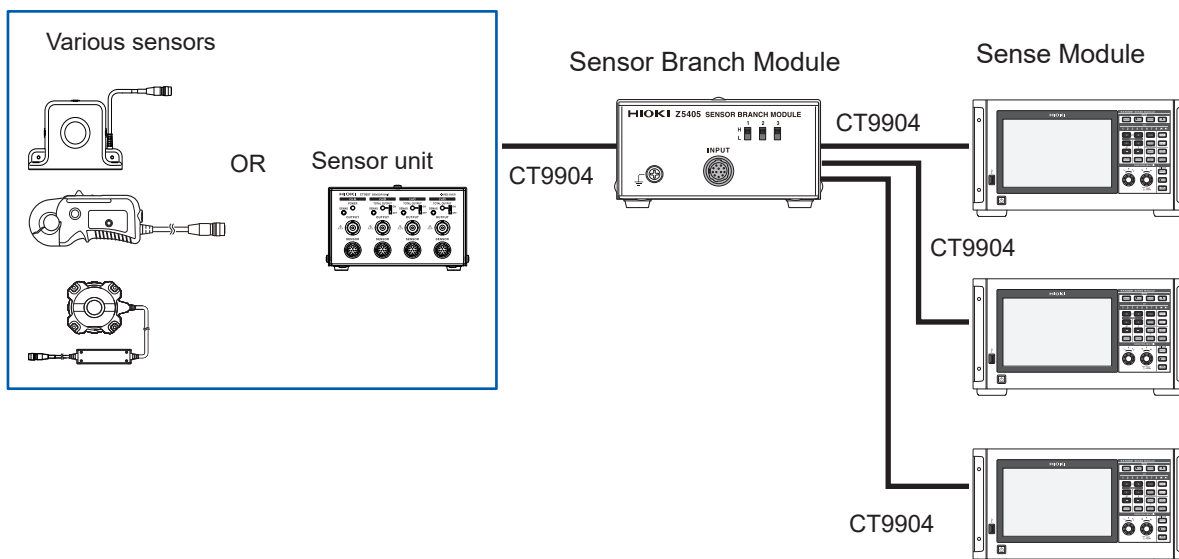

11.1 EA5702 ALDAS-E

General specifications

(1) System architecture

ALDAS-E	EA5702 ALDAS-E (PC application)												
	EA5302 Sense Module												
	• Constituent units: 1 or 3 modules (primary)												
	<table border="1"> <thead> <tr> <th>Display name</th> <th>IP address</th> <th>Subnet mask</th> </tr> </thead> <tbody> <tr> <td>Sense Module 1</td> <td>192.168.201.4</td> <td>255.255.0.0</td> </tr> <tr> <td>Sense Module 2</td> <td>192.168.201.5</td> <td>255.255.0.0</td> </tr> <tr> <td>Sense Module 3</td> <td>192.168.201.6</td> <td>255.255.0.0</td> </tr> </tbody> </table>	Display name	IP address	Subnet mask	Sense Module 1	192.168.201.4	255.255.0.0	Sense Module 2	192.168.201.5	255.255.0.0	Sense Module 3	192.168.201.6	255.255.0.0
Display name	IP address	Subnet mask											
Sense Module 1	192.168.201.4	255.255.0.0											
Sense Module 2	192.168.201.5	255.255.0.0											
Sense Module 3	192.168.201.6	255.255.0.0											
	• Constituent units: 1 to 3 modules (secondary)												
	<table border="1"> <thead> <tr> <th>Display name</th> <th>IP address</th> <th>Subnet mask</th> </tr> </thead> <tbody> <tr> <td>Sense Module 4</td> <td>192.168.202.4</td> <td>255.255.0.0</td> </tr> <tr> <td>Sense Module 5</td> <td>192.168.202.5</td> <td>255.255.0.0</td> </tr> <tr> <td>Sense Module 6</td> <td>192.168.202.6</td> <td>255.255.0.0</td> </tr> </tbody> </table>	Display name	IP address	Subnet mask	Sense Module 4	192.168.202.4	255.255.0.0	Sense Module 5	192.168.202.5	255.255.0.0	Sense Module 6	192.168.202.6	255.255.0.0
Display name	IP address	Subnet mask											
Sense Module 4	192.168.202.4	255.255.0.0											
Sense Module 5	192.168.202.5	255.255.0.0											
Sense Module 6	192.168.202.6	255.255.0.0											
	EA5502 Source Module												
	• Constituent units: 1 or 2 modules (primary)												
	<table border="1"> <thead> <tr> <th>Display name</th> <th>IP address</th> <th>Subnet mask</th> </tr> </thead> <tbody> <tr> <td>Source Module</td> <td>192.168.201.2</td> <td>255.255.0.0</td> </tr> </tbody> </table>	Display name	IP address	Subnet mask	Source Module	192.168.201.2	255.255.0.0						
Display name	IP address	Subnet mask											
Source Module	192.168.201.2	255.255.0.0											
	EA5901 Control Module												
	• Constituent units: 1 module (primary)												
	<table border="1"> <thead> <tr> <th>Display name</th> <th>IP address</th> <th>Subnet mask</th> </tr> </thead> <tbody> <tr> <td>Base IP Address</td> <td>192.168.201.1</td> <td>255.255.0.0</td> </tr> <tr> <td>Control Module1</td> <td>192.168.201.3</td> <td>255.255.0.0</td> </tr> </tbody> </table>	Display name	IP address	Subnet mask	Base IP Address	192.168.201.1	255.255.0.0	Control Module1	192.168.201.3	255.255.0.0			
Display name	IP address	Subnet mask											
Base IP Address	192.168.201.1	255.255.0.0											
Control Module1	192.168.201.3	255.255.0.0											
	• Constituent units: 1 module (secondary)												
	<table border="1"> <thead> <tr> <th>Display name</th> <th>IP address</th> <th>Subnet mask</th> </tr> </thead> <tbody> <tr> <td>Base IP Address</td> <td>192.168.202.1</td> <td>255.255.0.0</td> </tr> <tr> <td>Control Module 2</td> <td>192.168.202.3</td> <td>255.255.0.0</td> </tr> </tbody> </table>	Display name	IP address	Subnet mask	Base IP Address	192.168.202.1	255.255.0.0	Control Module 2	192.168.202.3	255.255.0.0			
Display name	IP address	Subnet mask											
Base IP Address	192.168.202.1	255.255.0.0											
Control Module 2	192.168.202.3	255.255.0.0											

(2) PC application operating environment

Operating system	Windows11 Home/Pro/Enterprise/Enterprise LTSC
.NET library	Microsoft .NET Framework Runtime 4.8.1 or later
Processor	Intel® Core 5 or higher Clock speed of 2 GHz or higher and at least 2 physical cores
RAM	Minimum requirements: When the total number of channels is 8 or less: 8 GB or more When the total number of channels exceeds 8: 16 GB or more
Storage	Available space: At least 2 GB

Display	Resolution of at least 1920 × 1080 pixels
Interfaces	LAN (communications between the modules and PC) USB Type A (license authentication)
License certification type	USB dongle key (license key)
Recommended PC IP address	192.168.200.5 to 192.168.200.255
Valid PC IP address setting range	Valid IP address setting: 192.168.0.0 to 192.168.255.255 Invalid IP address setting (already reserved): 192.168.200.1 to 192.168.200.4 192.168.201.1 to 192.168.201.6 192.168.202.1 to 192.168.202.6
PC subnet mask settings	255.255.0.0
(3) Other	
Accessories	See p.8.
PC application supply media	USB flash drive

Functional specifications

(1) Impedance measurement

Impedance measurement frequency range	10 mHz to 100 kHz		
EIS Mode (Frequency Sweep)	Measures impedance at multiple user-specified frequencies.		
Logging Mode (Fixed Frequency)	Repeatedly measures impedance at one user-specified frequency. Total measurement time: 1 s to 180 days Logging interval: 1 s, 2 s, 5 s, 10 s, 30 s, 1 min., 2 min., 5 min., 10 min., 30 min., 1 hour Maximum number of repeating measurement points (per channel, per set of measurement conditions): 5000 points		
Impedance measurement method	Real part	$R = U_{sig} / I_{sig} * \cos\theta$	
	Imaginary part	$X = U_{sig} / I_{sig} * \sin\theta$	
	Symbol	R :	Impedance real part [Ω]
		X :	Impedance imaginary part [Ω]
		U_{sig} :	Voltage p-p value [V] for the impedance measurement frequency component
	I_{sig} :	Current p-p value [A] for the impedance measurement frequency component	
	θ :	θ Voltage and current phase difference [$^\circ$]	
Impedance measurement data	ZView [®] (third-party company's trademark) files (.z) Multi-plot files (.csv) ALDAS files (.csv)		

ALDAS file output parameters

System architecture:

ALDAS software version, ALDAS software license, Sense Module model name (serial number), current sensor model name

Measurement conditions:

Measurement mode, measurement speed, noise reduction, signal amplitude, signal DC offset, Sense Module voltage range, Sense Module current range

Common to all measurement channels:

Time and date, measurement elapsed time, frequencies set in measurement conditions

For individual measurement channels:

Frequencies measured, impedance real part, impedance imaginary part, impedance absolute value, impedance phase angle, voltage of impedance measurement frequency component, current of impedance measurement frequency component, DC voltage, DC current

(2) Measurement condition settings**Measurement speed setting**

Fast, Medium, Slow

Length of average processing increases in the following order: Slow > Medium > Fast.

Impedance measurement frequency resolution

Set frequency f [Hz]	Frequency resolution [Hz]
$10000 \leq f \leq 100000$	1000
$1000 \leq f < 10000$	100
$100 \leq f < 1000$	10
$10 \leq f < 100$	1
$1 \leq f < 10$	0.1
$0.1 \leq f < 1$	0.01
$0.01 \leq f < 0.1$	0.001

(3) I-V characteristics measurement**I-V characteristics measurement function**

When impedance measurement is performed, measures the DC current and DC voltage values and displays the DC current and DC voltage measured values when performing impedance under multiple conditions as I-V characteristics.

I-V measurement method

DC current	Measures the DC current before signal superposition.
DC voltage	Measures the DC voltage before signal superposition.

(4) Graph rendering**Impedance graph**

Nyquist (Cole-Cole) Plot	Horizontal axis: Impedance real part Vertical axis: Impedance imaginary part
Bode Plot	Horizontal axis: Frequency Vertical axis: Impedance real part, imaginary part, absolute value, phase angle, current p-p value for impedance measurement frequency component, voltage p-p value for impedance measurement frequency component, current value for DC component, voltage value for DC component (select one)
Logging Plot	Horizontal axis: Measurement time Vertical axis: Impedance real part, imaginary part, absolute value, phase angle, current p-p value for impedance measurement frequency component, voltage p-p value for impedance measurement frequency component, current value for DC component, voltage value for DC component (select one)

I-V graph	I-V Plot (Polarization Curve)	Horizontal axis: DC current Vertical axis: DC voltage
	IR-free Plot	Horizontal axis: DC current Vertical axis: IR-free voltage $V_{IR-free} = V_{dc} - R_{ohm} * I_{dc}$ $V_{IR-free}$: IR-free voltage V_{dc} : DC voltage I_{dc} : DC current R_{ohm} : Ohmic resistance (user-defined)
	I-Power Plot	Horizontal axis: DC current Vertical axis: DC power $P = I_{dc} * V_{dc}$ P : DC power V_{dc} : DC voltage I_{dc} : DC current
	I-Impedance Plot	Horizontal axis: DC current Vertical axis: Maximum frequency resistance (R_{hf}) or minimum frequency resistance (R_{lf}) (select one) R_{hf} : Impedance real part at the highest frequency in the impedance measurement file R_{lf} : Impedance real part at the lowest frequency in the impedance measurement file
Impedance graph maximum number of render points	Depends on the RAM capacity of the PC. When RAM is 16.0 GB or less: 400,000 points When RAM exceeds 16.0 GB: 1,200,000 points	

(5) Alarm function

Sense Module error detection	Current range exceeded	If an input exceeding the current range setting is detected, signal superposition and measurement will stop.
	Voltage range exceeded	If an input exceeding the voltage range setting is detected, signal superposition and measurement will stop.
Source Module error detection	Overvoltage detection	If an overvoltage is detected at the Source Module's signal superposition terminals, signal superposition and measurement will stop.
	Overpower detection	If an overcurrent is detected at the Source Module's signal superposition terminals, signal superposition and measurement will stop.
	Network error detection	If communications between the PC and Source Module are interrupted for 20 seconds or more during measurement operation, signal superposition and measurement will stop.
	Overheat detection	If an overheat condition is detected inside the Source Module, signal superposition and measurement will stop.
	Wiring error detection	If a short or open condition is detected at the Source Module's signal superposition terminals, signal superposition and measurement will stop.
	Reverse connection detection	If a reverse voltage or reverse current is detected at the Source Module's signal superposition terminals, signal superposition and measurement will stop.

(6) Saving of settings data

Saved data	<ul style="list-style-type: none"> • Application settings Project-related files' relative save path, measurement data list, graph settings • Hardware settings Interface and model information for connected devices • Measurement condition settings Measurement frequency, measurement amplitude, hardware settings • Information added to data Graph render information, alert information
Data format	XML format

(7) Saving of measurement data

Saved data	Measurement time and date, elapsed time, set frequency, measurement frequency, impedance real part, impedance imaginary part, voltage of impedance measurement frequency component, current of impedance measurement frequency component, impedance absolute value, impedance phase angle, DC voltage, DC current
Data format	CSV format

11.2 EA5302 Sense Module

General specifications

Operating environment	Indoor use, pollution degree 2, altitude up to 2000 m (6562 ft.)
Operating temperature and humidity range	0°C to 40°C (32°F to 104°F), 80% RH or less (no condensation)
Storage temperature and humidity range	-10°C to 50°C (14°F to 122°F), 80% RH or less (no condensation)
Standards	Safety EN 61010 EMC EN 61326 Class A
Power supply	Grid power Rated supply voltage: AC100 V to 240 V (Assuming voltage fluctuation of $\pm 10\%$) Rated power-supply frequency: 50 Hz/60 Hz Anticipated transient overvoltage: 2500 V Maximum rated power: 150 VA for main unit only
Backup battery life	Lithium batteries: Approx. 10 years (reference value at 23°C) Time/setting conditions
Dimensions	Approx. 430W × 221H × 361D mm (16.9W × 8.7H × 14.2D in.) (excluding protruding parts)
Weight	Approx. 12.7 kg (28.0 lb.) (EA5302-08)
Product warranty duration	1 year
Accessories	See p.8.
Option	See p. 10, p. 11 (Cable for voltage measurement, Products for current measurement)
Repair parts	See p. 11.

Input, output, measurement specifications

(1) Voltage and current measurement shared specifications

No. of input units	Max. 8 units
Sampling	15 MHz, 18 bit
Measurement frequency band	DC, 0.1 Hz to 5 MHz
Effective measurable range	1% to 100% of range

(2) Voltage measurement specifications

Number of input channels	1 channel (EA5302-01) 2 channels (EA5302-02) 4 channels (EA5302-04) 8 channels (EA5302-08)
Input terminal profile	Plug-in terminals (safety terminals)
Input type	Isolated, resistive potential divider
Range	6 V, 15 V, 30 V, 60 V, 150 V, 300 V, 600 V, 1500 V
Crest factor	3 relative to voltage range ratings (however, 1.35 for 1500 V range)
Input resistance, input capacitance	4 M Ω \pm 20 k Ω / 6 pF typical
Maximum input voltage	1000 V, \pm 2000 V peak
Maximum rated voltage to earth	\pm 1000 V

(3) Current measurement specifications

Number of input channels	1 channel (only CH1 enabled)
Input terminal profile	Probe1: Dedicated connector (ME15W)
Input type	Current sensor input method
Range	Probe1: 400 mA, 800 mA, 2 A, 4 A, 8 A, 20 A (with 20 A sensor) 4 A, 8 A, 20 A, 40 A, 80 A, 200 A (with 200 A sensor) 40 A, 80 A, 200 A, 400 A, 800 A, 2 kA (with 2000 A sensor) 1 A, 2 A, 5 A, 10 A, 20 A, 50 A (with 50 A sensor) 10 A, 20 A, 50 A, 100 A, 200 A, 500 A (with 500 A sensor) 100 A, 200 A, 500 A, 1 kA, 2 kA, 5 kA (with 5000 A sensor) 20 A, 40 A, 100 A, 200 A, 400 A, 1 kA (with 1000 A sensor)
Crest factor	3 relative to current range ratings

(4) Impedance measurement specifications

Impedance measurement repeatability

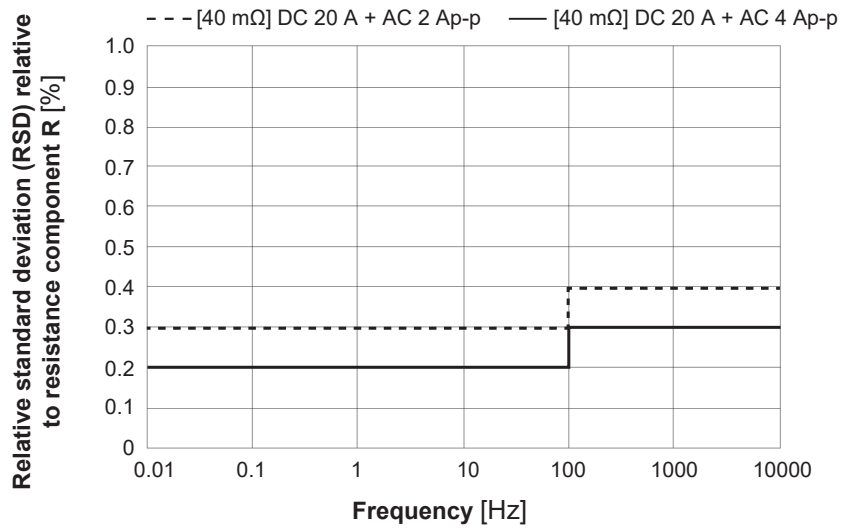

Relative standard deviation of measured resistance value when measuring resistive load (R = 40 mΩ, DC 20 A)

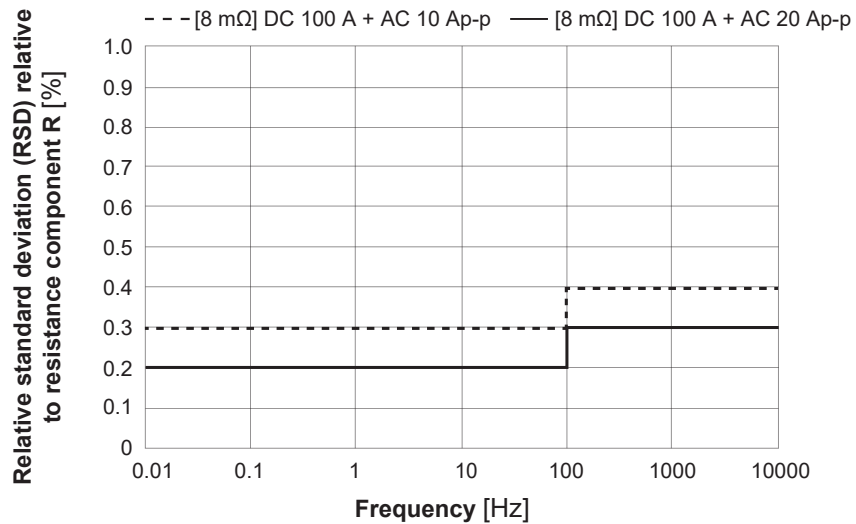

Relative standard deviation of measured resistance value when measuring resistive load (R = 8 mΩ, DC 100 A)

Measurement conditions

Software: EA5702 Electrolysis Cell Analyzer

Voltage range: 6 V

Current sensor: CT6845A

Current range: 20 A range (for DC 20 A), 100 A range (for DC 100 A)

Measurement current: 10%, 20% peak-to-peak current value for sine wave, DC current value

Other settings: FAST measurement speed, noise reduction enabled

No electrical noise

(5) Accuracy specifications

Accuracy guarantee conditions

Accuracy guarantee duration: 1 year

Accuracy guarantee temperature and humidity range: 23°C ±3°C, 80% RH or less

Warm-up time: 30 min. or more

Other: Sine-wave input, power factor of 1 or DC input, line-to-earth voltage of 0 V, within ±1°C after zero adjustment, within accuracy guarantee range

Accuracy guarantee range

1% to 100% of range

Voltage, current, power, and phase angle measurement accuracy

Accuracy	±(% of reading + % of range)	
	Voltage (U)	Current (I)
DC	0.07 % + 0.03 %	0.07 % + 0.03 %
f = 100 Hz	0.02 % + 0.02 %	0.02 % + 0.02 %
100 Hz < f ≤ 440 Hz	0.04% + 0.02%	0.04% + 0.02%
440 Hz < f ≤ 1 kHz	0.05% + 0.04%	0.05% + 0.04%
1 kHz < f ≤ 10 kHz	0.13% + 0.05%	0.13% + 0.05%
10 kHz < f ≤ 50 kHz	0.25% + 0.05%	0.25% + 0.05%
50 kHz < f ≤ 100 kHz	(0.01 × f + 0.2)% + 0.1%	(0.01 × f + 0.2)% + 0.1%

Accuracy	°
	Phase angle (φ) (Phase difference)
f = 100 Hz	±0.15°
100 Hz < f ≤ 440 Hz	±0.15°
440 Hz < f ≤ 1 kHz	±0.15°
1 kHz < f ≤ 10 kHz	±0.72°
10 kHz < f ≤ 50 kHz	(0.020 × f) ±0.7°
50 kHz < f ≤ 100 kHz	(0.030 × f) ±2.4°

- The unit of “f” in the above formula is kHz.
- Voltage and DC current accuracy figures are defined for DC voltage and current. Accuracy figures for frequencies other than DC are defined for RMS values.
- Phase difference accuracy values are defined for 100% input with a power factor of 0.
- For current and phase angle, add the current sensor’s accuracy to the above accuracy figures.
- When using the 6 V range for voltage measurement, add ±0.02% of range to the voltage accuracy.
- When using a range that is 1/10, 1/25, or 1/50 of the current sensor’s rating, add ±0.02% of range to the current accuracy.
- If the temperature varies by ±1°C or more after zero adjustment, add ±0.01% of range per °C to the DC voltage and current accuracy.
- For voltages exceeding 600 V, add the following to the power phase angle accuracy.
 - 100 Hz ≤ f ≤ 500 Hz: ±0.1°
 - 500 Hz < f ≤ 5 kHz: ±0.3°
 - 5 kHz < f ≤ 20 kHz: ±0.5°
 - 20 kHz < f ≤ 100 kHz: ±1°
- For measurement of 800 V or higher, add the following self-heating effect to the voltage/effective power accuracy.
 - ±0.01% of reading
 - The self-heating effect is applied until the input resistance temperature is decreased sufficiently, even if the voltage input value is small.

Effects of temperature	Add the following to the voltage and current accuracy within the range of 0°C to 20°C or 26°C to 40°C. For the DC of ±0.01% of reading per °C, add another 0.01% of range per °C.
-------------------------------	--------------------------------------------------------------------------------------------------------------------------------------------------------------------------------------

Effects of external magnetic fields	±1% of range or less (400 A/m, in DC or 50 Hz/60 Hz magnetic field)
--------------------------------------------	------------------------------------------------------------------------

Functional specifications

(1) Scaling

Functionality	Sets the CT ratio and applies it to measured values.
CT ratio	0.00001 to 9999.99

(2) Current sensor phase correction

Functionality	Corrects current sensor high-frequency phase characteristics in calculations.
Operating modes	OFF, ON, AUTO The AUTO setting can be selected when a current sensor that supports the automatic detection function is connected.
Correction value setting	Sets the frequency and phase difference for correction points. Frequency: 0.1 kHz to 5000.0 kHz (0.1 kHz increments) Phase difference: 0.000 deg to ± 180.000 deg (0.001 deg increments) When the operating mode is set to AUTO, these settings are configured automatically when a sensor is connected.

Interface specifications

(1) LAN

Number of ports	1 port
Connector	RJ-45 8-pole
Rating/method	IEEE 802.3ab compliant
Transmission method	1000Base-T auto negotiation
Protocol	TCP/IP
Communication details	Settings and inquiries with communication commands from the PC application for the electrolysis cell analyzer

11.3 EA5502 Source Module

General specifications

Operating environment	Indoor use, pollution degree 2, altitude up to 2000 m (6562 ft.)
Operating temperature and humidity range	0°C to 40°C (32°F to 104°F), 80% RH or less (no condensation)
Storage temperature and humidity range	-10°C to 50°C (14°F to 122°F), 80% RH or less (no condensation)
Standards	See "Safety" and "Electromagnetic Compatibility (EMC)" for "General specifications" in the PLZ4005WH2 instruction manual.
Power supply	Grid power Rated supply voltage: AC 100 V to 240 V (Assuming voltage fluctuation of ±10%) Rated power-supply frequency: 50 Hz, 60 Hz Anticipated transient overvoltage: 2500 V Maximum rated power: 150 VA for main unit only
Backup battery life	Lithium batteries: Approx. 3 years (reference value at 23°C) Time/setting conditions
Dimensions	Approx. 429.5W × 128H × 500D mm (16.9W × 5.0H × 19.7D in.) (excluding protruding parts)
Weight	Approx. 20 kg (44.1 lbs)
Product warranty duration	1 year
Accessories	See p.8.
Option	See p. 10 (Cable for signal superposition).
Repair parts	See p. 11.

Input, output, measurement specifications

(1) Signal source specifications

Source operation method	Electronic load
Load operating modes	Constant-current (CC)

Signal superposition method Signal superposition by drawing some of the DC current flowing to the measurement target to the Source Module (See figure below.)

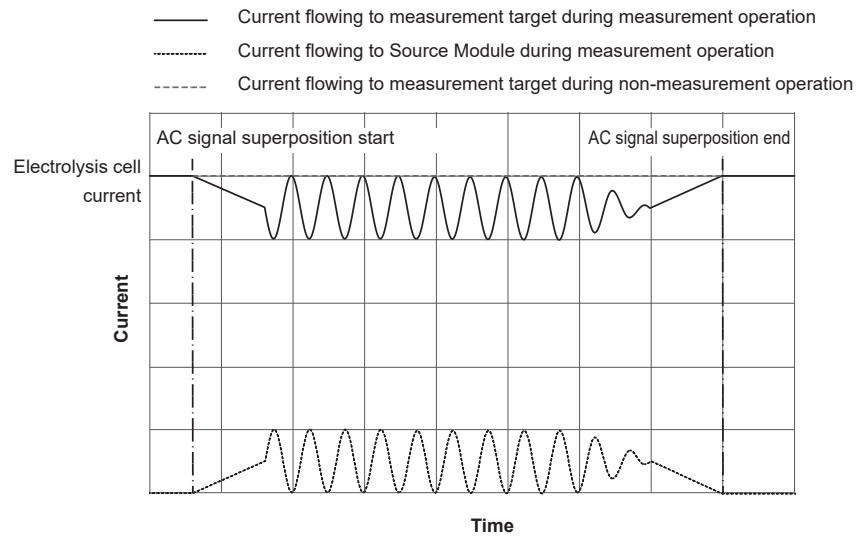

Diagram of current applied to measurement target during measurement

Load input terminal profile	Bus-bar with M10 bolt hole Tightening torque: 22.4 N·m
Maximum input voltage	DC 0 V to 1000 V
Rated current	80 A
Rated power	4000 W
Operating voltage	DC 10 V to 1000 V
Minimum operating voltage	At rated current: 10 V At current flow: 1.5 V or less
Maximum rated voltage to earth for load input terminal	Positive terminal: ±1000 V Negative terminal: ±900 V
Signal source frequency band	10 kHz (-3 dB Typical)
Slew rate	4 A/μs (Typical)
Resolution	0.002A EA5702 Setting range : 0.01 A

Interface specifications

(1) LAN

Number of ports	1 port
Connector	RJ-45 8-pole
Rating/method	IEEE 802.3 compliant
Transmission method	100Base-TX Ethernet
Communication details	Settings and inquiries with communication commands from the PC application for the EA5702 Electrolysis Cell Analyzer

EA5502 operation range

As shown in the figures below, this product can be used within the range (specification warranty operation range) enclosed with the constant voltage line (L1) at the rated voltage, constant power line (L2) at the rated power, constant current line (L3) at the rated current, and constant voltage line (L4) at the minimum operation voltage. The specification is guaranteed at an input voltage of 10 V or higher. The product can still be used at a voltage less than 10 V (actual operation range) by decreasing the current. Note, however, that the specification is not guaranteed in this case. At the start of current flow to this product, the voltage is approximately 1.5 V. When the input voltage is gradually increased from 0 V, the current only starts flowing after the input voltage exceeds approximately 1.5 V. Once a current over 1% of the rated current starts flowing after the input voltage has exceeded approximately 1.5 V, the current continues to flow even when the input voltage drops.

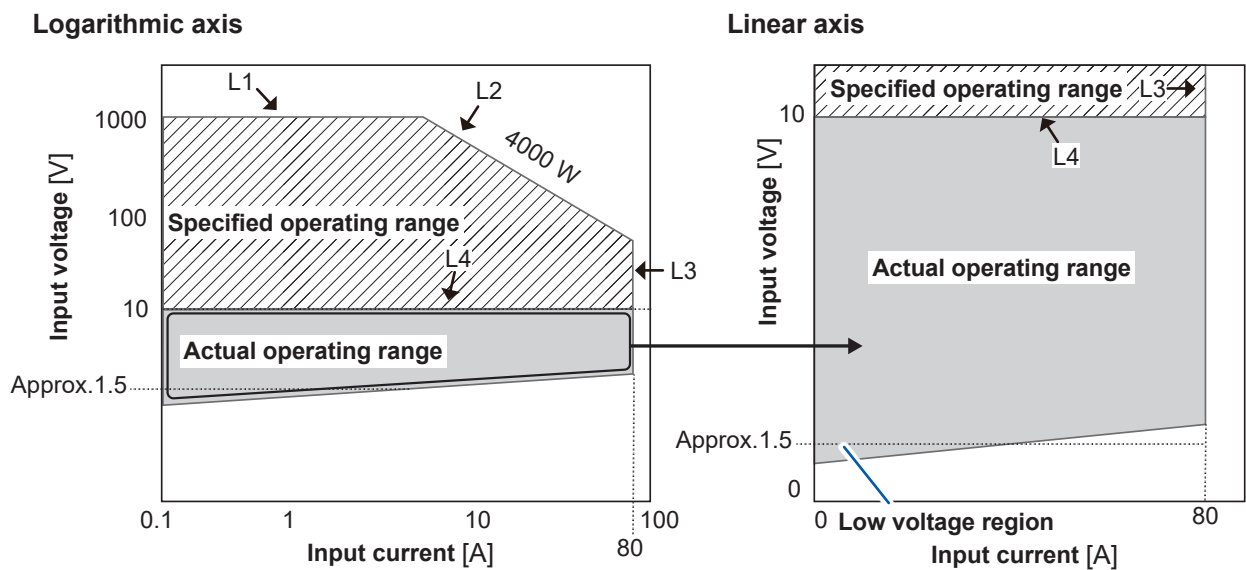

11.4 EA5901 Control Module

General specifications

Operating environment	Indoor use, pollution degree 2, altitude up to 2000 m (6562 ft.)
Operating temperature and humidity range	0°C to 40°C (32°F to 104°F), 80% RH or less (no condensation)
Storage temperature and humidity range	-10°C to 50°C (14°F to 122°F), 80% RH or less (no condensation)
Standards	Safety: EN 61010 EMC: EN 61326 Class A
Power supply	Grid power Rated supply voltage: AC 100 V to 240 V (Assuming voltage fluctuation of $\pm 10\%$) Rated power-supply frequency: 50 Hz, 60 Hz Anticipated transient overvoltage: 2500 V Maximum rated power: 60 VA for main unit only At the maximum load applied to the power supply output port: 965 VA
Dimensions	Approx. 430W × 88H × 350D mm (16.9W × 3.5H × 13.8D in.) (excluding protruding parts)
Weight	Approx. 6.1 kg (13.4 lbs)
Product warranty duration	1 year
Accessories	See p. 8.
Option	<ul style="list-style-type: none"> • Z5411 Rack cabinet (13U) • Z5412 Rack cabinet (19U) • Z5413 Rack cabinet (24U)
Repair parts	See p. 11.

System specifications

(1) Power outlet

Number of power outlets	For Sense Module: 3 outlets For Source Module: 2 outlets For CT9557: 1 outlet
Power feeding specifications	Distributed from power supply inlet Rated supply voltage: AC 100 V to 240 V (Assuming voltage fluctuation of $\pm 10\%$) Rated power-supply frequency: 50 Hz, 60 Hz Maximum rated power: <ul style="list-style-type: none"> • For Sense Module: 150 VA per outlet (total power: 450 VA) • For Source Module: 150 VA per outlet (total power: 300 VA) • For CT9557: 155 VA

(2) LAN interface

Number of ports	For PC: 1 port For Sense Module: 3 ports For Source Module: 1 port For additional rack: 1 port
Connector	RJ-45 8-pole (shielded type)
Cable specifications	STP LAN cable
Rating/method	IEEE 802.3ab compliant
Transmission method	1000Base-T auto negotiation
Protocol	TCP/IP
Communication details	Settings and inquiries with communication commands from the PC application for the electrolysis cell analyzer

Input, output, measurement specifications**(1) Basic specifications: Source Module control signal output**

Number of output channels	1 channel
Output terminal profile	Insulated BNC
Functionality	Source Module control
Insulation	Insulated from main unit chassis GND
Output format	Unbalanced output (floating)
Maximum output voltage	± 10 V
Maximum output current	± 5 mA
Allowable load resistance	2 k Ω or more
Output resistance	When output is on: 30 Ω (Typical) When output is off: 10 M Ω or more
Output frequency	Setting range: 0 Hz to 100 kHz (sine wave) Resolution setting: 10 mHz
Amplitude	Setting range: 0 Vp-p to 20 Vp-p Resolution setting: 0.5 mVp-p
DC offset	Setting range: ± 10 V Resolution setting: 0.5 mV
Maximum rated voltage to earth	DC ± 500 V (output channel - main unit chassis GND)

Functional specifications

(1) LED display

POWER	Functionality	Lit	Power on
		Blinking	Warm-up
		Off	Power off
	LED color	Green	
MEAS	Functionality	Lit	Measurement underway
		Off	Measurement stop
	LED color	Green	
ERROR	Functionality	Lit	Error activated
		Off	No error
	LED color	Orange	

11.5 Z5405 Sensor Branch Module

General specifications

Operating environment	Indoor use, pollution degree 2, altitude up to 2000 m (6562 ft.)
Operating temperature and humidity range	0°C to 40°C (32°F to 104°F), 80% RH or less (no condensation)
Storage temperature and humidity range	-10°C to 50°C (14°F to 122°F), 80% RH or less (no condensation)
Standards	Safety: EN 61010
Dimensions	Approx. 96W × 47H × 77D mm (3.8W × 1.9H × 3.0D in.)
Weight	Approx. 180 g (6.3 oz.)
Product warranty duration	1 year
Accessories	<ul style="list-style-type: none"> • Download Guide ×1 • Operating Precautions (0990A903) ×1
Option	CT9904 Connection Cable (1 m)
Applicable current sensor	<p>Current sensor with Hioki's ME15W (male) for its output connector</p> <ul style="list-style-type: none"> • CT6841A AC/DC Current Probe (20 A) • CT6843A AC/DC Current Probe (200 A) • CT6844A AC/DC Current Probe (500 A) • CT6845A AC/DC Current Probe (500 A) • CT6846A AC/DC Current Probe (1000 A) • CT6872 AC/DC Current Sensor (50 A) • CT6873 AC/DC Current Sensor (200 A) • CT6875A AC/DC Current Sensor (500 A) • CT6876A AC/DC Current Sensor (1000 A) • CT6877A AC/DC Current Sensor (2000 A) • CT6904A AC/DC Current Sensor (500 A) • CT9557 Sensor Unit
Connectable devices	<p>Device with Hioki's ME15W (female) for its sensor input section</p> <ul style="list-style-type: none"> • EA5301-0x Sense Module • EA5302-0x Sense Module

Input and output specifications

Input connector (front)	Hioki's ME15W (female)									
Output connector (rear)	Hioki's ME15W (male) × 3 channels									
Accuracy guarantee conditions	Accuracy guarantee temperature and humidity range: 23°C ±5°C, 80 % RH or less									
Combination accuracy	Add the following to the accuracy of the current sensor to be connected.									
	<table border="1"> <thead> <tr> <th>Frequency</th> <th>Amplitude</th> <th>Phase</th> </tr> </thead> <tbody> <tr> <td>DC < f ≤ 1 kHz</td> <td>±0.1%</td> <td>±0.05°</td> </tr> <tr> <td>1 kHz < f ≤ 100 kHz</td> <td>±0.1%</td> <td>± (0.05 + 0.005 × f kHz)°</td> </tr> </tbody> </table>	Frequency	Amplitude	Phase	DC < f ≤ 1 kHz	±0.1%	±0.05°	1 kHz < f ≤ 100 kHz	±0.1%	± (0.05 + 0.005 × f kHz)°
Frequency	Amplitude	Phase								
DC < f ≤ 1 kHz	±0.1%	±0.05°								
1 kHz < f ≤ 100 kHz	±0.1%	± (0.05 + 0.005 × f kHz)°								
	Accuracy calculation method for branch output waveform Accuracy = (accuracy of current sensor) + (combination accuracy)									

Functional specifications

Current sensor rating setting switch Set either H or L for each switch according to the rated current of the current sensor to be connected.
See "10.3 Current Sensor Rating Setting (Switch)" (p. 106)



Current sensor rating setting switch

11.6 L1101, L1101-01 Sense Cable

General specifications

Operating environment	Indoor use, pollution degree 2, altitude up to 2000 m (6562 ft.)		
Operating temperature and humidity range	-10°C to 50°C (14°F to 122°F), 80% RH or less (no condensation)		
Storage temperature and humidity range	-20°C to 60°C (-4°F to 140°F), 80% RH or less (no condensation)		
Standards (Safety)	Cable:	EN 61010	
	Alligator clip:	EN 61010	
Dimensions	L1101	Cable:	Full length approx. 2135 mm (84.1 in.)
		Alligator clip:	(including plug length) Full length approx. 83.5 mm (3.3 in.)
	L1101-01	Cable:	Full length approx. 3000 mm (118.1 in.)
		Alligator clip:	(including plug length) Full length approx. 83.5 mm (3.3 in.)
Weight	L1101	Cable:	Approx. 200 g (7.1 oz.)
		Alligator clip:	Approx. 40 g (1.4 oz.) (a set of red and black cables)
	L1101-01	Cable:	Approx. 280 g (9.9 oz.)
		Alligator clip:	Approx. 40 g (1.4 oz.) (a set of red and black cables)
Maximum input voltage	DC 1000 V /AC 1000 V		
Maximum rated voltage to earth	1000 V (Measurement category III) 600 V (Measurement category IV) Anticipated transient overvoltage: 8000 V		
Maximum input current	10 A		

11.7 L1151, L1151-01 Source Cable

General specifications

Operating environment	Indoor use, pollution degree 2, altitude up to 2000 m (6562 ft.)	
Operating temperature and humidity range	0°C to 40°C (32°F to 104°F), 80% RH or less (no condensation)	
Storage temperature and humidity range	-10°C to 50°C (14°F to 122°F), 80% RH or less (no condensation)	
No. of cables	2 (one for high, the other for low)	
Dimensions	L1151	Full length approx. 2100 mm (82.7 in.)
	L1151-01	Full length approx. 3000 mm (118.1 in.)
Weight	L1151	Approx. 2280 g (80.4 oz.)
	L1151-01	Approx. 3250 g (114.6 oz.)
Terminal	Round crimp terminal for M10 bolt size (High and low is identified by red and black insulation caps) Inner diameter: 10.5 mm Stud diameter: M10 (3/8)	
Maximum input voltage	DC 1000 V /AC 1000 V	
Maximum rated voltage to earth	DC 1000 V /AC 1000 V	
Maximum input current	AC/DC 100 A	

11.8 Z5411 Rack Cabinet

General specifications

Operating environment	Indoor use, pollution degree 2, altitude up to 2000 m (6562 ft.)
Operating temperature and humidity range	0°C to 40°C (32°F to 104°F), 80% RH or less (no condensation)
Storage temperature and humidity range	-10°C to 50°C (14°F to 122°F), 80% RH or less (no condensation)
19-inch standards	EIA standards
Effective rack height	13U
Dimensions	Approx. 570W × 860H × 650D mm (22.4W × 33.9H × 25.6D in.) (including casters, excluding protruding parts)
Weight	Approx. 44 kg (97.0 lbs) (excluding blank panels)
Rack configuration (Described from the top in order)	See “Z5411 Rack Cabinet Configuration” (p. 143).
Accessories	<ul style="list-style-type: none"> • Z7048 Blank Panel (for 3U) ×2, already attached to the rack • Z7050 Anchor Brackets (4 pcs.) ×1 set
Option	Z7048 Blank Panel (for 3U)
Repair parts	Z7050 Anchor Brackets (4 pcs.) ×1 set

11.9 Z5412 Rack Cabinet

General specifications

Operating environment	Indoor use, pollution degree 2, altitude up to 2000 m (6562 ft.)
Operating temperature and humidity range	0°C to 40°C (32°F to 104°F), 80% RH or less (no condensation)
Storage temperature and humidity range	-10°C to 50°C (14°F to 122°F), 80% RH or less (no condensation)
19-inch standards	EIA standards
Effective rack height	19U
Dimensions	Approx. 570W × 1100H × 650D mm (22.4W × 43.3H × 25.6D in.) (including casters, excluding protruding parts)
Weight	Approx. 50 kg (110.2 lbs) (excluding blank panels)
Rack configuration (Described from the top in order)	See “Z5412 Rack Cabinet Configuration” (p. 143).

Accessories	<ul style="list-style-type: none"> • Z7047 Blank Panel (for 1U) ×1, already attached to the rack • Z7048 Blank Panel (for 3U) ×2, already attached to the rack • Z7050 Anchor Brackets (4 pcs.) ×1 set
Option	Z7047 Blank Panel (for 1U) Z7048 Blank Panel (for 3U) Z7049 Blank Panel (for 5U)
Repair parts	Z7050 Anchor Brackets (4 pcs.) ×1 set

11.10 Z5413 Rack Cabinet

General specifications

Operating environment	Indoor use, pollution degree 2, altitude up to 2000 m (6562 ft.)
Operating temperature and humidity range	0°C to 40°C (32°F to 104°F), 80% RH or less (no condensation)
Storage temperature and humidity range	-10°C to 50°C (14°F to 122°F), 80% RH or less (no condensation)
19-inch standards	EIA standards
Effective rack height	24U
Dimensions	Approx. 570W × 1360H × 650D mm (22.4W × 53.5H × 25.6D in.) (including casters, excluding protruding parts)
Weight	Approx. 62 kg (136.7 lbs) (excluding blank panels)
Rack configuration (Described from the top in order)	See “Z5413 Rack Cabinet Configuration” (p. 144).
Accessories	<ul style="list-style-type: none"> • Z7047 Blank Panel (for 1U) ×1, already attached to the rack • Z7048 Blank Panel (for 3U) ×2, already attached to the rack • Z7050 Anchor Brackets (4 pcs.) ×1 set
Option	Z7047 Blank Panel (for 1U) Z7048 Blank Panel (for 3U) Z7049 Blank Panel (for 5U)
Repair parts	Z7050 Anchor Brackets (4 pcs.) ×1 set

12 Maintenance and Service

12.1 Repairs, Inspections, and Cleaning

WARNING



- **Do not attempt to modify, disassemble, or repair the Sense Module or Source Module yourself.**

Failure to follow this guidance could cause bodily injury or fire.

CAUTION



- **If the protective function of the system is damaged, arrange for immediate repair or dispose of it. If storage is unavoidable, label it as damaged.**

Failure to follow this guidance could cause bodily injury.

IMPORTANT

Stop using this product in the following cases:

- It is obvious that the product is damaged.
- Measurement cannot be performed.
- The product has been stored for a long period under inappropriate conditions, such as where the temperature and humidity were high.
- Excessive stress has been applied to the product during rough shipping.
- The product is wet or heavily contaminated with oil or dust (if the product is wet, or oil or dust enters the inside of the system, insulation will deteriorate, possibly causing electrical shocks or fire).
- The measurement conditions cannot be saved.

Calibration

The appropriate schedule for calibration depends on factors such as the operating conditions and environment. Determine the appropriate calibration interval based on your operating conditions and environment, and have Hioki calibrate the instrument accordingly.

Backing up data

When repairing or calibrating the system, we may initialize it. It is recommended to back up (save/write) data, such as the settings and measured data, before requesting service.

IMPORTANT

If requesting calibration service from Hioki, please send only the Sense Module.

Replaceable parts and service life

IMPORTANT

Heat could be generated excessively inside the EA5502 Source Module.

It is recommended to overhaul the system once every 10,000 hours of operation when you inspect or clean the inside of the system. However, overhaul the product as necessary depending on the usage conditions. Contact your authorized Hioki distributor or reseller.

Some parts used in the products may deteriorate in characteristics after years of use.

It is recommended to replace these parts regularly to ensure long-term functionality.

To order replacements, please contact your authorized Hioki distributor or reseller.

Part service life varies with the operating environment and frequency of use. Recommended replacement intervals do not guarantee continuous operation throughout the specified period.

Parts	Service life	Remarks and conditions
EA5302 Sense Module		
Electrolytic capacitor	About 10 years	Requires replacement of the printed circuit boards on which such parts are mounted.
Liquid crystal back-light (half life period of brightness)	About 8 years	If operated 24 hours per day
Fan motor	About 10 years	If operated 24 hours per day
Backup battery	About 10 years	Requires replacement if the time and date are significantly deviated.
Optical insulation element	About 10 years	If operated 24 hours per day
Optical connection cable connector	About 10 years	If operated 24 hours per day
EA5502 Source Module		
Electrolytic capacitor	About 5 years	Whether it is necessary to replace the board is checked at the time of overhaul.
Fan motor	About 4 years	If operated 24 hours per day with the maximum load Whether it is necessary to replace the motor is checked at the time of overhaul.
Backup battery	About 3 years	If operated 24 hours per day
EA5901 Control Module		
Electrolytic capacitor	About 10 years	Requires replacement of the printed circuit boards on which such parts are mounted.
Fan motor	About 10 years	If operated 24 hours per day

Cleaning

CAUTION

- **Periodically clean the vents.**
Clogged vents could hamper the internal cooling effect of the modules, causing damage to them.
- **To clean the products, wipe them using a soft cloth moistened with water or a neutral detergent.**
Using solvent-containing detergents, such as benzene, alcohol, acetone, ether, ketone, thinner, and gasoline, or wiping the products with excessive force could cause deformation or discoloration.

IMPORTANT

Dirt on the Sense Cable or Source Cable clips should be removed gently with a dry and clean soft cloth or with an industrial-use cotton swab. The presence of any foreign material, such as dirt, on the clips can hinder their ability to make proper contact, thus adversely affecting the measurement results.

Gently wipe the displays of the Sense Module and Source Module with a soft and dry cloth.

12.2 Troubleshooting

Should you identify any problems, refer to “Before returning the products for repair” (p. 132) and “12.3 Error Messages” (p. 134) to address the issues. If further assistance is needed, contact your authorized Hioki distributor or reseller.

Before returning the products for repair

Check the following items.

Issue	Cause	Solution
The modules does not turn on.	The power cords are not connected or not properly connected.	Connect the power cords properly. See “13.3 Connecting the Power Cords and LAN Cables” (p. 148).
The PC application does not start.	The USB dongle key is not connected to the PC.	Connect the USB dongle key to the PC. See “3.1 Inserting a USB Dongle Key into the PC” (p. 55).
The PC cannot connect to the system instruments.	The LAN cables are not connected or not properly connected.	Connect the LAN cable between modules and PC properly. See “13.3 Connecting the Power Cords and LAN Cables” (p. 148).
	The PC’s IP address setting is not configured properly.	Configure the PC’s IP address properly. See “2.3 Setting the IP Address of Each Device” (p. 38).
	No current sensor is connected.	Verify that the current sensor is properly connected to CH1 of the Sense Module. See “2.7 Connecting the Current Sensor (Current Input)” (p. 46).
Communications between the PC and modules were interrupted.	The modules have hung.	<ul style="list-style-type: none"> • Reconnect the modules to PC. • Relaunch the PC application. • Restart the system.
Voltage and current measurement values are abnormal. Measured values were unstable.	The Sense Cable, Source Cable, and current sensor are not connected properly.	Verify that the Sense Cable, Source Cable, and current sensor are connected properly. To achieve more stable measurements, see “Methods for stabilizing measurement” (p. 158).
	The voltage range and current range are not configured properly.	Configure the voltage range and current range properly. See “Configuring the Sense Module” (p. 67).
	The current sensor’s phase correction setting is not configured properly.	Configure the current sensor’s phase correction setting (for the selected current sensor model) properly. See “Configuring the Sense Module” (p. 67).
	The measurement signal amplitude is too small.	Check the measurement value, and if the I _{sig} is extremely small, please increase [Signal Amplitude] value in the measurement condition setting. See “Configuring the Sense Module” (p. 67).

Issue	Cause	Solution
<p>The PC application was slow, making measurement impossible.</p>	<p>The data is too large because there are many measurement points plotted on the graph.</p>	<p>Data is saved as a CSV format file in the [DataFiles] folder inside the project folder. If you do not need to compare the data, perform measurement with separate project file that contains no measurement data.</p>
<p>Measurement was aborted.</p>	<p>The PC went to sleep during measurement.</p>	<p>Configure the PC so that it does not go into sleep-mode.</p>

12.3 Error Messages

- If an error appears on the display, inspection or repair is required. Contact your authorized Hioki distributor or reseller.
- If the measurement target is energized before turning on the power supply to this system, the system may malfunction or display an error when powered on. Always turn on the system's power supply first and confirm that no error is displayed before energizing the measurement target.

EA5302 Sense Module

Error messages

Message	Solution
The optional adjustment data is corrupted.	Repair is necessary. Contact your authorized Hioki distributor or reseller.
The option configuration is not correct.	Repair is necessary. Contact your authorized Hioki distributor or reseller.
The unit adjustment data is corrupted.	Repair is necessary. Contact your authorized Hioki distributor or reseller.
The unit ID setting is incorrect.	Repair is necessary. Contact your authorized Hioki distributor or reseller.
The settings on the main unit have been initialized.	If this message frequently appears, repair may be necessary. Contact your authorized Hioki distributor or reseller.
The fan is broken.	Repair is necessary. Contact your authorized Hioki distributor or reseller.
The unit communication section is malfunctioning.	Repair is necessary. Contact your authorized Hioki distributor or reseller.
The optical link module is faulty. Please restart the device.	Turn the power to the system back on. If this message frequently appears, contact your authorized Hioki distributor or reseller.

Warning message

Message	Solution
The current sensor was changed.	Tap the button to close the message.

PC application

If a measurement system error occurs, a dialog box including an error message will be displayed by the PC application.

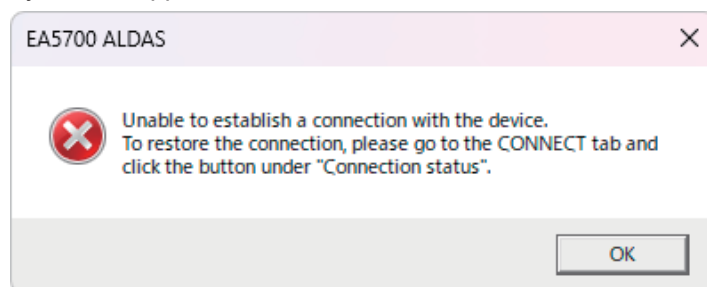

Address the issue described in the following error messages.

Message	Solution
The measurement stopped because the measured current exceeded the measurable current range. Please go to the MEASURE tab and set the suitable current range.	Edit the measurement conditions and set the current range to an appropriate value. See "Configuring the Sense Module" (p.67).
The measurement stopped because the measured voltage exceeded the measurable voltage range. Please go to the MEASURE tab and set the suitable voltage range.	Edit the measurement conditions and set the voltage range to an appropriate value. See "Configuring the Sense Module" (p.67).
The measurement stopped because reverse voltage was detected at the Source Module's signal superposition terminal. Please turn off the power to the device and check the connection status between the Source Cable and the DUT.	Turn off power to the measurement target and Source Module and check whether the Source Cable is connected to the measurement target with the proper polarity* ¹ *1. The Source cable's red clip should be connected to the positive (high-potential) side, and the black clip should be connected to the negative (low-potential) side. See "2.10 Connecting to the Measurement Target" (p.51).
The measurement stopped because the voltage signal detected at the Source Module's signal superposition terminal was lower than the operating range. Please turn off the power to the device and check the connection status between the Source Cable and the DUT.	Turn off power to the measurement target and Source Module and check whether the Source Cable is connected to the measurement target with the proper polarity* ¹ *1. The Source cable's red clip should be connected to the positive (high-potential) side, and the black clip should be connected to the negative (low-potential) side. See "2.10 Connecting to the Measurement Target" (p.51).
The measurement stopped due to a communication failure with the device. To restore the connection, please go to the CONNECT tab and click the button under "Connection status".	1. Please check the condition of the LAN cable connection. See "Connecting the LAN cables" (p.150). 2. Open the connection setting (CONNECT) tab and reconnect the devices. See "8.1 Checking the System Connection Status and Reconnection" (p.89).
The measurement stopped because the watchdog protection was activated. To restore the connection, please go to the CONNECT tab and click the button under "Connection status".	
The measurement stopped because the current sensor in the Sense Module was changed. Please go to the MEASURE tab and check the setting for the Sense Module.	Edit the measurement conditions and set appropriate values for the current sensor and current range. See "Configuring the Sense Module" (p.67)

Message	Solution
<p>The measurement stopped because an overvoltage was detected at the Source Module's signal superposition terminal. Please check if the DUT's voltage is within the rated value.</p>	<p>Confirm that the High-Low voltage of the Source Cable connected to the measurement target does not exceed the maximum input voltage specification of the Source Module. See "11.3 EA5502 Source Module" (p. 117).</p>
<p>The measurement stopped because excessive power was detected at the Source Module's signal superposition terminal. Please go to the MEASURE tab and set a suitable signal amplitude and DC offset.</p>	<p>Perform settings so that the load power calculated from the voltage and amplitude of the measurement signal for the measurement target does not exceed the rated power specification of the Source Module. See "11.3 EA5502 Source Module" (p. 117).</p>
<p>The measurement stopped because an overcurrent was detected at the Source Module's signal superposition terminal. Please check the condition of the Source Cable connection.</p>	<p>Verify that the Source Cable is properly connected to the measurement target. See "2.10 Connecting to the Measurement Target" (p. 51).</p>
<p>The measurement stopped because an error occurred in the device. Please restart the device.</p>	<ol style="list-style-type: none"> 1. Please check the condition of the LAN cable connection. See "13.3 Connecting the Power Cords and LAN Cables" (p. 148). 2. Restart the device using the start/stop switch of the Control Module. See "2.8 Supplying Power" (p. 48).
<p>The measurement stopped because the device has entered an abnormal state. Please restart the device.</p>	
<p>The measurement stopped due to an external error in the device. Please restart the device.</p>	
<p>The measurement stopped because the Source Module shut down. Please restart the device.</p>	
<p>The measurement stopped because the Source Module overheated. Please check the Source Module installation and verify that the vent is not obstructed.</p>	<p>Turn off the Source Module and verify that its air vent is not blocked. Ensure that the Source Module is positioned far from nearby objects (see minimum space requirements). After checking these points, leave the Source Module powered on for at least 30 minutes before use to allow the fan to cool it down before use. See "Precautions for Use" (p. 17).</p>

12.4 Disposal of the Products

When disposing of the products, remove the lithium batteries and dispose of the batteries in accordance with local regulations. Dispose of all optional accessories in accordance with applicable instructions.

WARNING

- Do not short-circuit the batteries.
- Do not charge the Battery Pack.
- Do not disassemble the Battery Pack.
- Do not incinerate or heat it.



Failure to follow this guidance could cause the batteries to explode, resulting in bodily injury.

- **Before removing the lithium batteries, first set the switches of the modules to the off position and then remove the power cords and the measurement cables from the measurement target.**



Failure to follow this guidance could result in electric shock.

- **Store the removed batteries out of reach of young children.**

Failure to follow this guidance could lead to accidental ingestion of a battery by young children.

CALIFORNIA, USA ONLY
Perchlorate Material - special handling may apply.
See <https://dtsc.ca.gov/perchlorate/>.

13

Embedding Devices into the Rack Cabinet

13.1 Preparations

Removing the support legs and attaching the rack mount fittings

⚠ WARNING



- Use the M4 × 8 mm screws for attaching the rack mount fittings to the main unit.

Using any other screws could damage the instrument, resulting in bodily injury.

EA5901 Control Module

Items to prepare: Z7046 Rack Mount Fittings (EIA-compatible), flat-blade screwdriver, Phillips screwdriver (No. 2)

- 1** Place the modules with its bottom facing upward, and remove the rubber caps of the support legs (at four locations) by hooking them with a flat-blade screwdriver.
When you remove the rubber cap, you will see a screw inside.
- 2** Use a Phillips screwdriver to remove the four screws from the support legs, and then detach the support legs.
- 3** Remove the screws from the left and right sides.
Store the removed rubber caps, screws, and support legs.

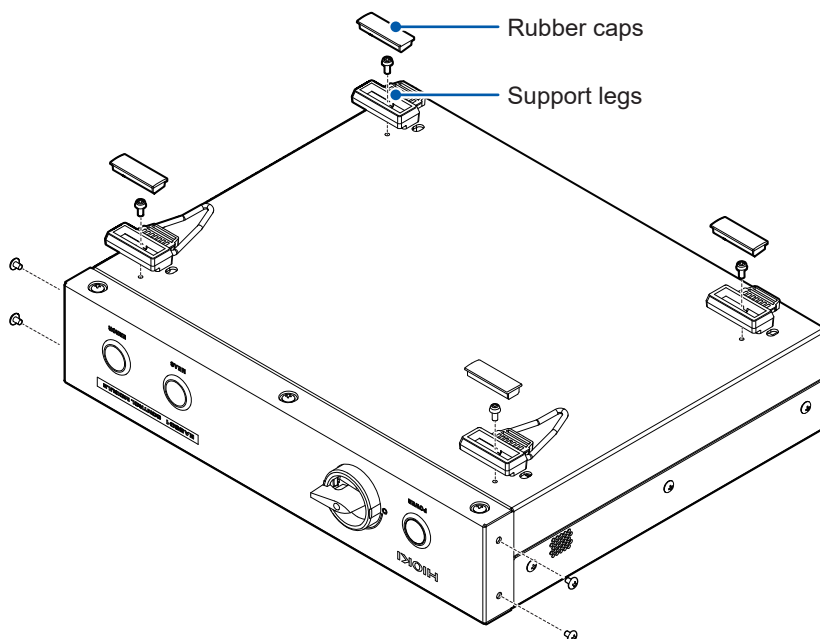

- 4 Attach the Z7046 Rack Mount Fittings to the main unit using M4 × 8 screws (two pcs. each on the left and right).

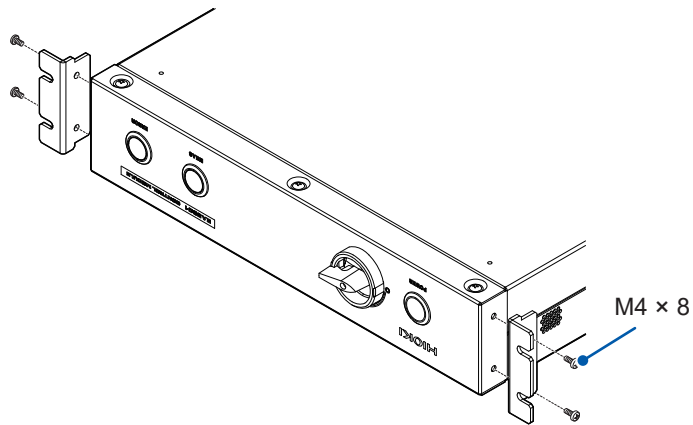

EA5302 Sense Module

Items to prepare: Z7044 Rack Mount Fittings (EIA-compatible), flat-blade screwdriver, Phillips screwdriver (No. 2)

- 1 Place the modules with its bottom facing upward, remove each support leg (at four locations) by hooking a flat-blade screwdriver under the edge of the rubber cap.

When you remove the rubber cap, you will see a screw inside.

- 2 Use a Phillips screwdriver to remove the four screws from the support legs, and then detach the support legs.

Store the removed rubber caps, screws, and support legs.

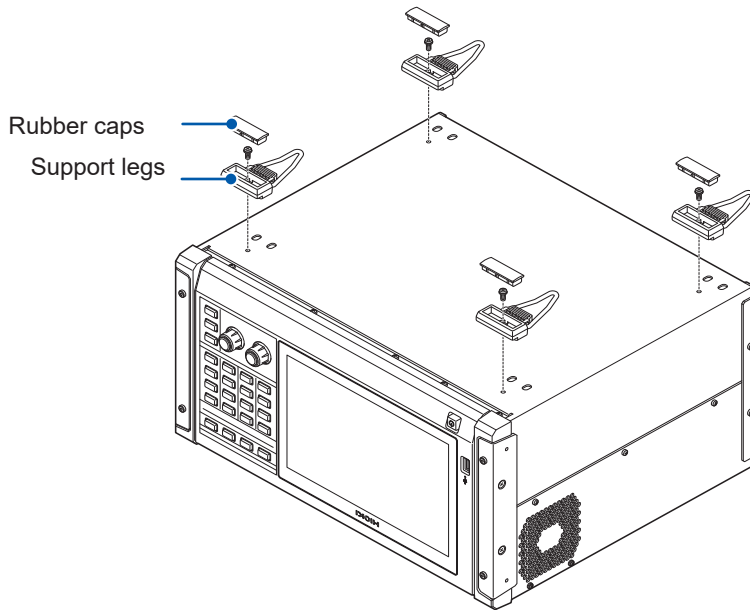

- 3 Attach the Z7046 Rack Mount Fittings to the main unit using M4 × 8 screws (two pcs. each on the left and right).

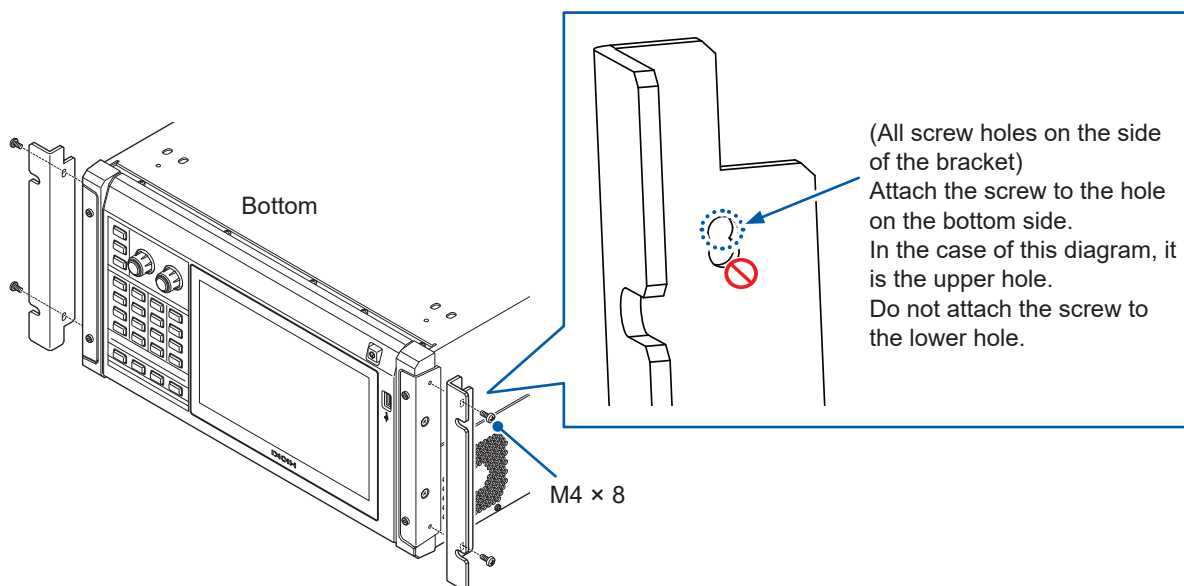

EA5502 Source Module

Items to prepare: Z7045 Rack Mount Fittings (EIA-compatible), Flat-blade screwdriver, Phillips screwdriver (No. 2)

- 1** Place the modules with its bottom facing upward, and while pulling the support feet (4 locations) upward, use a flat-blade screwdriver to loosen the screw pins and remove the support feet.

Store the removed support legs and screw pins.

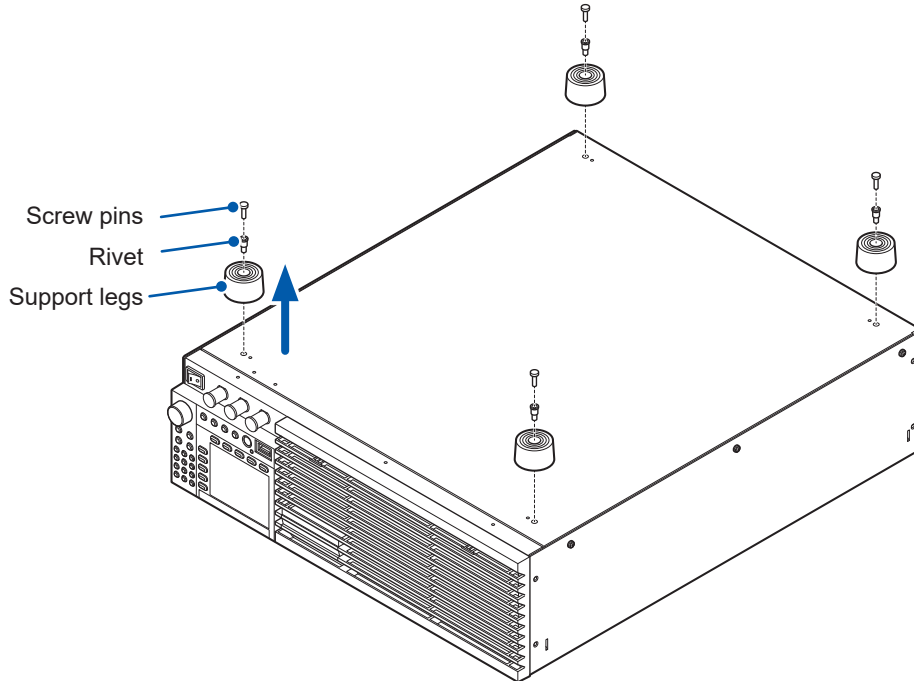

- 2** Attach the Z7046 Rack Mount Fittings to the main unit using M4 × 8 screws (two pcs. each on the left and right).

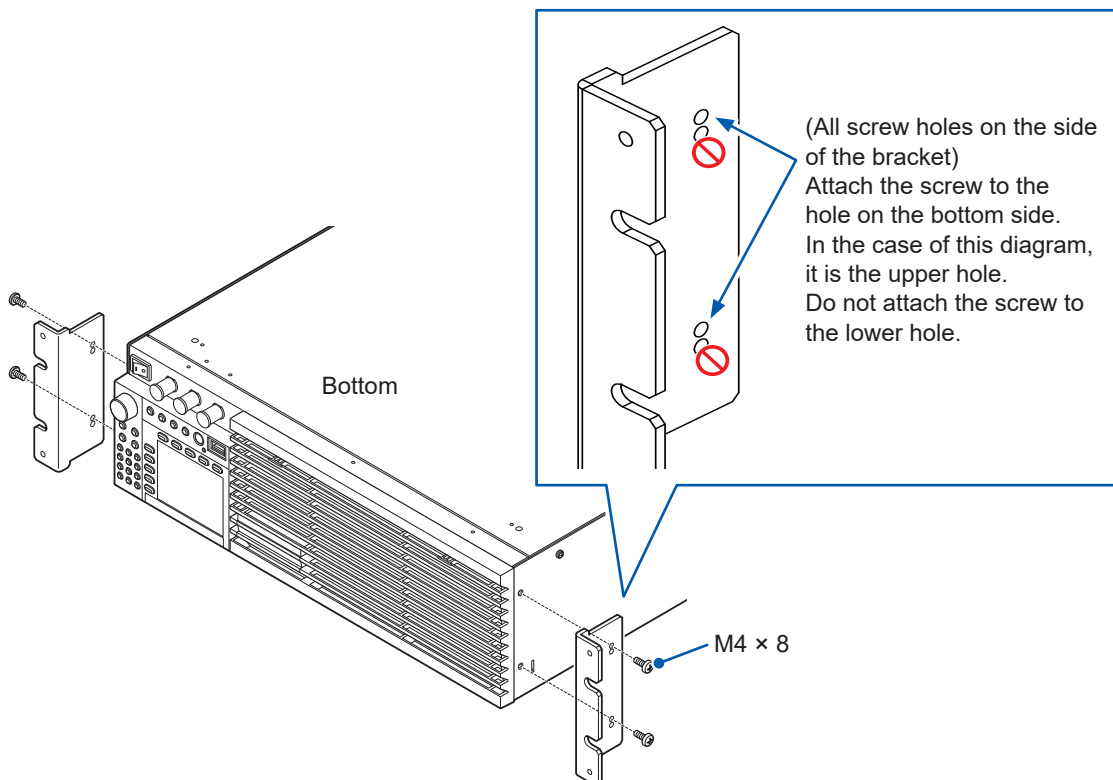

13.2 Embedding Devices into the Rack Cabinet

Rack cabinet configuration

Z5411 Rack Cabinet Configuration

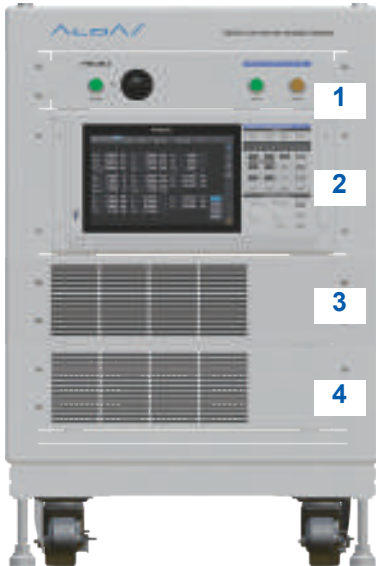

	Height	Configuration	
1	2U	EA5901	Control Module
2	5U	EA5302-0x	Sense Module
3	3U	Z7048	Blank panel
4	3U	EA5502 Z7048	Source Module Blank panel

Z5412 Rack Cabinet Configuration

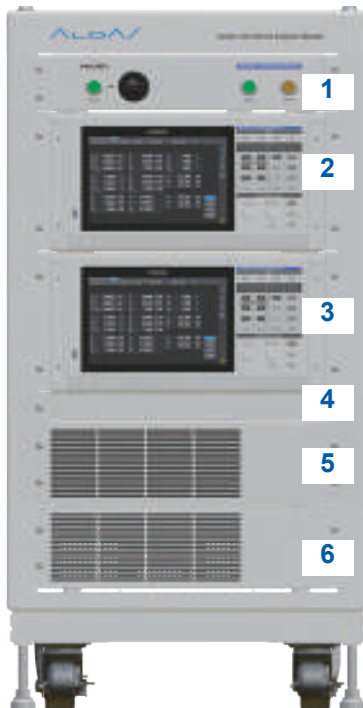

	Height	Configuration	
1	2U	EA5901	Control Module
2	5U	EA5302-0x	First Sense Module unit
3	5U	EA5302-0x	Second Sense Module unit
4	1U	Z7047	Blank panel
5	3U	EA5502 Z7048	Second Source Module unit Blank panel
6	3U	EA5502 Z7048	First Source Module unit (When two modules are used, this is the primary module) Blank panel

Z5413 Rack Cabinet Configuration

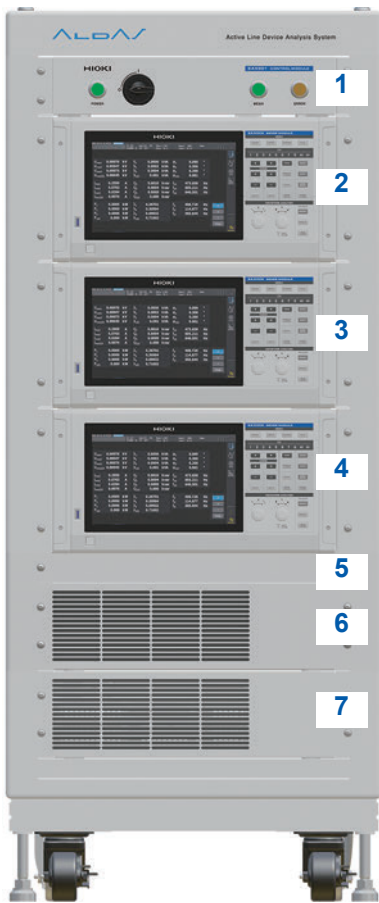

	Height	Configuration	
1	2U	EA5901	Control Module
2	5U	EA5302-0x	First Sense Module unit
3	5U	EA5302-0x	Second Sense Module unit
4	5U	EA5302-0x	Third Sense Module unit
5	1U	Z7047	Blank panel
6	3U	EA5502 Z7048	Second Source Module unit Blank panel
7	3U	EA5502	First Source Module unit (When two modules are used, this is the primary module)
		Z7048	Blank panel

Embedding devices into the rack cabinet

CAUTION



- When embedding each device into the rack cabinet, work with at least one other person to hold the device.
- Follow your company's safety guidelines, such as using anti-slip gloves and safety boots.

Failure to follow this guidance could cause bodily injury.

IMPORTANT

- The Z5411, Z5412, and Z5413 rack cabinets are pre-wired with power cords, LAN cables, and Z7041 Connection Cables (BNC to D-sub 25).
Since the racks are already wired, please do not use the individual power cords or LAN cables supplied with each module. Instead, store them securely to prevent loss or mix-ups.
When there are any slots (modules) of the rack cabinet that are not to be used, the power cords or LAN cables for those slots will be left unconnected. However, there is no problem if you use the system as it is.
- Blank panels for the Source Module remain attached to the Z5411, Z5412, and Z5413 Rack Cabinets during shipping.
Before beginning work, remove the blank panel attached to the slot (module) to be used.

Items to prepare: Phillips screwdriver (No. 2)

- 1 Set the power switches of the EA5302 Sense Module and EA5502 Source Module to the ON position.**
For the power switch location of each module, see "1.2 Part Names and Functions" (p.24).
- 2 Insert each module and blank panel into the rack cabinet from the front side of the rack cabinet from the bottom slot in order, while aligning them with the relevant support angle of the rack cabinet.**
- 3 For EA5302 Sense Module and EA5901 Control Module:**
Attach each module to the rack cabinet using the decorative screws (at four locations for each module/blank panel).

For EA5502 Source Module:

Tighten the module together with the Z7048 Blank Panel using the supplied decorative screws (at four locations), and then attach the module to the rack cabinet.

Before attaching the modules, make sure that the power switch for the EA5502 is set to on.

- 4 Connect the power cord and LAN cable on the back of the rack cabinet for each module.**
For more information about how to connect the power cords and LAN cables, see "13.3 Connecting the Power Cords and LAN Cables" (p. 148).
- 5 Remove the protective plate attached to the EXT CONT connector for the Source Module designated as the primary module (lower module).**
Store the removed protective plate. Use the screws in the following steps.

6 Connect the Source Module control signal output terminal (BNC) of the Control Module to the EXT CONT connector (Dsub25) of the Source Module using the Z7041 Connection Cable (BNC - Dsub25).

If no Source Cable is connected to the Source Module, connect one before beginning this work (see “2.5 Connecting the Source Cables” (p.43)).

When connecting the Z7041 to the EXT CONT connector, secure it with the screws used for attaching the protective plate.

Z7041 Connection Cable
(Pre-wired in the rack cabinet)

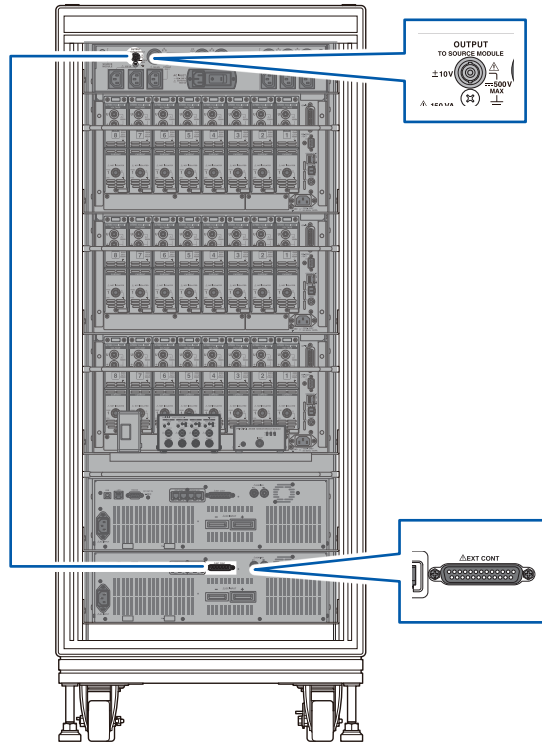

7 (Perform the steps from **7** to **9** when operating two Source Modules in parallel.)
Remove the protective cover attached to the PARALLEL connector of each Source Module.

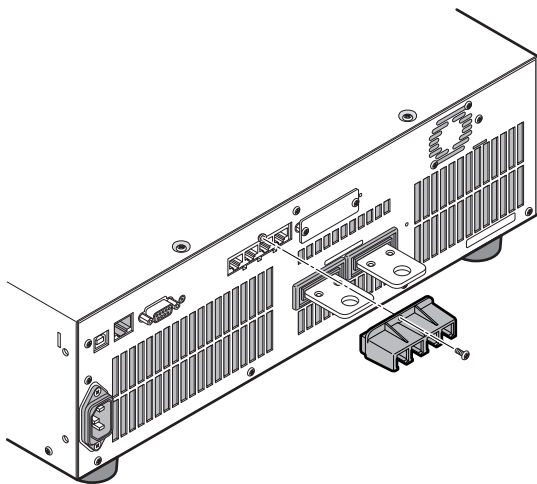

8 Connect each Source Module using the Z7042 Connection Cable.

Connect the primary module (lower module) to “OUT” of the PARALLEL connector, and the secondary module (upper module) to “IN”.

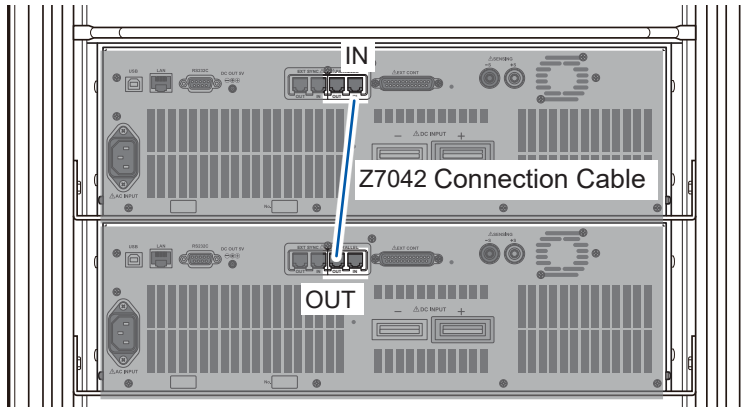
**9 Attach the protective cover to the PARALLEL connector of each Source Module.**

Attach the protective covers removed in step **7** above.

10 (Perform steps **10 and **11** when the optional CT9557 Sensor Unit and Z5405 Sensor Branch Module are used.)**
Connect the various wiring lines and perform settings for the CT9557 Sensor Unit and Z5405 Sensor Branch Module.

Connect the power cord and DC plug for the AC adapter (accessory) to the CT9557, and then turn on the power switch for the CT9557.

For more information about how to use the sensor branch module, see “10 Sensor Branch Module” (p.106).

For more information about how to use the CT9557 Sensor Unit, see the instruction manual for the CT9557. See “Information on download site” (p.7)

11 Install the CT9557 (including the AC adapter) and Z5405 in the storage shelf on the back of the rack cabinet as shown in the picture below, and then fix them to the storage shelf using the supplied belt.

Fixing example



13.3 Connecting the Power Cords and LAN Cables

Connecting the power cords

DANGER



- **Use only the specified power cord to provide power to the modules.**
Using a power cord other than the specified part will cause a fire, resulting in serious bodily injury.

WARNING



- **Connect the power cord to a 3-prong grounded-type (2-pole) power outlet.**
Connecting the power cord to an ungrounded power outlet could result in electric shock.

CAUTION



- **Do not use a power supply that generates a rectangular or pseudo-sine wave, such as an uninterruptible power supply (UPS) or DC/AC inverter, to supply power to the product.**
Doing so could damage the products, resulting in bodily injury.



- **Before connecting the power cord to the outlet, verify that the your supply voltage falls within the supply voltage range noted on the AC inlet of the module.**
Supplying a voltage that falls outside the specified range to the modules could damage them, causing bodily injury.
- **Ground the ground terminals of the system and the equipment to be connected at a same location.**
Connecting the cable when there is a difference in ground potentials between them could cause damage or malfunction.

- 1 Turn off the power (main breaker) to the Control Module.**
- 2 Connect the power cord to each device as shown in the following connection diagram.**
The power cords for the Sense Module and Source Module are pre-wired within the rack cabinet duct. Please use these cords. Do not use the power cords included with the product. Store them for replacement or as spares.
- 3 Verify that the main power supply voltage falls within the rated range (AC 100 V to 240 V) and connect the included power cord (for the main power supply) to the Control Module's power inlet.**
- 4 Connect the power cord's plug to main power supply outlet.**

Power cord connection diagram (In the case of the Z5413 Rack Cabinet configuration)

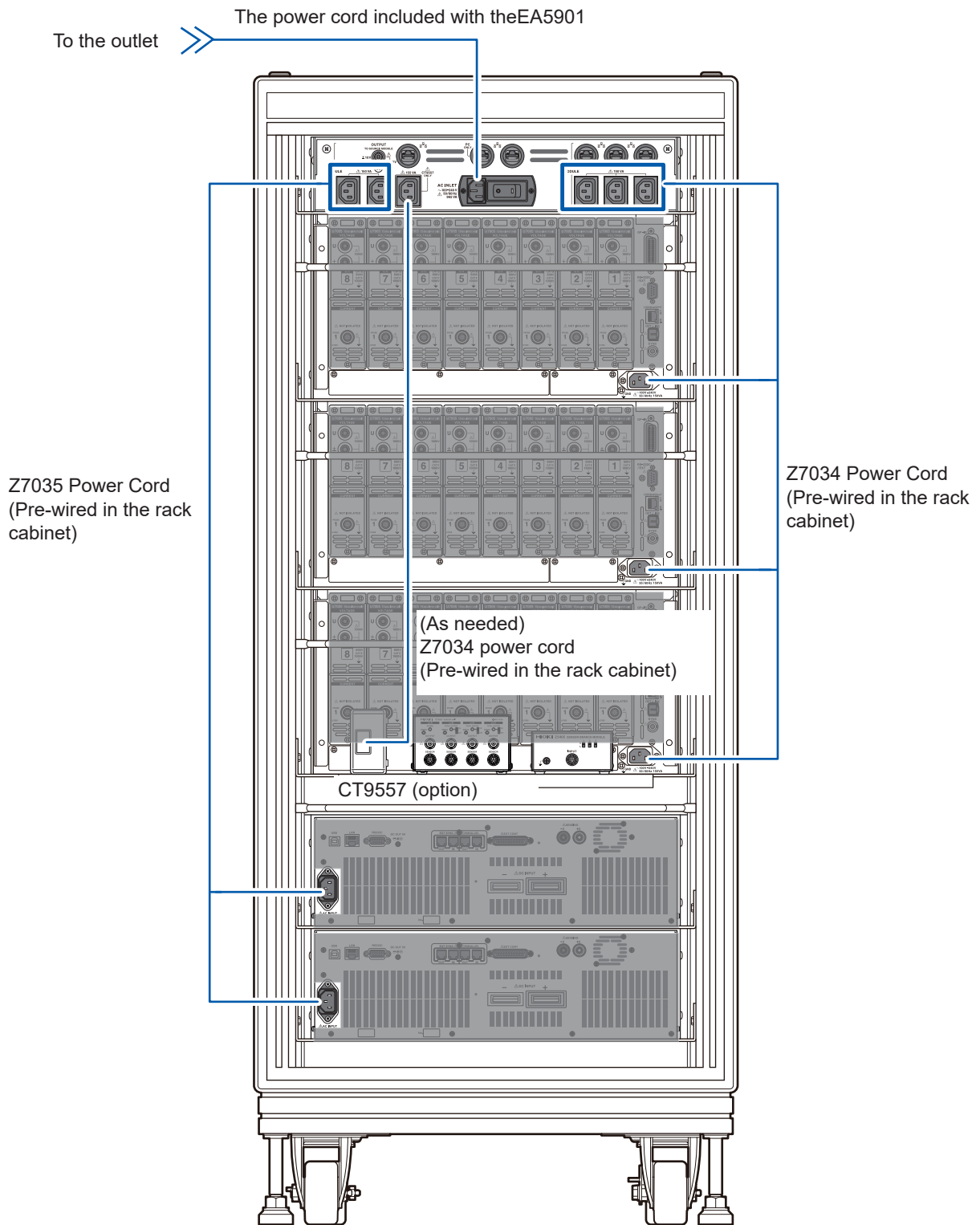

Connecting the LAN cables

Connect LAN cables to the RJ-45 (Gigabit Ethernet) connectors of the modules.

CAUTION



- **Do not unplug LAN cables while measurement is in progress.**

Doing so could damage the modules and the computer.

- **If routing LAN cables that are longer than 30 m, attach LAN surge protectors or other suitable protective devices.**

Failure to do so could cause damage to the system due to increased susceptibility to the effects of induced lightning.



- **Turn off the products and computer before connecting or disconnecting cables.**

Failure to do so could damage the modules and the computer being connected or cause them to malfunction.

IMPORTANT

Use a Shielded Twisted-Pair (STP) cable of category 6A or above for a LAN cable.

1 Turn off the power (main breaker) to the Control Module.

2 Connect a LAN cable to each device as shown in the following connection diagram.

Use the LAN cables for the Sense Module and Source Module that have been already routed inside the duct of the rack cabinet. Store the LAN cables included in the package of the product as replacement or spare parts, as they are not used at this point.

LAN cable connection diagram (when two or more rack cabinets are used)

From the second rack cabinet onward

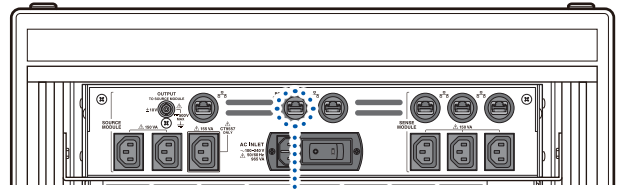

The connection with the Sense Module is the same as for the first unit.

First rack cabinet

To PC

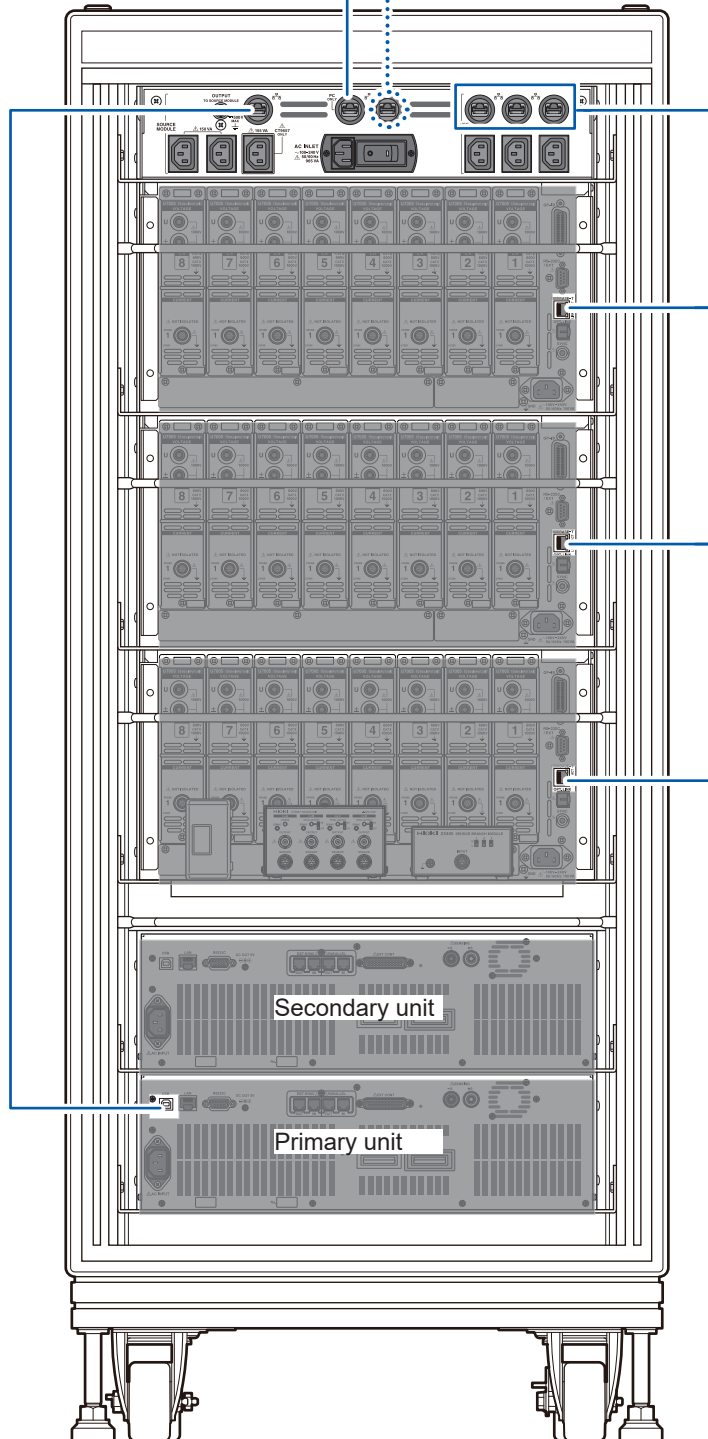

Z7039 LAN cable
(Pre-wired in the rack cabinet)

Z7038 LAN cable
(Pre-wired in the rack cabinet)

Connect to the primary unit.

14

Moving and Installing the Rack Cabinet

14.1 Moving the Rack Cabinet

⚠ WARNING



- When moving the rack cabinet, work with at least one other person standing on the left and right sides to push the rack cabinet.
- Do not move the rack cabinet toward the front or side (always push the rack from the front to the back).
- Follow your company's safety guidelines, such as using anti-slip gloves and safety boots.

Otherwise the system could tip over or fall, resulting in bodily injury. To ensure safety, always work with at least one other person.

⚠ CAUTION



- Do not subject the products to vibration or mechanical shock while transporting or handling the rack cabinet.

Failure to follow this guidance could damage the products.

- 1** Turn the hexagon nut of each floor leveler (four locations in total) to raise the floor leveler so that it does not contact the floor or any gaps/steps.

You can rotate the floor leveler by inserting a screwdriver with $\phi 6$ mm shaft diameter or less into the $\phi 6.5$ mm hole in the hexagon nut.

- 2** Unlock the lockable casters (at two locations).

- 3** When moving the rack cabinet, work with at least one other person standing on the left and right sides of the rack. Push the rack cabinet from the front to the back to move it.

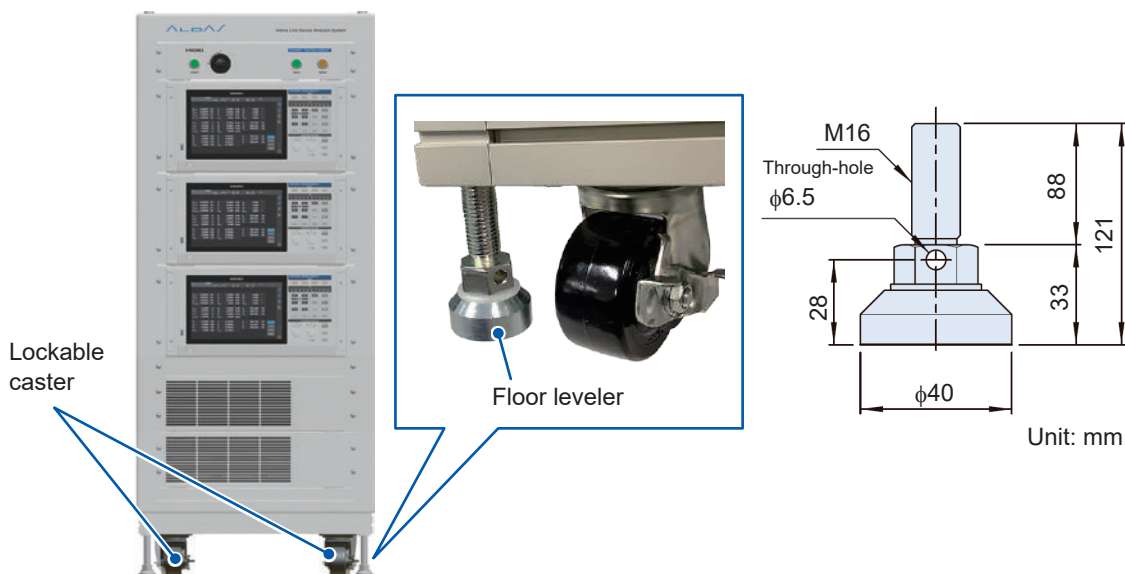

14.2 Installing the Rack Cabinet

WARNING

- To ensure safety, always work with at least one other person when installing the rack cabinet.
- Be sure to take proper measures to prevent the rack from tipping over, such as using anchor brackets.
Otherwise the system could tip over or fall, resulting in bodily injury.



Item to prepare: Z7050 Anchor Brackets

- 1** Lock the lockable casters (at two locations).
- 2** Turn the hexagon nut of each floor leveler (four locations in total) to lower the floor leveler until it contacts the floor.
- 3** Attach the Z7050 Anchor Brackets to each floor leveler and secure it with the anchor.
Request a contractor with specialized knowledge to perform the anchor attachment.

Example of attaching anchor brackets

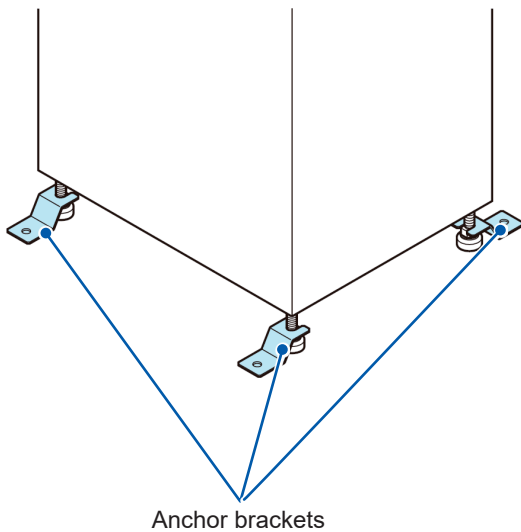

Dimensional drawing of Z7050 Anchor Brackets

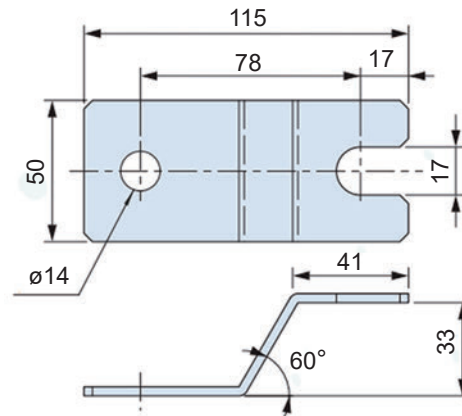

Unit: mm

15 Appendix

Impedance measurement during DC operation

The system measures the impedance of the measurement target (electrolysis cell) during DC operation with a DC power supply by using the four-terminal method to measure the voltage and measuring current using a current sensor. The impedance measurement procedure and principles are described below.

Measurement procedure

- 1 AC current superposition:** The Source Module draws in the load current I_{load} to generate the AC signal current I_{sig} which is use for superposition on the measurement target.
- 2 Voltage measurement:** The voltage drop V_{sig} due to the impedance of the measurement target is measured by the Sense Module.
- 3 Current measurement:** The AC current I_{sig} flowing to the measurement target is measured by the current sensor.
- 4 Impedance calculation:** The impedance is calculated from the measured voltage V_{sig} and current I_{sig} and the phase difference θ using the following formulas:

Real part: $R = V_{sig} / I_{sig} * \cos\theta$

Imaginary part: $X = V_{sig} / I_{sig} * \sin\theta$

Superposing the AC signal onto the measurement target

The system superposes a sine wave signal on the DC power supply line of the operating measurement target. The Source Module draws in part of the electrolysis cell current I_{dc} and adds the AC current signal, I_{sig} to the current flowing to the measurement target by changing the load current I_{load} flowing to the Source Module over time. In other words, the current flowing to the measurement target never exceeds the supplied DC current value, even during impedance measurement with signal superposition.

Fig. 1 illustrates the AC current signal, I_{sig} when added to the measurement target DC power supply value. Note that during signal superposition for impedance measurement, the average value of the current flowing through the measurement target will be less than the current during nonmeasurement (without signal superposition).

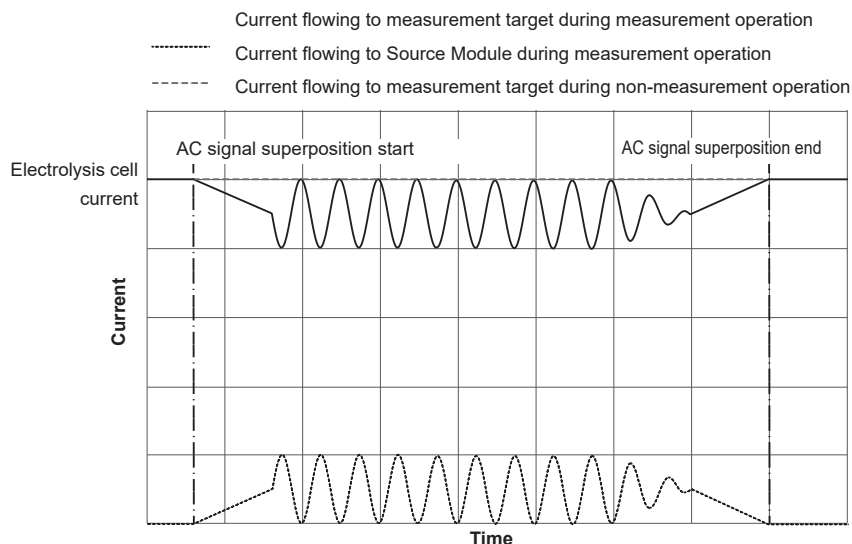

Fig. 1 Signal superposition by the Source Module

Voltage measurement using the four-terminal method

In general, electrolysis cells have low resistance, so this system uses a four-terminal method to reduce errors caused by the wiring resistance of the Sense Cable (see Fig. 2).

During impedance measurement, the AC component I_{sig} is added to the measurement target DC power line by the system's Source Module. At this time, the Sense Module detects the voltage drop V_{sig} caused by the impedance of the measurement target. Due to the high input impedance of the Sense Module's voltage detection circuit, there is no voltage drop across the Sense Cable's wiring resistor R_2 or contact resistor R_3 , since there are no current flows through them. In this way, the four-terminal method measurement eliminates the unwanted effects of the wiring resistance and contact resistance of the Sense Cable.

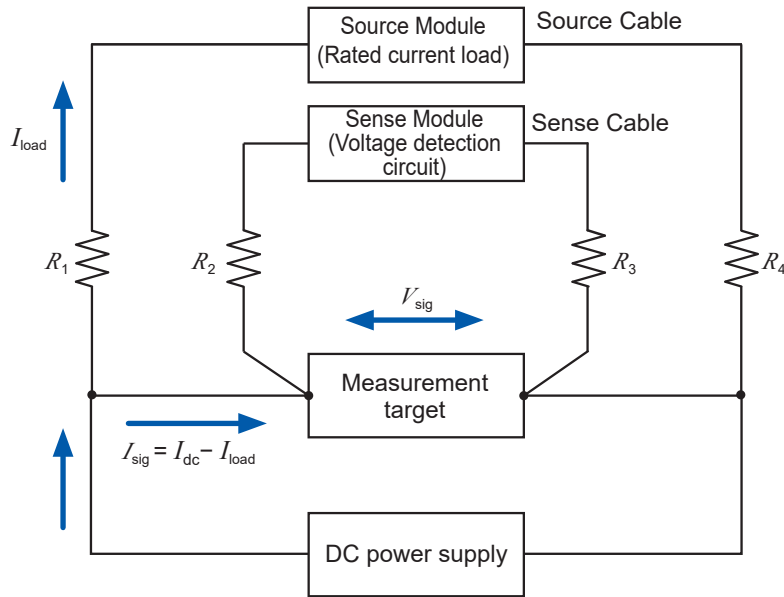

Fig. 2 Measurement using the four-terminal method

Measuring current flowing to the measurement target (electrolysis cell)

When performing impedance measurements on a system operating in a closed circuit with a DC power supply, such as an electrolysis cell, the measuring system sees the measurement target as connected in parallel with the DC power supply.

Therefore, in a typical impedance measuring instrument, the measurement current I_{AC0} from the measurement signal source is divided into the current flowing to the measurement target, I_{AC1} , and the current flowing to the DC power supply, I_{AC2} . Since the impedance calculation relies on the instrument's applied measurement signal current I_{AC0} , the measured impedance result includes both the measurement target and the DC power supply, making it impossible to measure the impedance of the measurement target alone (Fig. 3).

By contrast, the system measures current with a current sensor, allowing it to measure just the AC component I_{sig} flowing to the measurement target and thereby to measure the impedance of the measurement target alone as long as the current sensor is attached to an appropriate path (a path between the Source Cable contact and the measurement target) (Fig. 4).

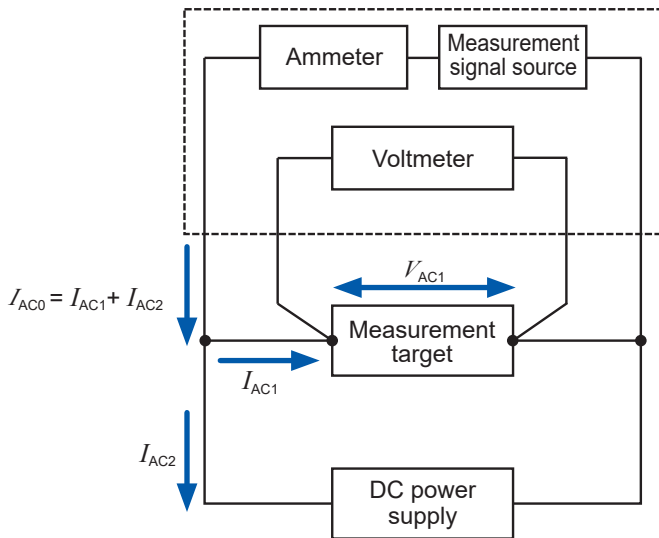

Fig. 3 When using a typical impedance tester

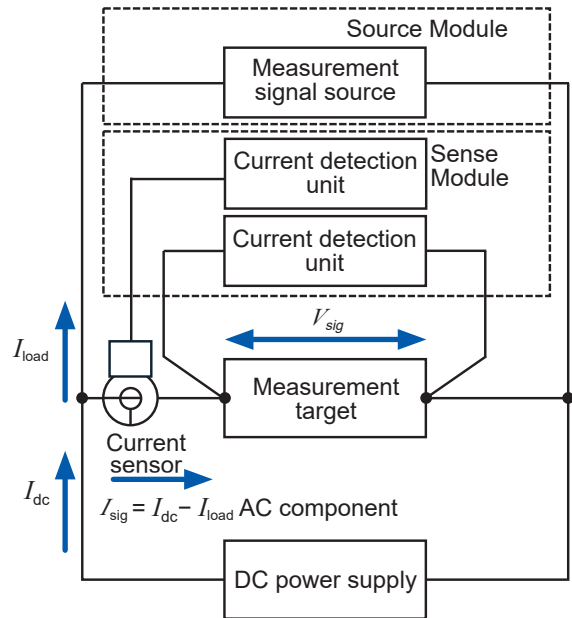

Fig. 4 When using this system

Methods for stabilizing measurement

Please twist the positive and negative wires of both the Sense and Source Cables as tightly as possible as shown in figure below.

(Example) L1101 Sense Cable



If the Source Cables cannot be twisted due to their wiring conditions, locate the cables as close as possible to each other.

Since the system measures extremely small impedance values using AC, it is susceptible to the effects of electromagnetic induction. The effects of electromagnetic induction occur when the Source-side loop (current superposition side) acts on the Sense-side loop (voltage detection side). The loop area size and the distance between the Sense-side and Source-side loops determine the amount of induced magnetic flux from the Source-side that overlapped the Sense-side loop. Therefore, in order to reduce the effects of electromagnetic induction, it is important to minimize the loop area and to place the Source and Sense Cables as far apart as possible. Specifically, twist the HIGH (positive) and LOW (negative) wires for both the Source and Sense Cable. If the Source Cable cannot be twisted, locate the HIGH and LOW wires of the Source Cable as close as possible to each other. The wire twist reduces the area of each loop and hence reduces the effects of electromagnetic induction during measurement.

Twisting the cables is also effective as a countermeasure against external inductive noise. Please twist both the Sense and Source Cables tightly and as close as possible to the measurement target.

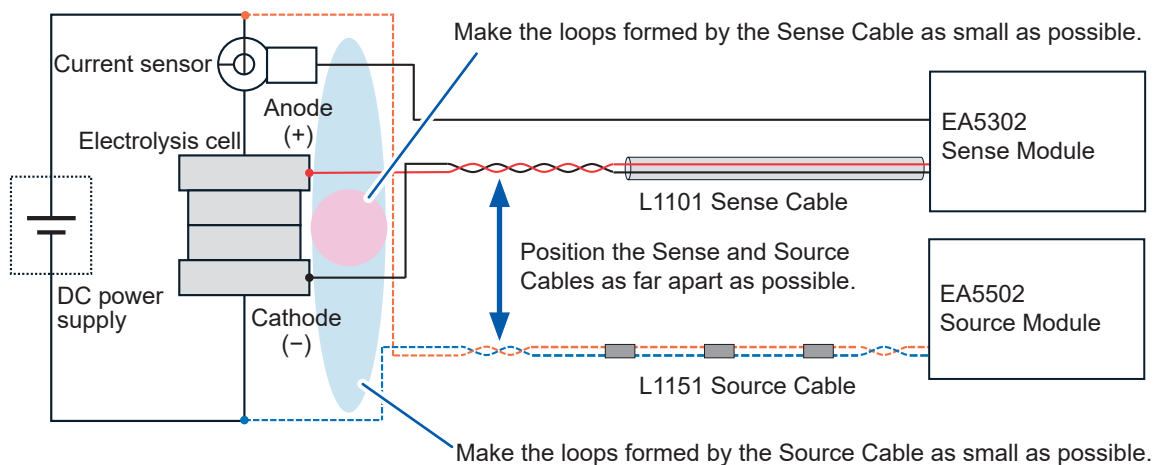

Fig. 5

16 License Information

EA5302 Sense Module

The EA5302 Sense Module contains software that requires the GNU General Public License, GNU Lesser General Public License, and some other licenses. The customer is granted the right to obtain, modify, or redistribute the source code of the software according to these licenses.

For more details, see the following website.

<https://www.hioki.com/global/support/oss>

Please refrain from making inquiries about the contents of the source code to Hioki.

EA5901 Control Module

The EA5901 Control Module uses the following open-source software.

Amazon FreeRTOS

Copyright (C) 2020 Amazon.com, Inc. or its affiliates. All Rights Reserved.

Permission is hereby granted, free of charge, to any person obtaining a copy of this software and associated documentation files (the "Software"), to deal in the Software without restriction, including without limitation the rights to use, copy, modify, merge, publish, distribute, sublicense, and/or sell copies of the Software, and to permit persons to whom the Software is furnished to do so, subject to the following conditions:

The above copyright notice and this permission notice shall be included in all copies or substantial portions of the Software.

THE SOFTWARE IS PROVIDED "AS IS", WITHOUT WARRANTY OF ANY KIND, EXPRESS OR IMPLIED, INCLUDING BUT NOT LIMITED TO THE WARRANTIES OF MERCHANTABILITY, FITNESS FOR A PARTICULAR PURPOSE AND NONINFRINGEMENT. IN NO EVENT SHALL THE AUTHORS OR COPYRIGHT HOLDERS BE LIABLE FOR ANY CLAIM, DAMAGES OR OTHER LIABILITY, WHETHER IN AN ACTION OF CONTRACT, TORT OR OTHERWISE, ARISING FROM, OUT OF OR IN CONNECTION WITH THE SOFTWARE OR THE USE OR OTHER DEALINGS IN THE SOFTWARE.

lwip

lwIP is licenced under the BSD license:

Copyright (c) 2001-2004 Swedish Institute of Computer Science.

All rights reserved.

Redistribution and use in source and binary forms, with or without modification, are permitted provided that the following conditions are met:

1. Redistributions of source code must retain the above copyright notice, this list of conditions and the following disclaimer.
2. Redistributions in binary form must reproduce the above copyright notice, this list of conditions and the following disclaimer in the documentation and/or other materials provided with the distribution.

3. The name of the author may not be used to endorse or promote products derived from this software without specific prior written permission.

THIS SOFTWARE IS PROVIDED BY THE AUTHOR "AS IS" AND ANY EXPRESS OR IMPLIED WARRANTIES, INCLUDING, BUT NOT LIMITED TO, THE IMPLIED WARRANTIES OF MERCHANTABILITY AND FITNESS FOR A PARTICULAR PURPOSE ARE DISCLAIMED. IN NO EVENT SHALL THE AUTHOR BE LIABLE FOR ANY DIRECT, INDIRECT, INCIDENTAL, SPECIAL, EXEMPLARY, OR CONSEQUENTIAL DAMAGES (INCLUDING, BUT NOT LIMITED TO, PROCUREMENT OF SUBSTITUTE GOODS OR SERVICES; LOSS OF USE, DATA, OR PROFITS; OR BUSINESS INTERRUPTION) HOWEVER CAUSED AND ON ANY THEORY OF LIABILITY, WHETHER IN CONTRACT, STRICT LIABILITY, OR TORT (INCLUDING NEGLIGENCE OR OTHERWISE) ARISING IN ANY WAY OUT OF THE USE OF THIS SOFTWARE, EVEN IF ADVISED OF THE POSSIBILITY OF SUCH DAMAGE

Index

0ADJ key 26

A

AbsZ_SenseModule1_Ch 100
ALDAS format 94, 100
ArgZ_SenseModule1_Ch 100
Auto Scale 86

C

Cell area size 60, 81
Cell name 81
Cleaning 131
Cole-Cole plots 23
CONFIG 76, 80
CurrentDensity 84
Current input 46
Current sensor 46
Current sensor settings 67

D

DATA 73
Data file 73, 85, 94
DataFiles 70
Data filter 77
Data format 99
Data table 63, 69, 74, 85
 |Z| [mΩ] 74
 Arg(Z) [deg] 74
 Date 74
 Elapsed Time [s] 74
 Frequency [Hz] 74
 Idc [A] 74
 Info 74
 Isig [Ap-p] 74
 No 74
 R [mΩ] 74
 Vdc [V] 74
 Vsig [Vp-p] 74
 X [mΩ] 74
Date 100
Default gateway 40, 41
Degaussing 50
Display legend 76
Disposal 137
DMAG 50

E

EIS Mode (Frequency Sweep) 61
ElapsedTime 100
Export I-V data 84

F

Fast 62, 64, 66
File path 84, 99
Formulas (Impedance calculation) 155
Frequency 63

G

Graph type 76

I

Idc 80, 82, 84
Idc_SenseModule1_Ch 100
I-Impedance Plot 80
Impedance graph 63, 69
Impedance real part (Highest frequency) 80, 82, 84
Impedance real part (Lowest frequency) 80, 82, 84
Input channels 27
InstrumentSettings 70
Invert Y-axis 76
IP address 39
I-Power Plot 80
IR-free Plot 80
IR-free Voltage 80
Isig_SenseModule1_Ch 100
I-V data 82
I-V graph 60, 69, 79, 80
I-V Plot 80

L

LAN 150
Logging interval 65, 66
Logging Mode (Fixed Frequency) 61

M

MAC address 25, 29
Main application window 69
MEASURE 71, 72, 90, 91, 92, 93
MeasuredFrequency_SenseModule1_Ch 100
Measurement project 56
MeasurementSettings 70, 92
Medium 62, 64, 66
Menu bar 62, 64, 66
Multi-plot format 94

N

Nyquist plots 23

O

Option settings..... 67

P

Plot Highlight 86
 Plot mode 76, 80
 Line 76, 80
 Line&Point..... 76, 80
 Point..... 76, 80
 Power 80
 Power key..... 26
 Power supply inlet 27
 Probe1 terminal 27

R

Relay cable..... 52
 Repair..... 129
 Reset Axes 86
 Rhf..... 80, 82, 84
 RJ-45 connector 27
 Rlf 80, 82, 84
 Rohm..... 60, 80, 81
 R_SenseModule1_Ch 100

S

Sense Cable 45
 Sense Module..... 26
 SetFrequency 100
 Side menu 62, 64, 66, 69
 Signal frequency..... 64
 Single cell 51
 Slow..... 62, 64, 66
 Snap Shot..... 86
 Source Cable..... 43
 Source Module 28
 Stack..... 52
 Subnet mask..... 40, 41
 Sweep..... 61

T

Tab list 62, 64, 66, 69
 Target information..... 73, 85
 Total measurement time 65, 66

U

USB dongle key..... 55

V

Vdc 80, 82, 84
 Vdc_SenseModule1_Ch..... 100
 Voltage input 45
 Voltage input terminals 27
 Voltage range 67
 Voltage sensor settings 67
 Vsig_SenseModule1_Ch..... 100

X

X-axis item..... 80
 X-axis scale 80
 X-axis unit..... 76
 X_SenseModule1_Ch..... 100

Y

Y-axis item 76
 Y-axis unit 76

Z

Zero adjustment..... 50
 ZView format 94

Warranty Certificate

HIOKI

Model	Serial number	Warranty period One (1) year from date of purchase (___ / ___)
-------	---------------	---------------------------------------------------------------------

Customer name: _____

Customer address: _____

Important

- Please retain this warranty certificate. Duplicates cannot be reissued.
- Complete the certificate with the model number, serial number, and date of purchase, along with your name and address. The personal information you provide on this form will only be used to provide repair service and information about Hioki products and services.

This document certifies that the product has been inspected and verified to conform to Hioki's standards.

Please contact the place of purchase in the event of a malfunction and provide this document, in which case Hioki will repair or replace the product subject to the warranty terms described below.

Warranty terms

1. The product is guaranteed to operate properly during the warranty period (one [1] year from the date of purchase).
If the date of purchase is unknown, the warranty period is defined as one (1) year from the date (month and year) of manufacture (as indicated by the first four digits of the serial number in YYMM format).
2. If the product came with an AC adapter, the adapter is warranted for one (1) year from the date of purchase.
3. The accuracy of measured values and other data generated by the product is guaranteed as described in the product specifications.
4. In the event that the product or AC adapter malfunctions during its respective warranty period due to a defect of workmanship or materials, Hioki will repair or replace the product or AC adapter free of charge.
5. The following malfunctions and issues are not covered by the warranty and as such are not subject to free repair or replacement:
 - 1. Malfunctions or damage of consumables, parts with a defined service life, etc.
 - 2. Malfunctions or damage of connectors, cables, etc.
 - 3. Malfunctions or damage caused by shipment, dropping, relocation, etc., after purchase of the product
 - 4. Malfunctions or damage caused by inappropriate handling that violates information found in the instruction manual or on precautionary labeling on the product itself
 - 5. Malfunctions or damage caused by a failure to perform maintenance or inspections as required by law or recommended in the instruction manual
 - 6. Malfunctions or damage caused by fire, storms or flooding, earthquakes, lightning, power anomalies (involving voltage, frequency, etc.), war or unrest, contamination with radiation, or other acts of God
 - 7. Damage that is limited to the product's appearance (cosmetic blemishes, deformation of enclosure shape, fading of color, etc.)
 - 8. Other malfunctions or damage for which Hioki is not responsible
 - 9. After disassembly, such as opening the product, has been performed by the customer without permission by Hioki
6. The warranty will be considered invalidated in the following circumstances, in which case Hioki will be unable to perform service such as repair or calibration:
 - 1. If the product has been repaired or modified by a company, entity, or individual other than Hioki
 - 2. If the product has been embedded in another piece of equipment for use in a special application (aerospace, nuclear power, medical use, vehicle control, etc.) without Hioki's having received prior notice
7. If you experience a loss caused by use of the product and Hioki determines that it is responsible for the underlying issue, Hioki will provide compensation in an amount not to exceed the purchase price, with the following exceptions:
 - 1. Secondary damage arising from damage to a measured device or component that was caused by use of the product
 - 2. Damage arising from measurement results provided by the product
 - 3. Damage to a device other than the product that was sustained when connecting the device to the product (including via network connections)
8. Hioki reserves the right to decline to perform repair, calibration, or other service for products for which a certain amount of time has passed since their manufacture, products whose parts have been discontinued, and products that cannot be repaired due to unforeseen circumstances.

HIOKI E. E. CORPORATION

25-10 EN-1

HIOKI
www.hioki.com/



**All regional
contact
information**

HIOKI E.E. CORPORATION
81 Koizumi, Ueda, Nagano 386-1192 Japan

2402 EN

Edited and published by HIOKI E.E. CORPORATION

Printed in Japan

- Contents subject to change without notice.
- This document contains copyrighted content.
- It is prohibited to copy, reproduce, or modify the content of this document without permission.
- Company names, product names, etc. mentioned in this document are trademarks or registered trademarks of their respective companies.

Europe only

- EU declaration of conformity can be downloaded from our website.
- Contact in Europe: **HIOKI EUROPE GmbH**
Helfmann-Park 2, 65760 Eschborn, Germany hioki@hioki.eu